



# RT200i/RT230i BARCODE PRINTER USER MANUAL



# CONTENTS

<b>1</b>	<b>Barcode Printer</b>	<b>001</b>
1.1	Box Content	001
1.2	Getting to Know Your Printer	002
<b>2</b>	<b>Printer Setup</b>	<b>005</b>
2.1	Open the Printer	005
2.2	Loading the Ribbon	006
2.3	Loading the Label Roll Module	010
2.4	Connecting the Printer to the Host Computer	013
2.5	Installing Printer Driver and QLabel with Super Wizard CD	015
<b>3</b>	<b>Setting and Control for Operation Panel</b>	<b>020</b>
3.1	Operation Panel	020
3.2	LCD Interface Introduction	021
3.3	LCD Interface Function	026
3.4	Label Calibration and Self Test	030
3.5	Error Alerts	032
3.6	USB Host	034
3.7	Dump Mode Begin	
<b>4</b>	<b>NetSetting for Ethernet</b>	<b>036</b>
4.1	Installing the NetSetting Software	036
4.2	The Interface of NetSetting	037
<b>5</b>	<b>Accessories</b>	<b>044</b>
5.1	Preparation Steps	044
5.2	Installing the Label Dispenser	046
5.3	Installing the Cutter	052
<b>6</b>	<b>Maintenance and Adjustment</b>	<b>056</b>
6.1	Cleaning the Print Head	056
6.2	Troubleshooting	057
	<b>Appendix</b>	
	Product Specifications	
	Interface	
	File Manipulation When Using USB Stick	

## FCC COMPLIANCE STATEMENT FOR AMERICAN USERS

This equipment has been tested and found to comply with the limits for a CLASS A digital device, pursuant to Part 15 Subpart B of the FCC Rules. These limits are designed to provide reasonable protection against harmful interference when the equipment is operated in a commercial environment. This equipment generates, uses, and can radiate radio frequency energy and, if not installed and used in accordance with the instructions, may cause harmful interference to radio communications.

Operation of this equipment in a residential area is likely to cause harmful interference in which case the user will be required to correct the interference at own expense.

## EMS AND EMI COMPLIANCE STATEMENT FOR EUROPEAN USERS

This equipment has been tested and passed with the requirements relating to electromagnetic compatibility based on the standards EN55032:2012/AC:2013 Class A, EN 61000-3-2:2014, EN 61000-3-3:2013 and EN55024:2010, IEC 61000-4-2:2008 series. The equipment also tested and passed in accordance with the European Standard EN55032 for the both Radiated and Conducted emissions limits.

## RT200i SERIES TO WHICH THIS DECLARATION RELATES IS IN CONFORMITY WITH THE FOLLOWING STANDARDS

IEC 60950-1:2005(2nd Edition)+Am 1:2009 Am 2:2013, GB4943.1-2011 GB9254-2008(Class A) GB17625.1-2013, EN55032:2012/AC:2013 Class A, EN 61000-3-2:2006/A2:2009, EN 61000-3-3:2008 and EN55024:2010, IEC 61000-4-2:2008 series, UL 60950-1, 2nd Edition, 2011-12-19, CSA C22.2 No. 60950-1-07, 2nd Edition, 2011-12, CFR 47, Part 15 Subpart B

### **WARNING**

This is a Class A product. In a domestic environment this product may cause radio interference in which case the user may be required to take adequate measures.

此为Class A产品，在生活环境中，该产品可能造成无线电干扰，在这种情况下，可能需要用户对其干扰采取切实可行的措施。

# SAFETY INSTRUCTIONS

Please read the following instructions carefully.

1. Keep the equipment away from humidity.
2. Before you connect the equipment to the power outlet, please check the voltage of the power source.
3. Make sure the printer is off before plugging the power connector into the power jack.
4. It is recommended that you connect the printer to a surge protector to prevent possible transient overvoltage damage.
5. Be careful not to get liquid on the equipment to avoid electrical shock.
6. For safety and warranty reasons, ONLY qualified service personnel should open the equipment.
7. Do not repair or adjust energized equipment under any circumstances.

## Caution

---

- \* Danger of explosion if battery is incorrectly replaced. Replace only with the equivalent type recommended by the manufacturer.
- \*\* Dispose of used batteries according to the manufacturer's instructions.
- \*\*\* Only use with designated power supply adapter model.
- \*\*\*\* Changes or modifications not expressly approved by the party responsible for compliance could void the user's authority to operate the equipment.



# 1 Barcode Printer

## 1.1 Box Content

Please check that all of the following items are included with your printer.

- RT200i/RT230i Barcode Printer

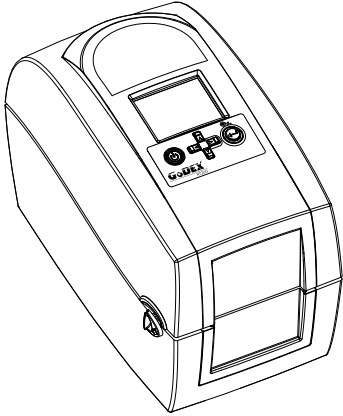

- Label Stock

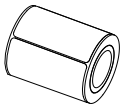

- Ribbon Module  
Empty Ribbon Core



Ribbon



- Power Adapter  
Power Cord

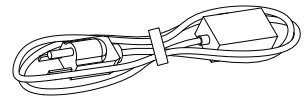

AC Adapter

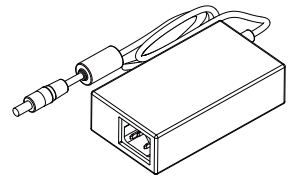

- USB Cable

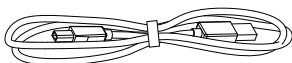

- CD  
Including GoLabel software  
and RT200i/RT230i user manual.



- RT200i/RT230i Quick Guide



\* Package content may vary per region.

# 1 Barcode Printer

## 1.2 Getting to Know Your Printer

### Device Overview

- Front View

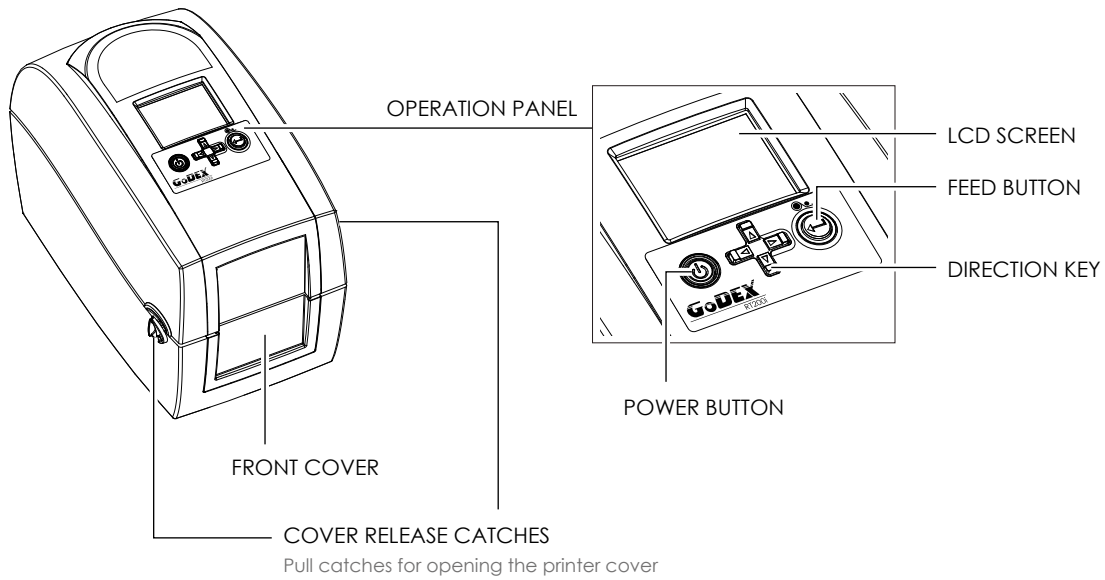

- Rear View

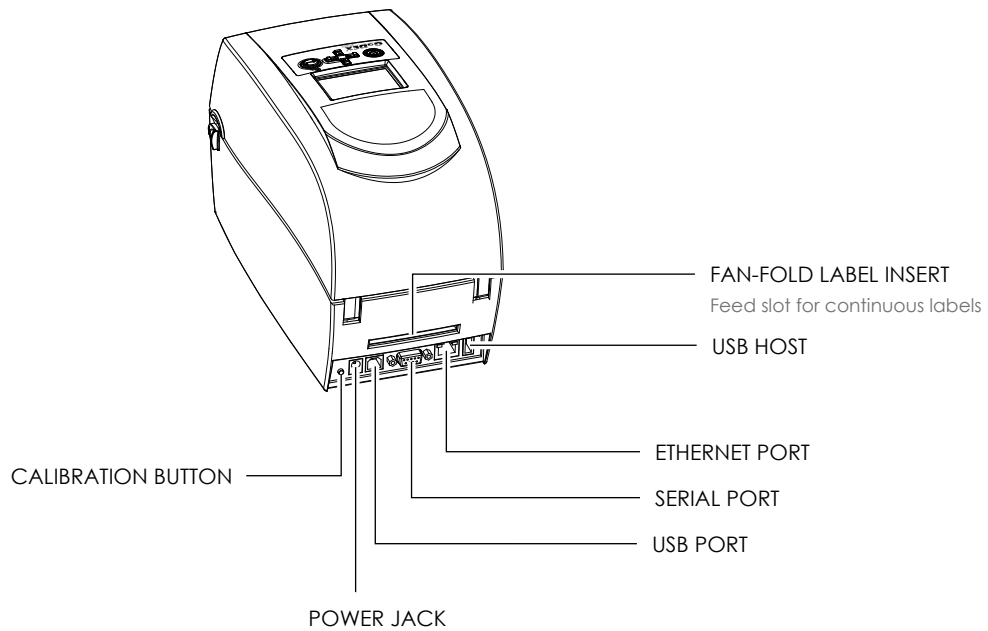

# 1 Barcode Printer

- Bottom View

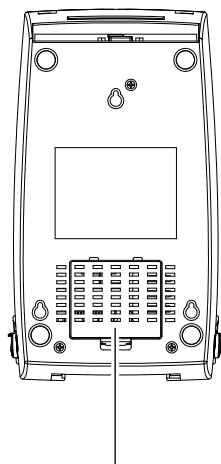

COVER OF THE MODULE CONNECTION JACKS

## Notice

---

- \* Cut-outs are not intended for wall-mount use.

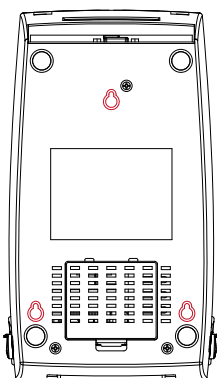

# 1 Barcode Printer

## The Internal View of Printer

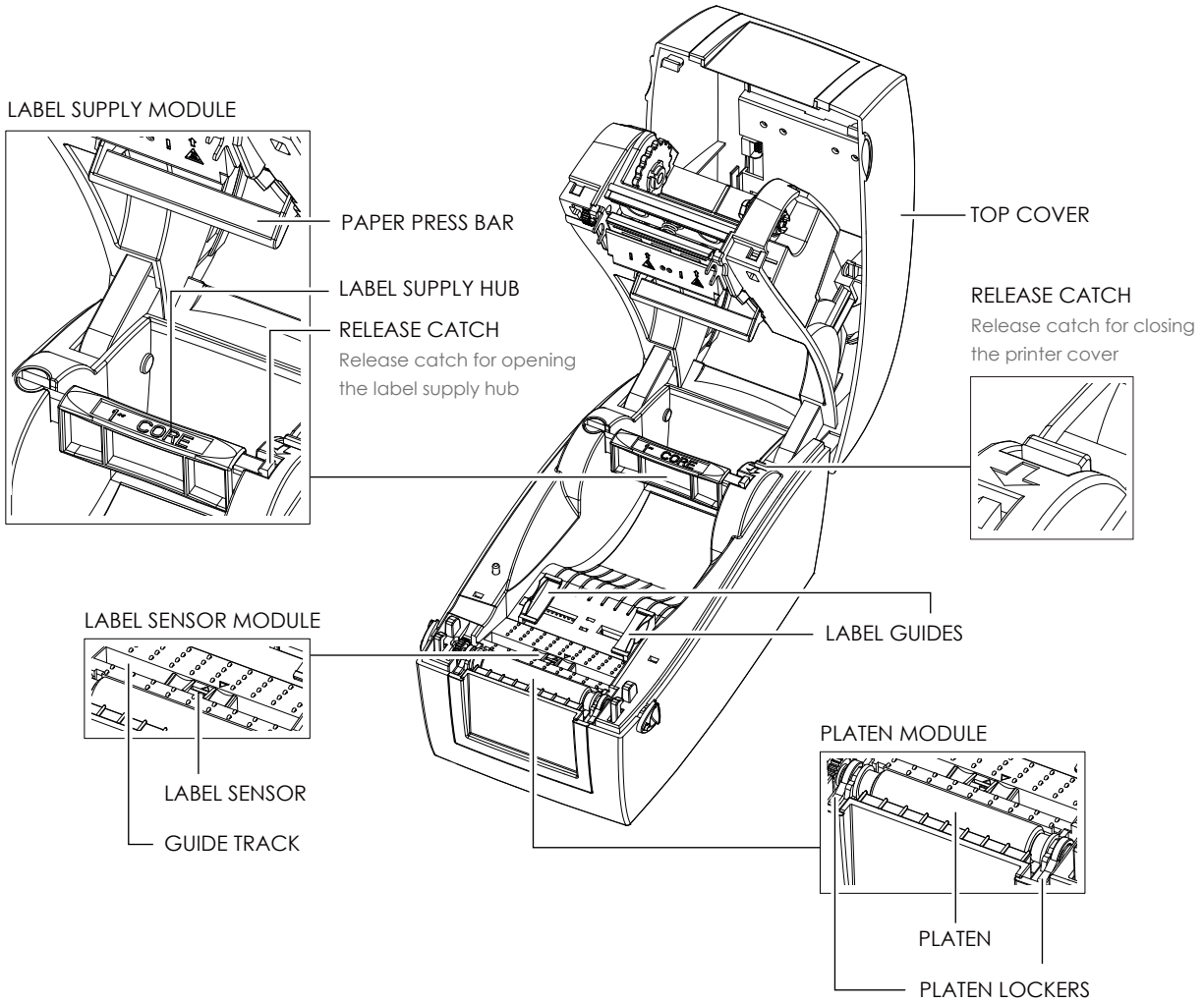

## The Printing Mechanism

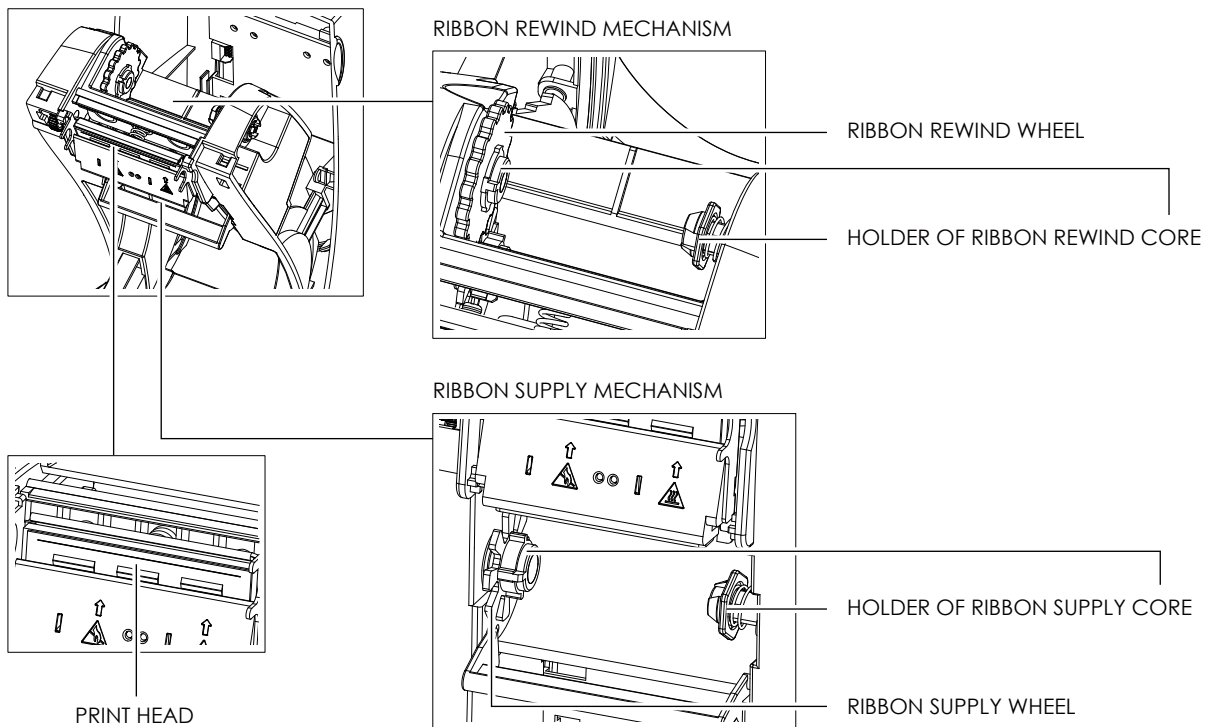

## 2 Printer Setup

### 2.1 Open the Printer

#### Open the Printer Cover and the Printing Mechanism

Place the printer on a flat surface. Open the printer cover by pulling the release catches on both sides of the printer and lift the cover.

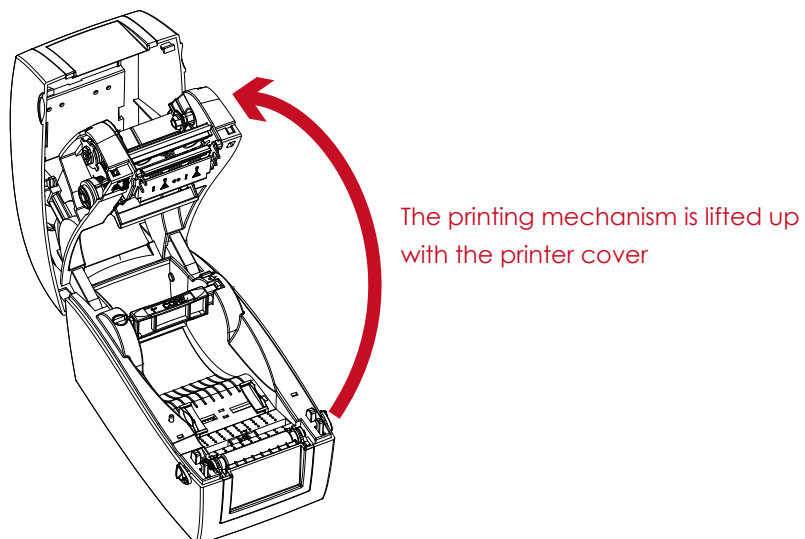
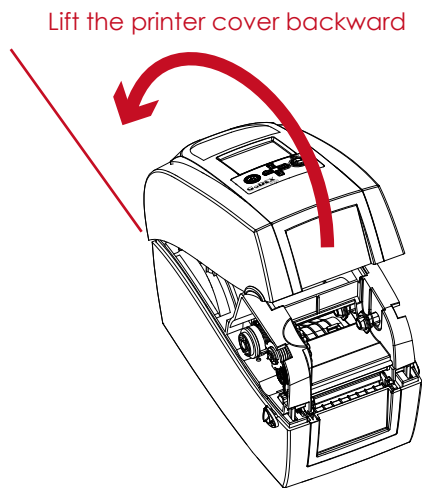
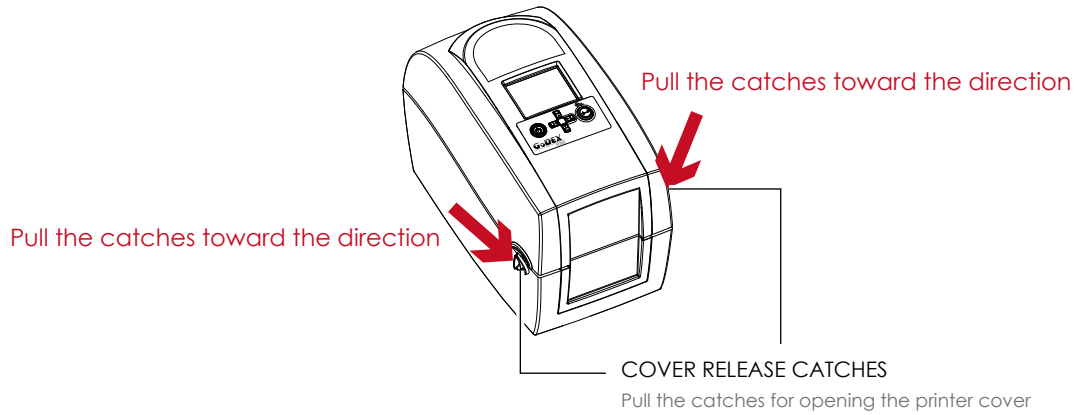

## 2 Printer Setup

### 2.2 Loading the Ribbon

#### A New Ribbon Module Installation

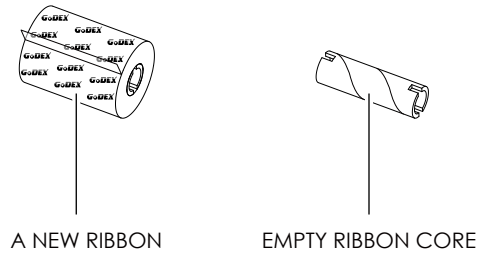

1. Attach the ribbon to the empty ribbon core with the adhesive strip at the end of the ribbon.

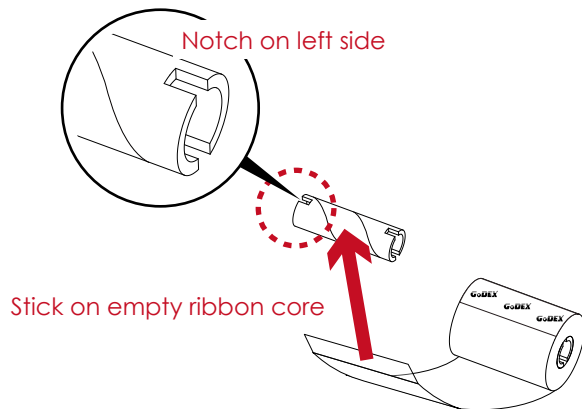

2. Wind the ribbon around the empty ribbon core for 2 to 3 circles.

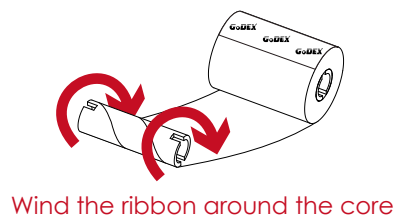

3. A ribbon module is assembled as below.

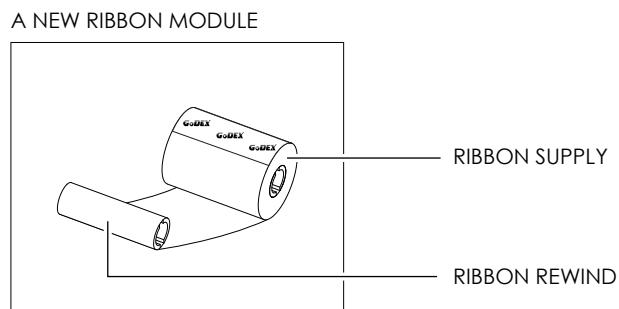

## 2 Printer Setup

### Load the Ribbon on the Printer For Ribbon Supply Module

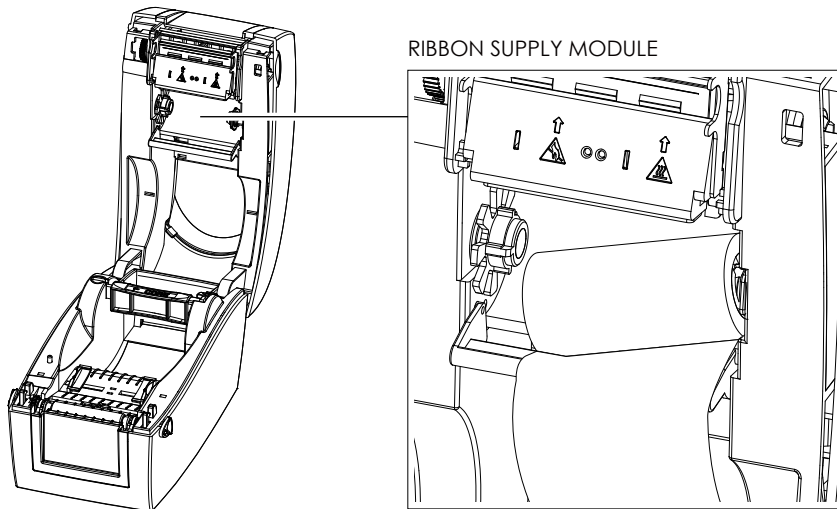

1. Place the right-hand side of ribbon first.

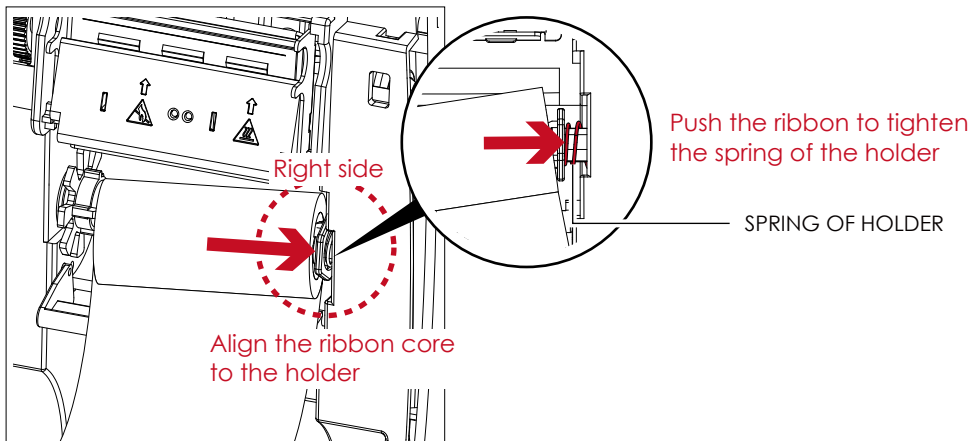

2. Then place the left-hand side of the ribbon.

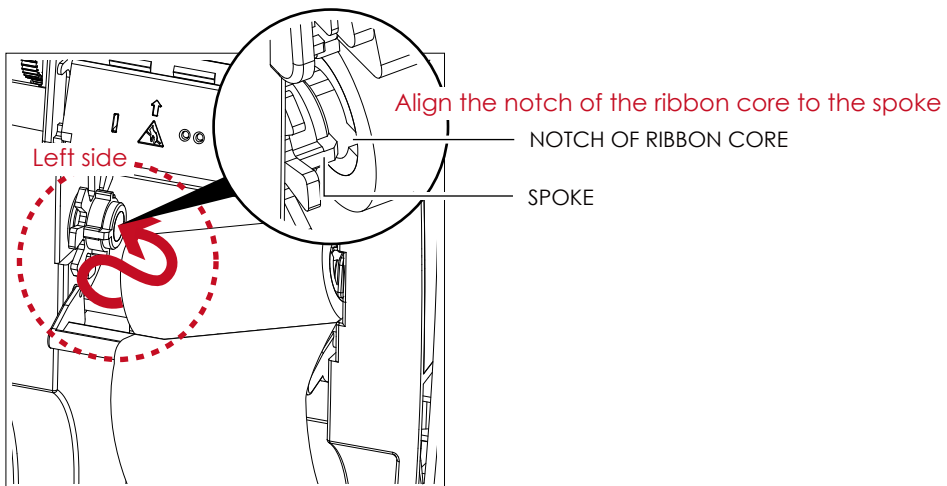

## 2 Printer Setup

3. The ribbon supply module loading is completed.

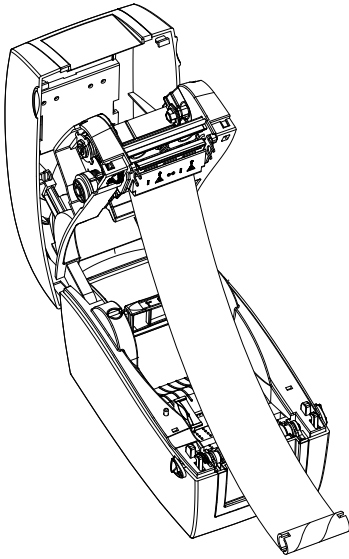

### Load the Ribbon on the Printer For Ribbon Rewind Module

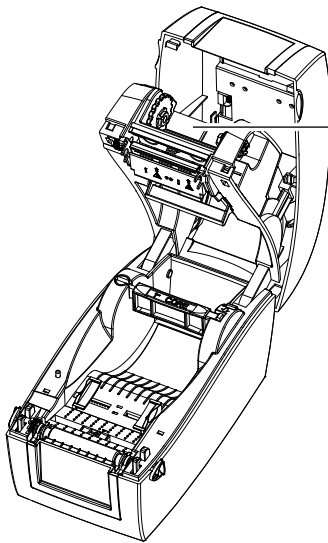

RIBBON REWIND MODULE

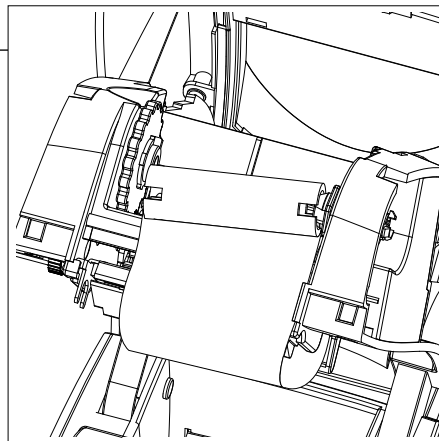

1. Pass the ribbon to round the print head.

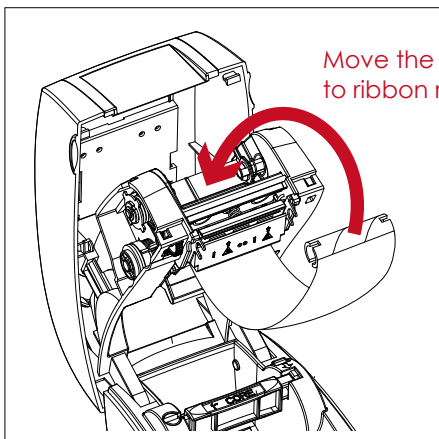

Move the empty ribbon core upward  
to ribbon rewind mechanism



## 2 Printer Setup

2. Place the right-hand side of empty ribbon core first.

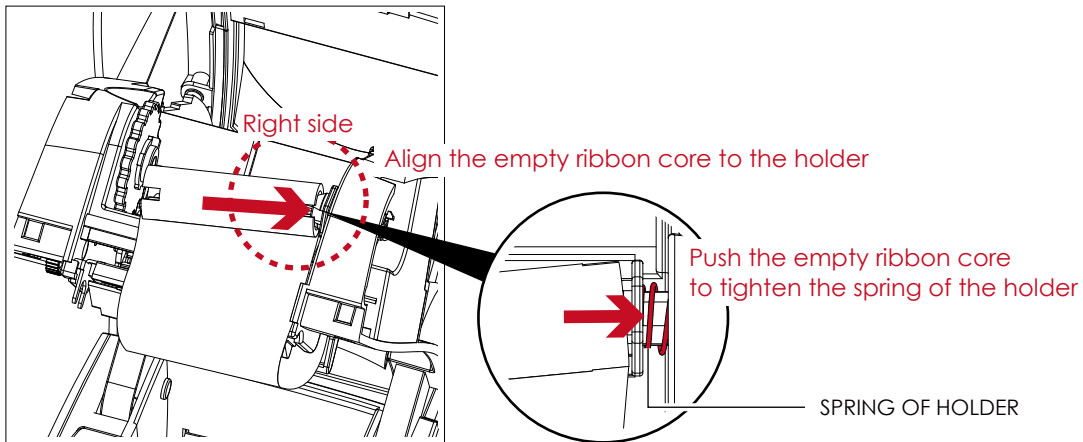

3. Then place the left-hand side of the empty ribbon core.  
Turn the ribbon wheel to align the notch of empty ribbon core to the spoke.

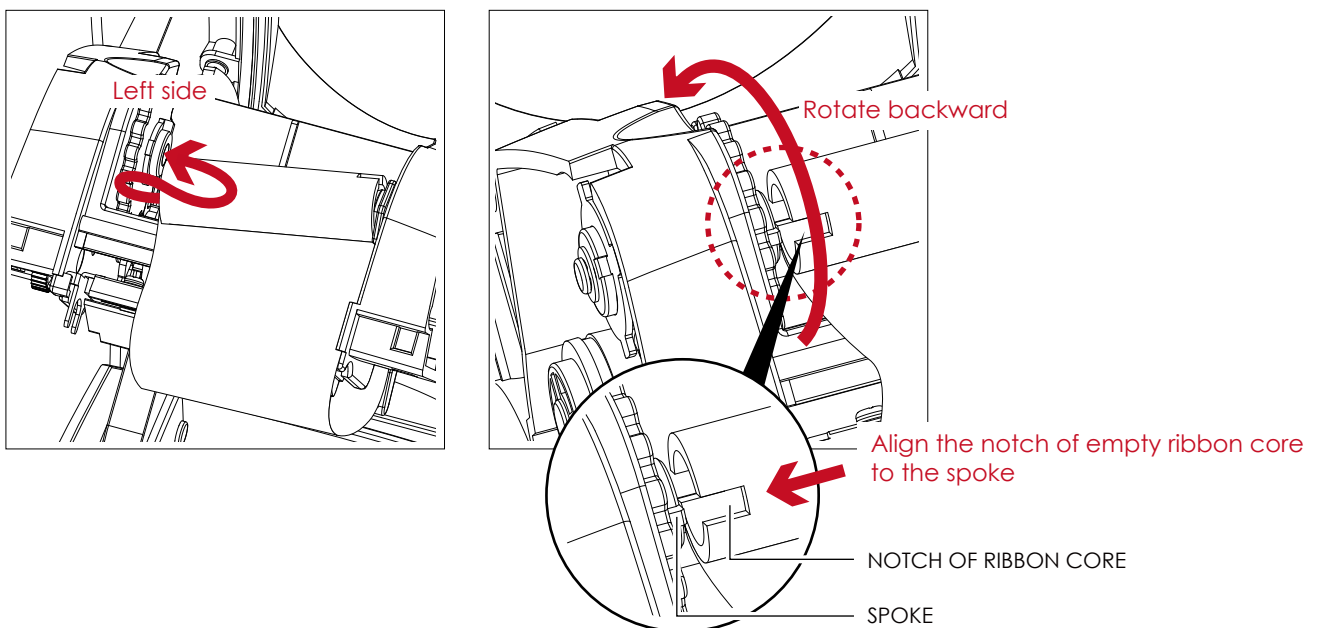

4. Turn the ribbon rewind wheel to tighten the ribbon until it has no wrinkles.  
The ribbon loading is completed once the ribbon supply module and ribbon rewind module are assembled correctly.

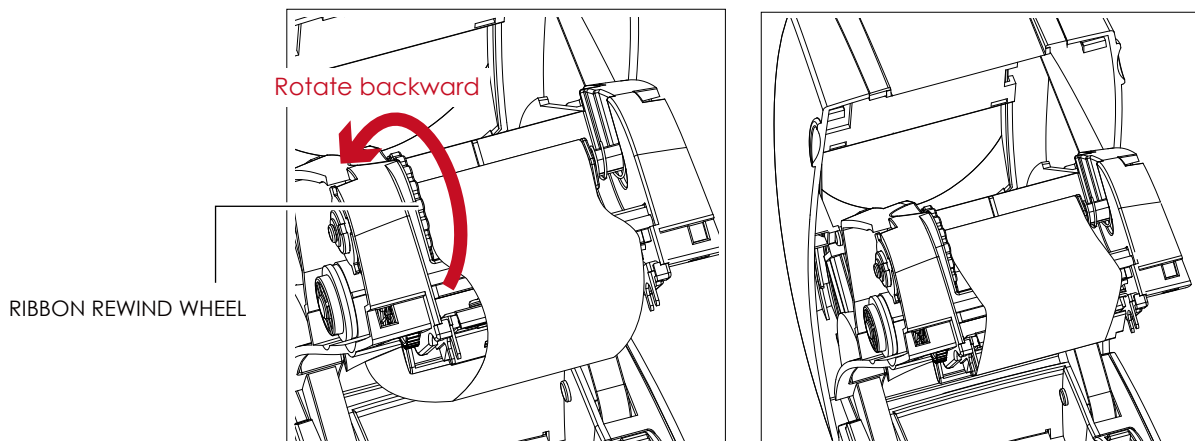

## 2 Printer Setup

### 2.3 Loading the Label Roll Module

#### A New Label Supply Module Loading

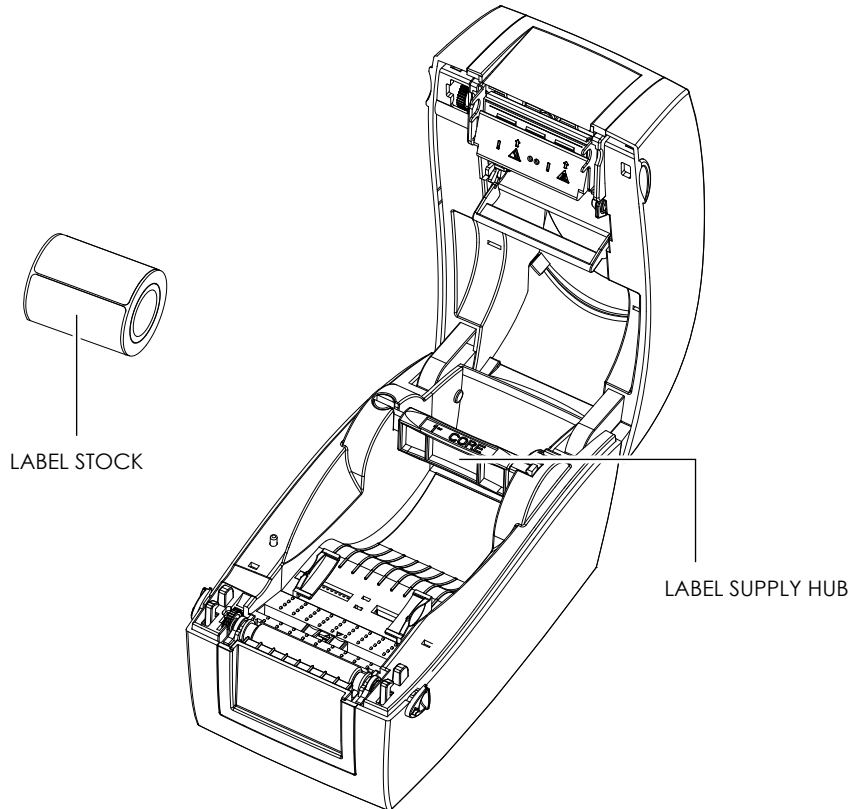

1. Unlock the release catch to lift the label supply hub.

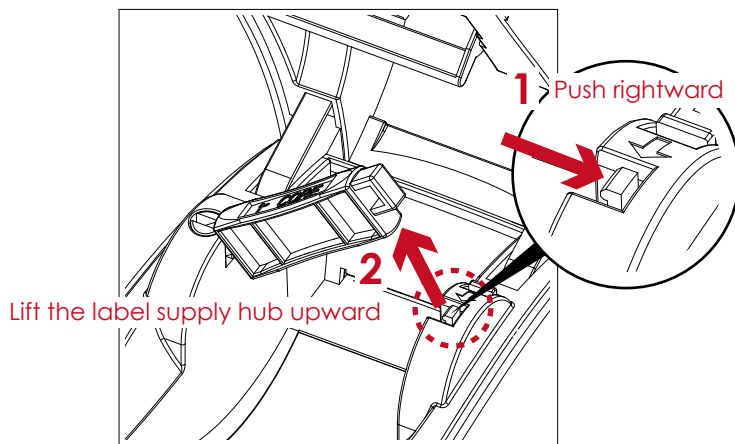

2. Place the label stock on the label supply hub.

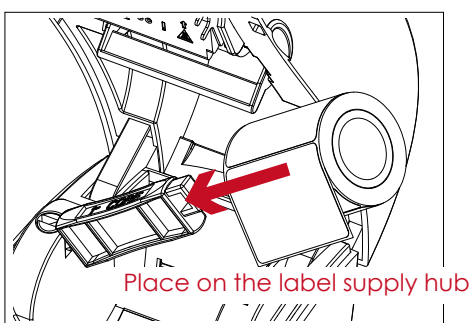

## 2 Printer Setup

3. Push the label supply module downward and close the release catch.

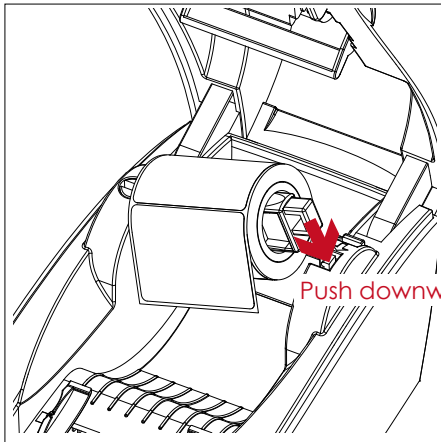

Push downward to fix the module

4. A new label supply module is completed.

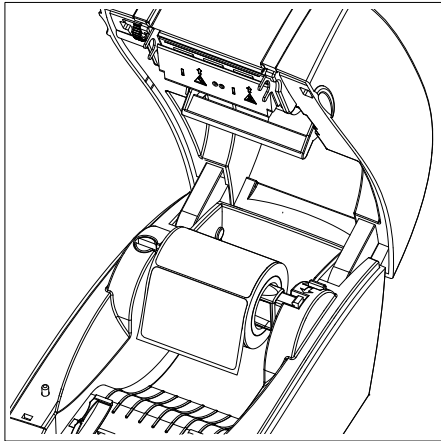

### Loading the Label Roll Module on the Printer

1. Feed the Label through the label guides and adjust the label guides to the label width. The label guides will help to prevent the label swaying.

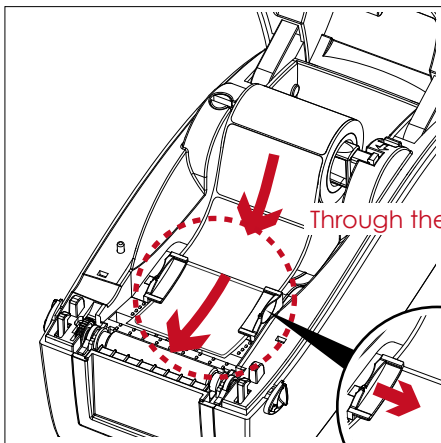

Through the label guides

Adjust the label guides

## 2 Printer Setup

2. Unlock the release catch to close the printer cover.

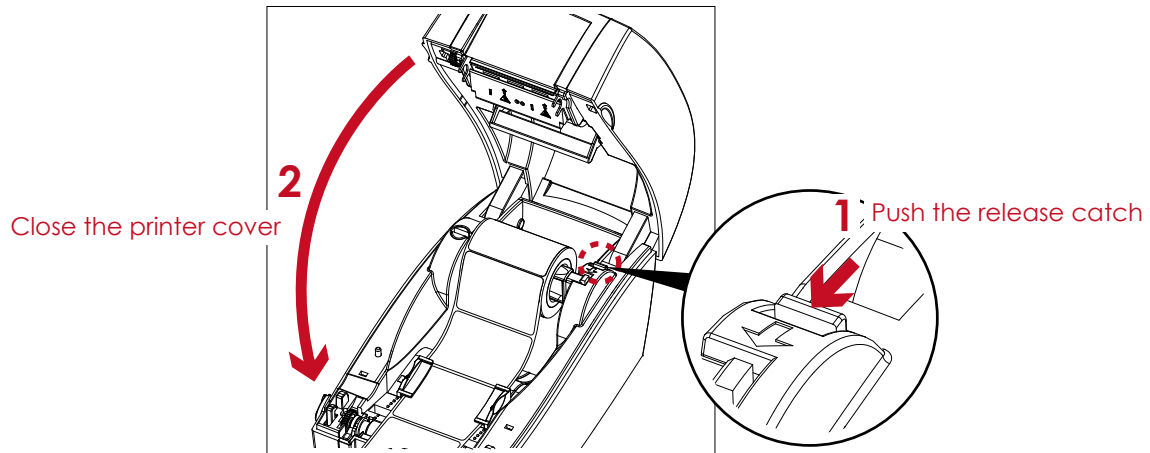

3. Press the FEED key and make sure the label is fed smoothly. The label loading is completed now.

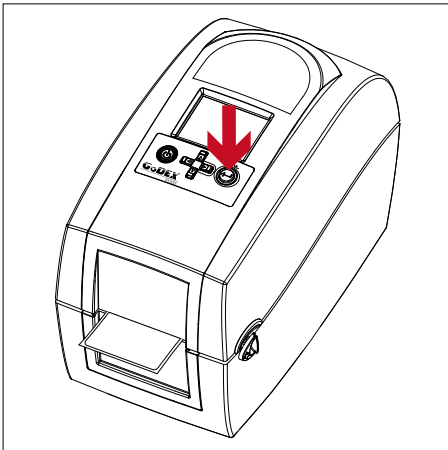

### Notice

- \* Please keep the rack gear clean to ensure the smoothness of label holder.

## 2 Printer Setup

### 2.4 Connecting the Printer to the Host Computer

1. Please make sure that the printer is switched off.
2. Connect the power cord to the AC adapter.

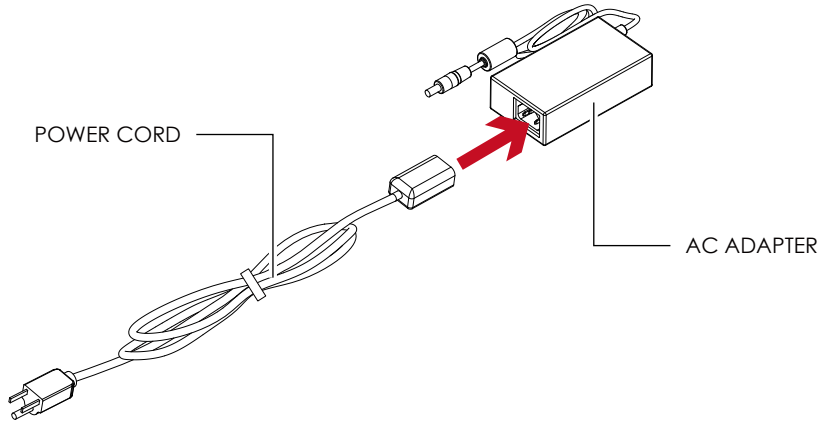

Connect the jack of the power adapter to the printer and connect the plug of the power adapter to the socket of the wall.

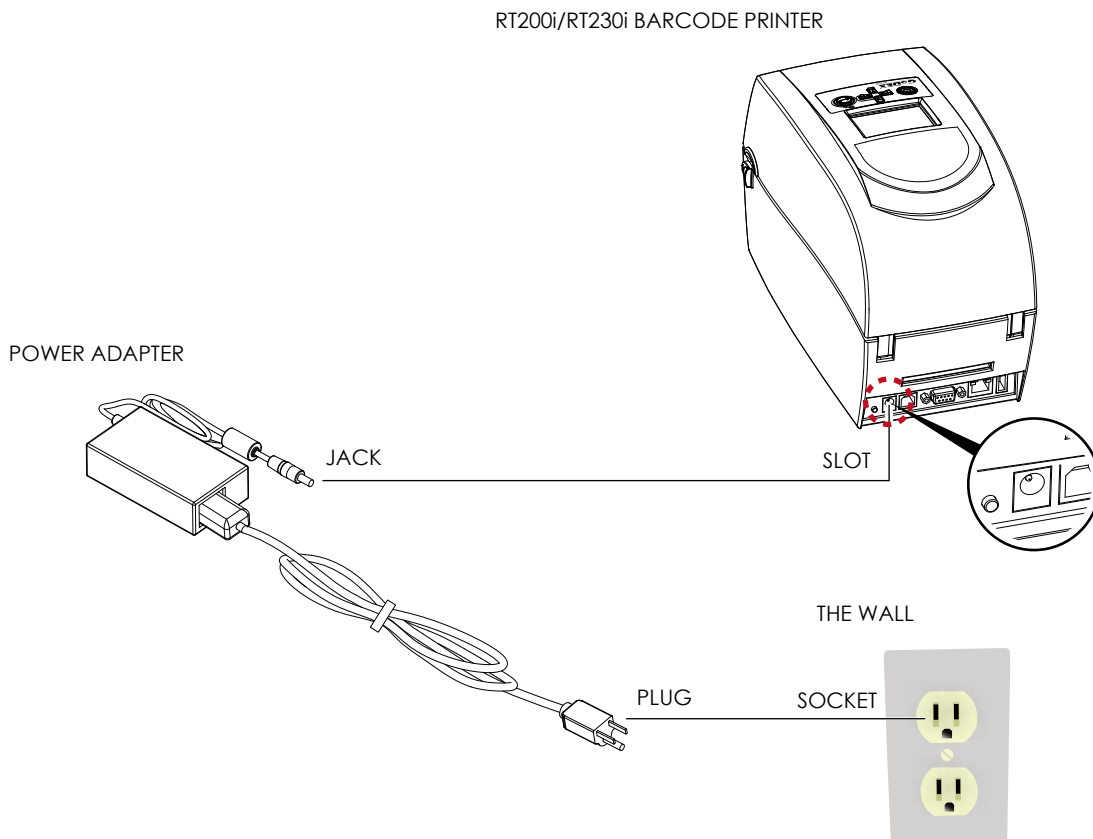

## 2 Printer Setup

3. Connect the USB/serial cable to the printer and host computer.

RT200i/RT230i BARCODE PRINTER

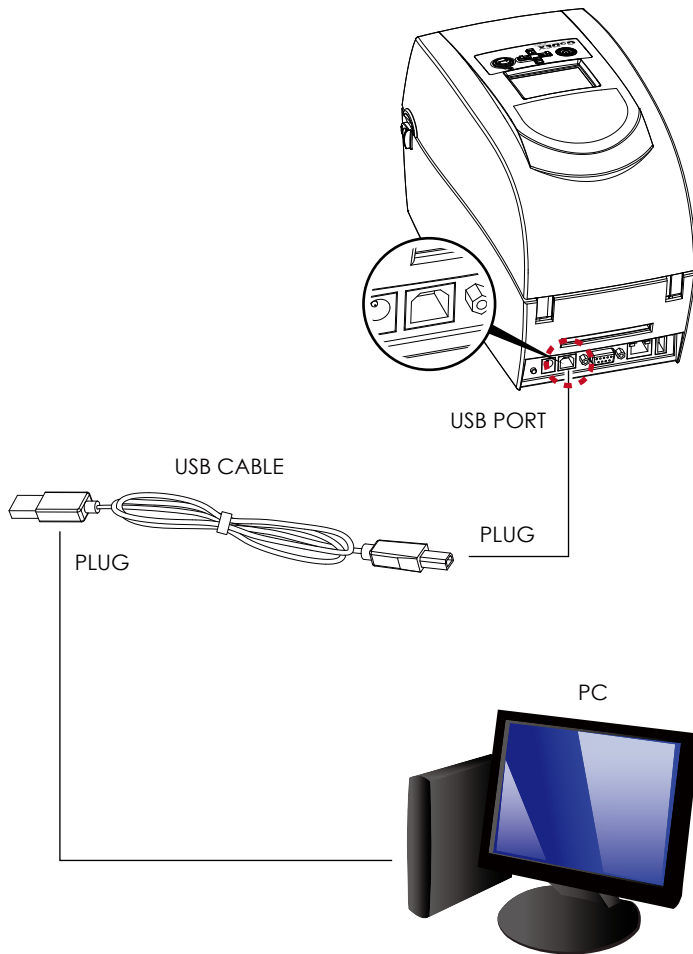

4. Pressing the POWER button. The LCD screen should now lights up.

Pressing the POWER button

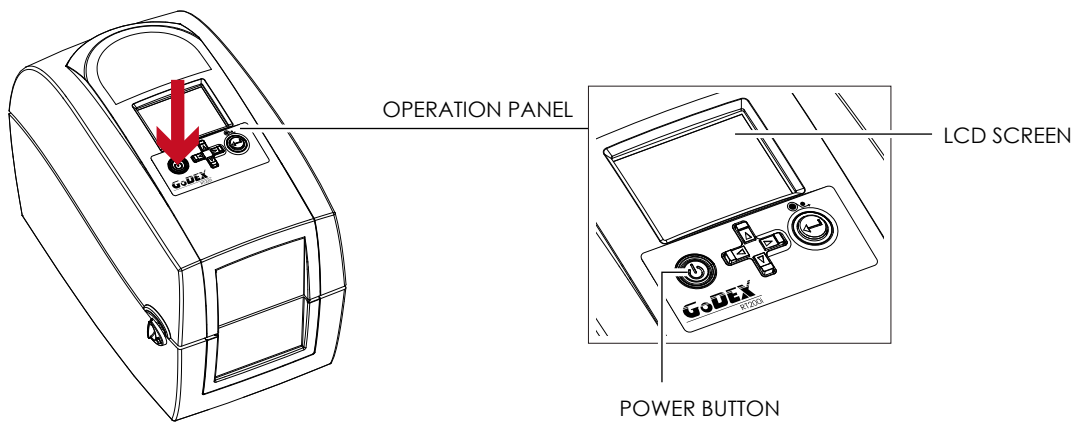

## 2 Printer Setup

### 2.5 Installing Printer Driver and GoLabel with Super Wizard CD

1. Insert the Super Wizard CD in the CD/DVD drive of the host computer and the program should pop up automatically. You will see the Welcome screen first. On the Welcome screen, choose "Standard Installation".



2. The wizard will then ask you to make sure your USB and power cables are connected and that the power is turned on. Make sure that is done and then click "Next".



3. The next screen you will see is, "Install the GoLabel Software and Windows driver". Click "Next" to continue.



### Notice

- \* If the Super Wizard program did not run automatically, you can either turn on the "Auto-run" setting for your CD/DVD driver or double-click the icon of CD/DVD driver to run the program.

## 2 Printer Setup

4. As the printer driver and GoLabel are installing, a screen will display a progress bar.



5. Once the installation is complete, you can start to make and print labels with GoLabel or through the printer driver.



6. As the optional steps, you can also print a test label or register your printer during the "Standard Installation" procedure.



### Notice

- \* If you need more resources, tools or reference documents, you can also find them on Super Wizard CD. Just click "Other Choices" on Welcome Screen to access the files.



## 2 Printer Setup

### Installing Printer Driver Directly From CD Folder

1. Insert the product CD in the CD/DVD drive of the host computer and open the "Seagull Drivers" folder on the CD. Select the icon for the driver file and click it to start the installation.

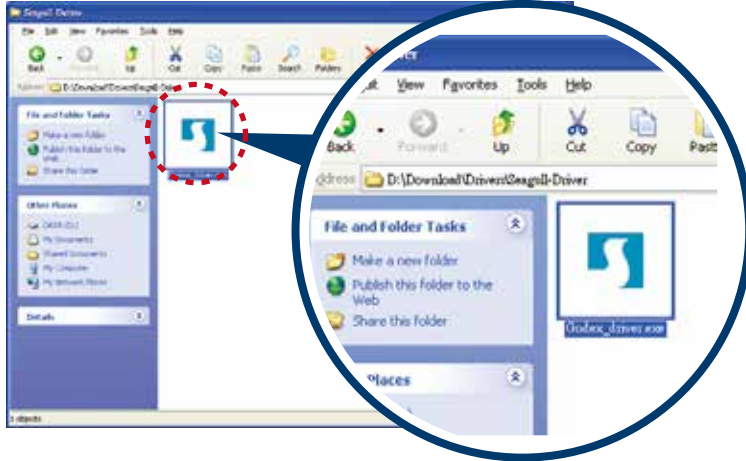

2. Follow the instructions on the screen. The Driver Wizard guides you through the installation procedure. Select "Install printer drivers".



3. Specify your printer model.



## 2 Printer Setup

- Specify the port used to connect the printer to the host computer.

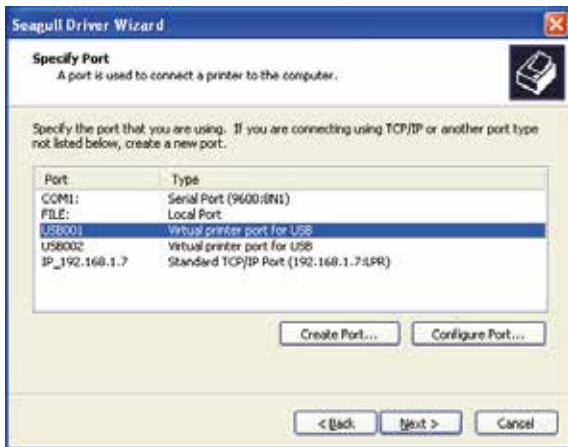

- Enter a printer name and assign the appropriate rights.



- Once the installation is complete, a summary of the printer settings is displayed. Check whether the printer settings are correct and click "Finish" to start copying the driver files. Wait until copying is complete, then finish the installation.



## 2 Printer Setup

7. Once the driver installation is complete, the new printer should appear in the "Printers and Faxes" folder.

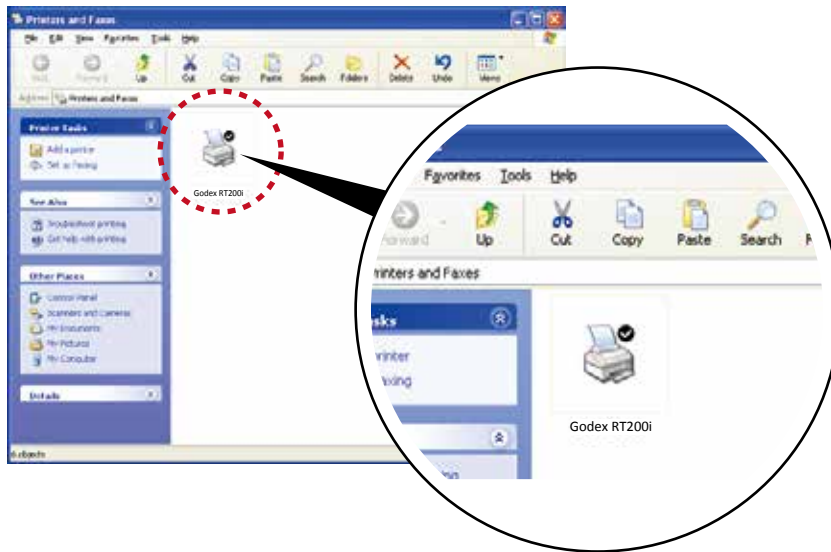

# 3 Setting and Control for Operation Panel

## 3.1 Operation Panel

### Operation Panel Introduction

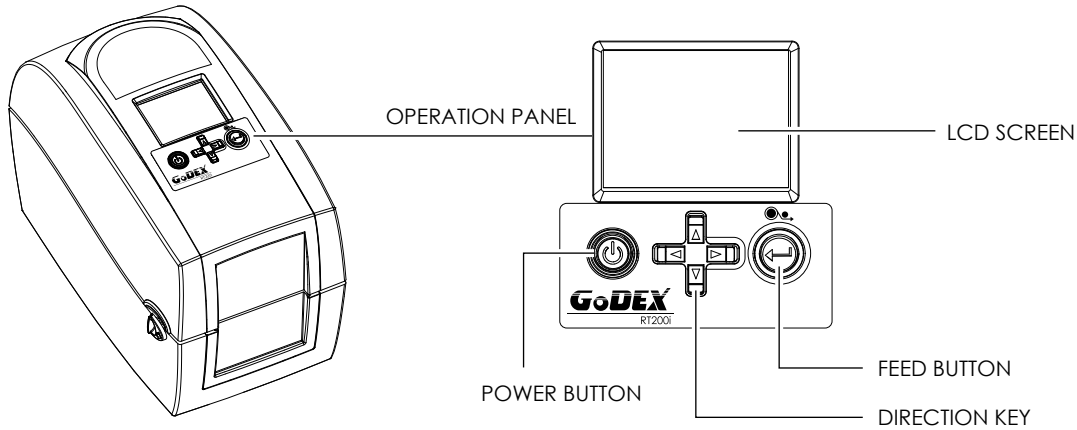

#### POWER Button

Press the POWER button to turn on the printer, and the START UP SCREEN appears. The printer is on “ready to print” status, the LCD screen should display the message “READY” on the screen.

When printer is turned on, keep pressing the POWER button for 3 second will turn the printer off.

#### FEED Button

When you press the FEED button, the printer moves the label to the defined stop position.

If you are using continuous labels, pressing the FEED button will move label stock until you release the button again.

If you are using individual labels, pressing the FEED button will move only one label.

If the label does not stop at the correct position, you need to run the auto-detection function on the label stock, please see Section 3.4 Label Calibration and Self Test.

# 3 Setting and Control for Operation Panel

## 3.2 LCD Interface Introduction

### Getting Started

Press the POWER button to turn on the printer, and the START UP SCREEN appears.

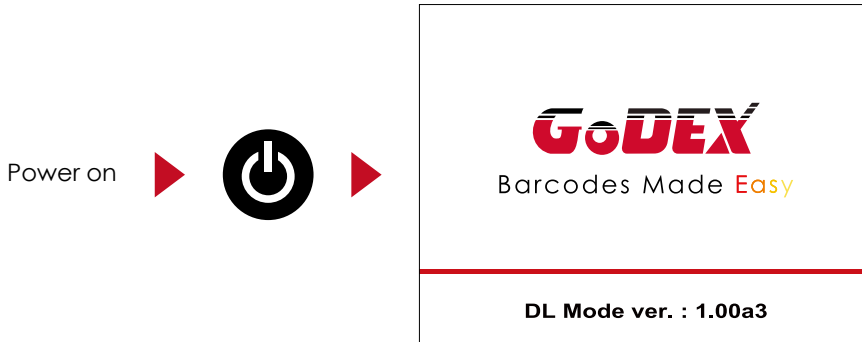

If the printer is on "ready to print" status, the LCD screen should display the message "Ready" on the screen.



Please keep pressing ▶ button and wait for the timer to be filled, then the LCD interface will enter into the MAIN PAGE for SETTING MODE. You can make various setting functions in SETTING MODE.

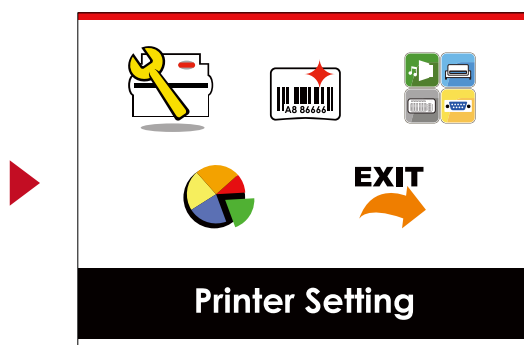
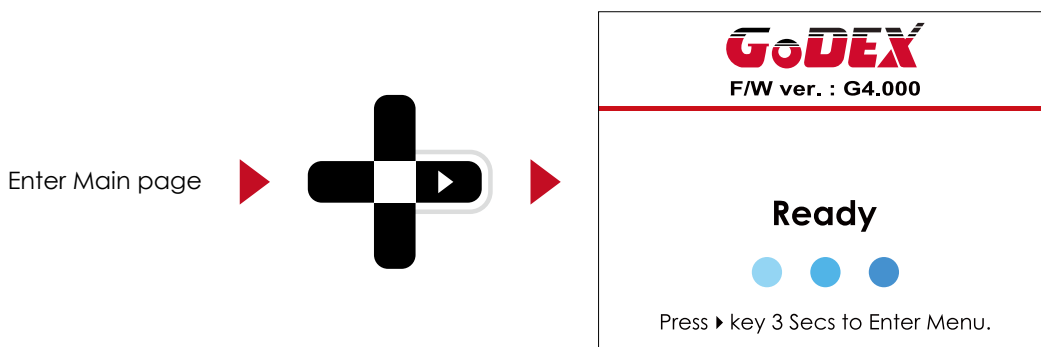

# 3 Setting and Control for Operation Panel

## Operations on Setting Page

On MAIN PAGE, press ▶ or ◀ button to move the cursor and select the functions.

Select a designated function and press FEED button, you will enter the SETTING PAGES for the function.

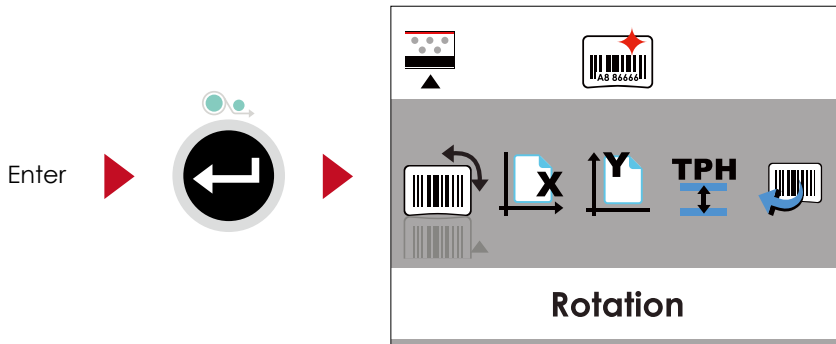
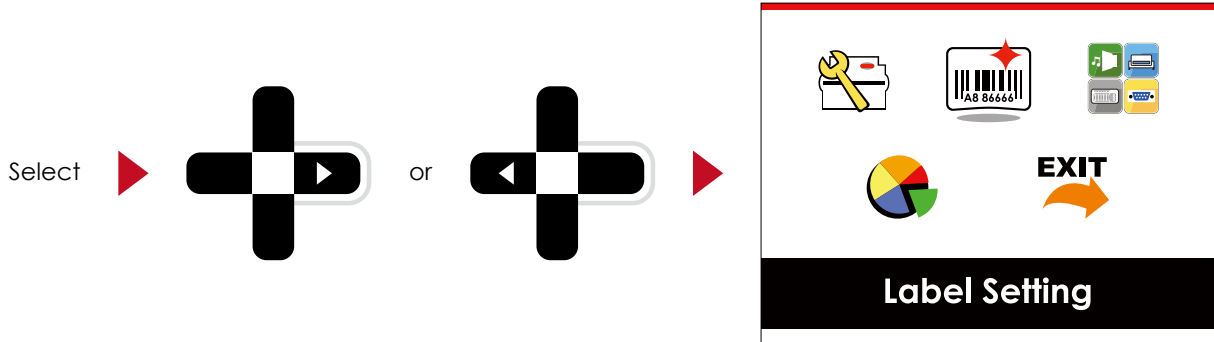

On SETTING PAGES, press ▶ or ◀ button to select the setting items.

Select a designated function and press FEED button, you will enter the SETTING VALUE PAGES for the function.

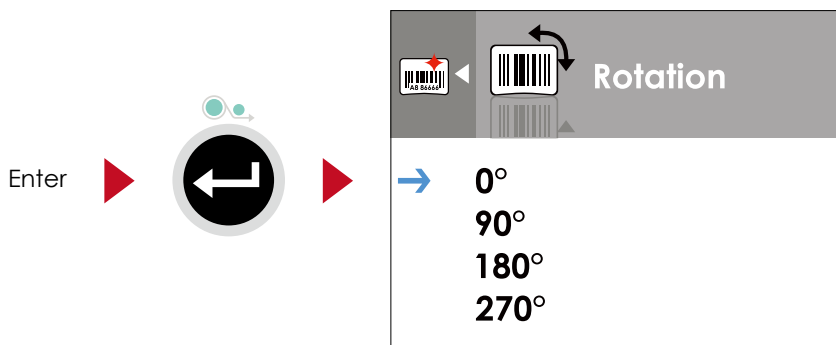
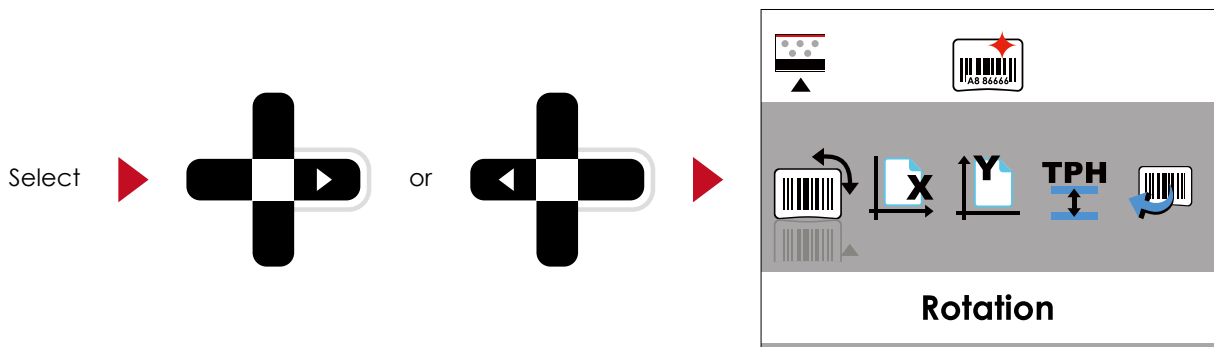

### 3 Setting and Control for Operation Panel

On SETTING VALUE PAGES, press ▲ or ▼ button to change the setting values.

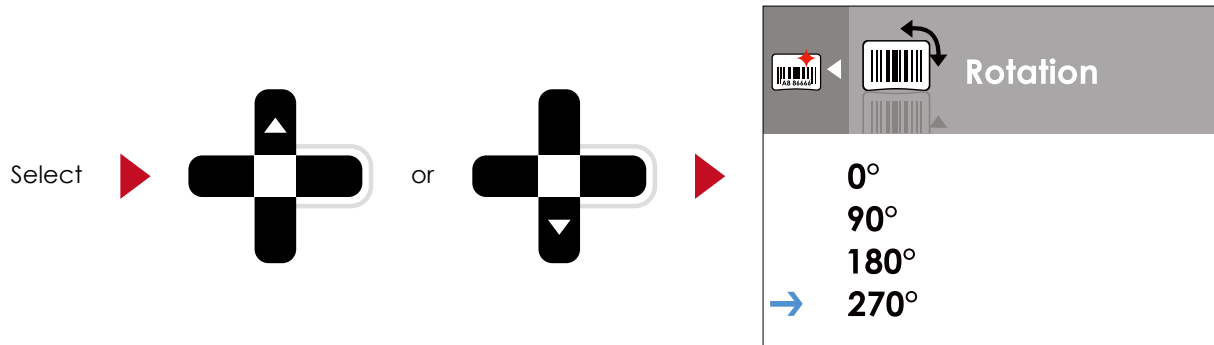

Press FEED button will apply the setting value you just selected, and the red tick will appear to mark the value.

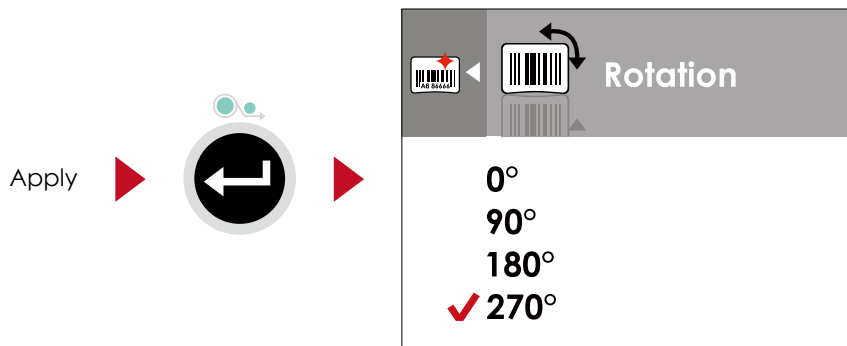

#### Notice

\* The blue arrow indicates the value you are selected.



\*\* The red tick indicates that the selected value is applied now.



### 3 Setting and Control for Operation Panel

#### Exit from Current Page to Ready Status

The icon on top-left corner displays the capture of upper level screen and also guides you back to upper level with left or up arrow.

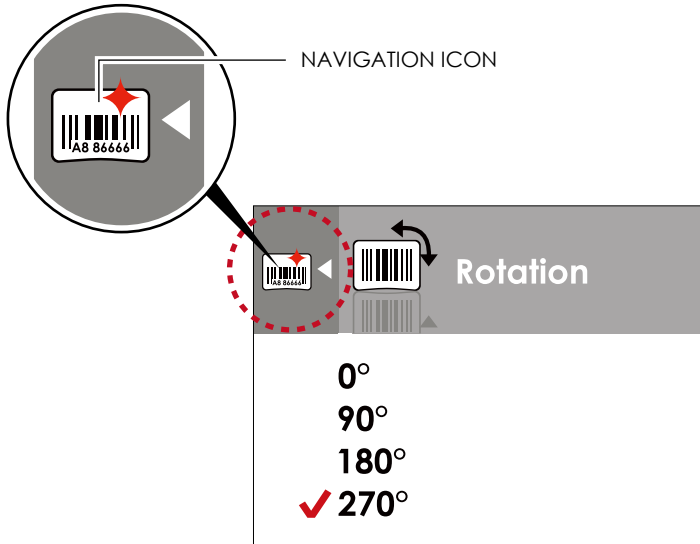

On SETTING VALUE PAGES, press ◀ button will go back to the upper level screen.

Back to the Setting page

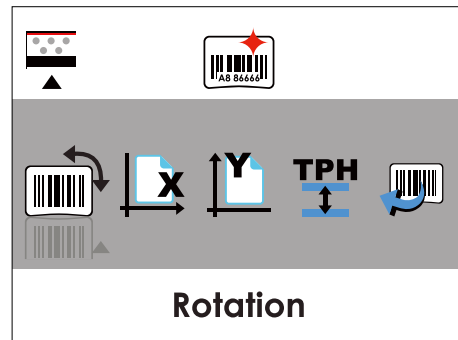

On SETTING PAGES, press ▲ button will go back to the MAIN PAGE screen.

Back to the Main page

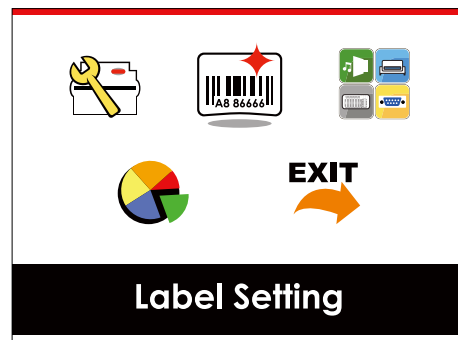
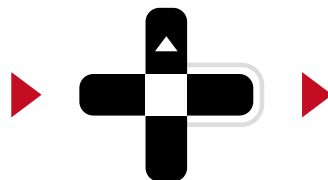



### 3 Setting and Control for Operation Panel

On MAIN PAGE, select the "EXIT" icon and press the FEED button to exit from SETTING MODE and the printer goes back to READY status.

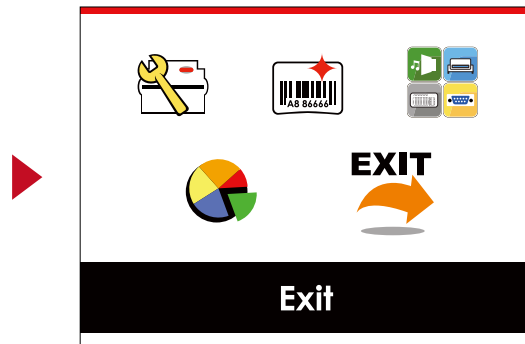
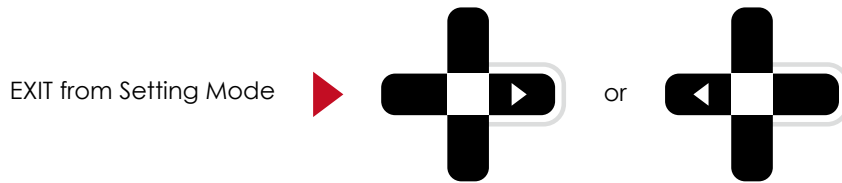

# 3 Setting and Control for Operation Panel

## 3.3 LAN Setting

Operations on Setting Page

On MAIN PAGE · press ▶ or ◀ button to move the cursor and select the functions.

Select a designated function and press FEED button, you will enter the SETTING PAGES for the function.

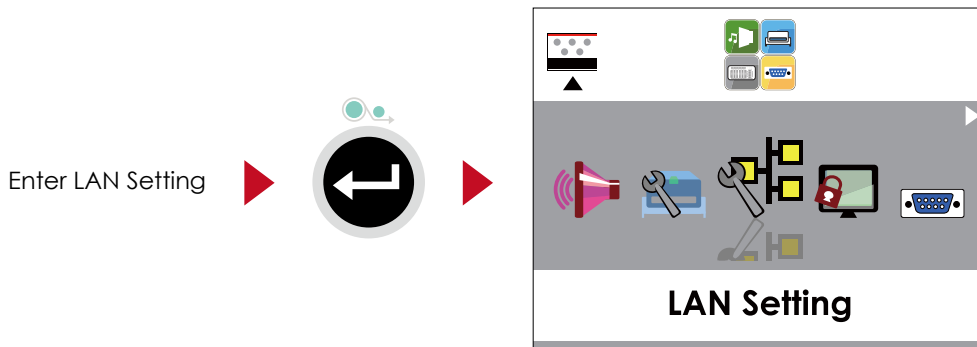
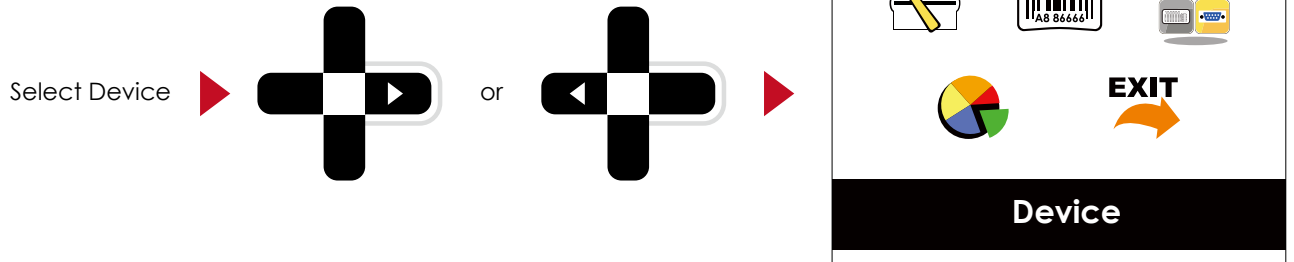

On LAN Setting PAGE · press ▶ or ◀ button to select the setting items.

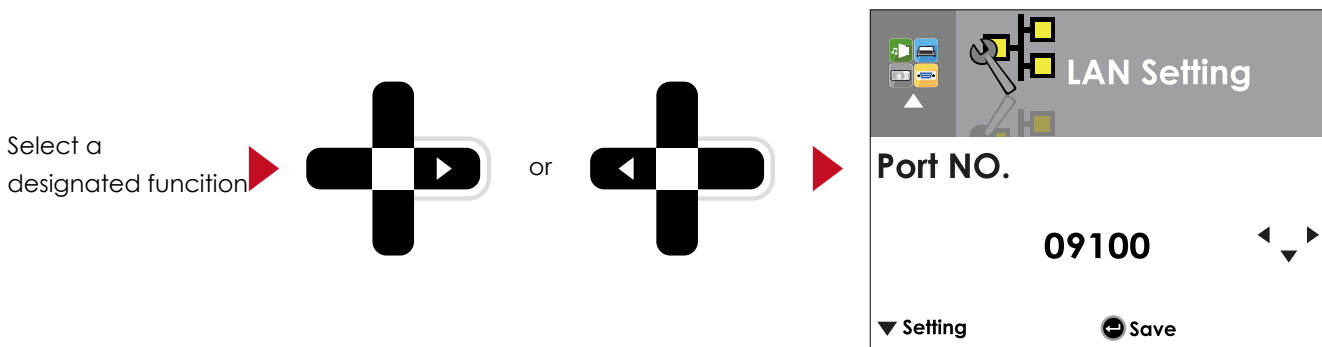

Select DHCP and press FEED button, you will be able to setup DHCP function

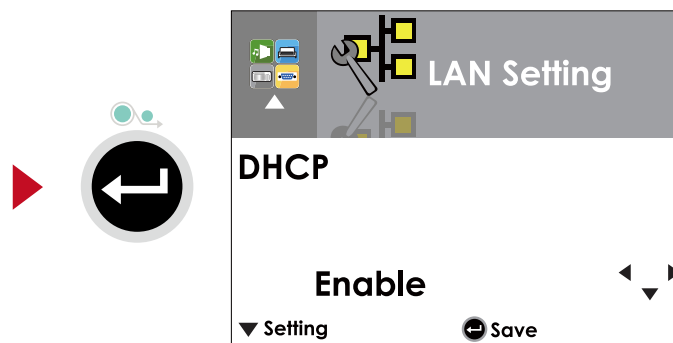

### 3 Setting and Control for Operation Panel

The default of DHCP is Disable. · Press ▲ or ▼ button to change the setting values.

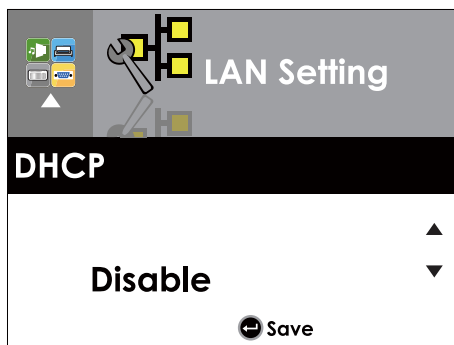

Select ▼ to enable DHCP

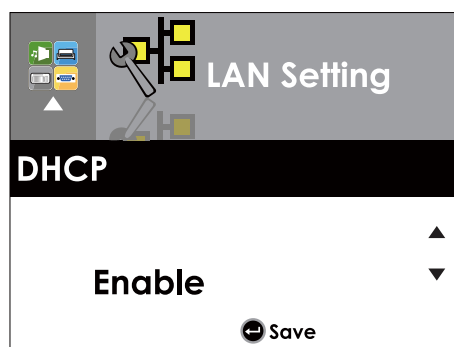
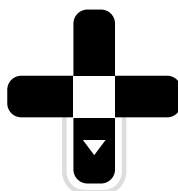

Press FEED button twice to save the setting.

Press FEED once to exit.

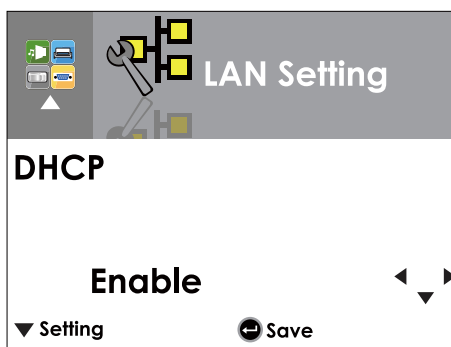

Press FEED again to save and return to previous SETTING PAGE.

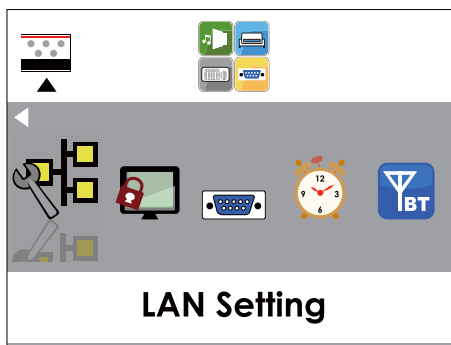

# 3 Setting and Control for Operation Panel

## 3.4 LCD Password

Operations on Setting Page

On MAIN PAGE, press **▶** or **◀** button to move the cursor and select the functions. Select a designated function and press FEED button, you will enter the SETTING PAGE for the function.

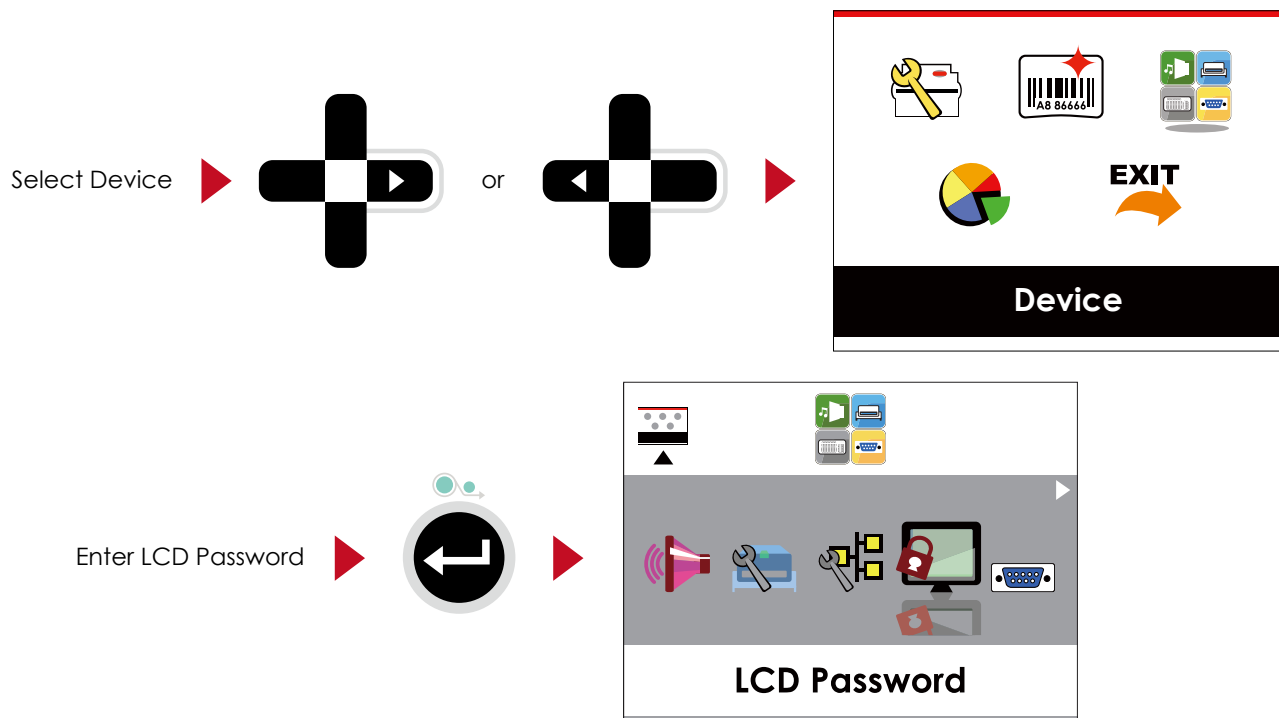

The default of LCD Setting is Disable. Press **▲** or **▼** button to change the setting values.

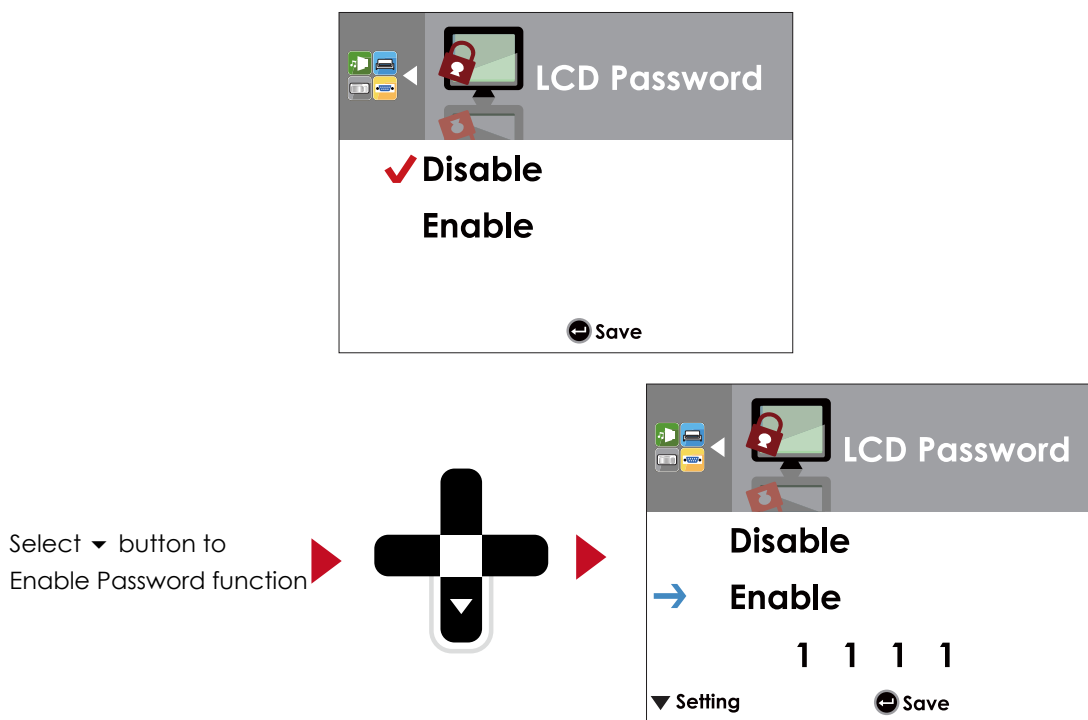

### 3 Setting and Control for Operation Panel

Select ▼ button again to setup the password

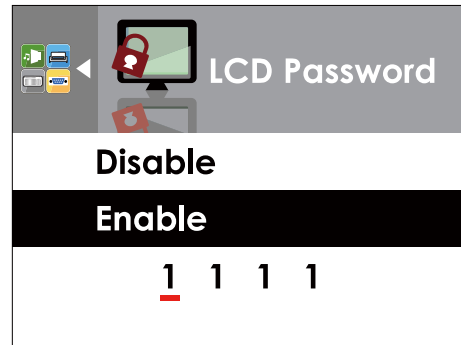
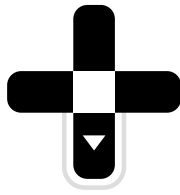

Press FEED button twice to save the setting

Press FEED button once to exit.

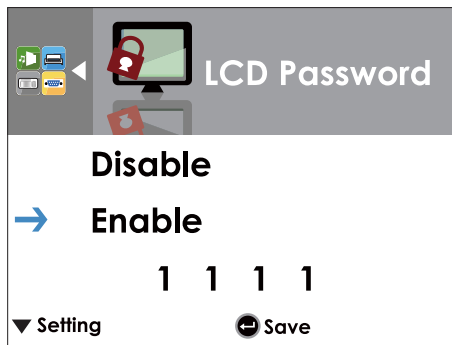

Press FEED button again to save and return to previous SETTING PAGE

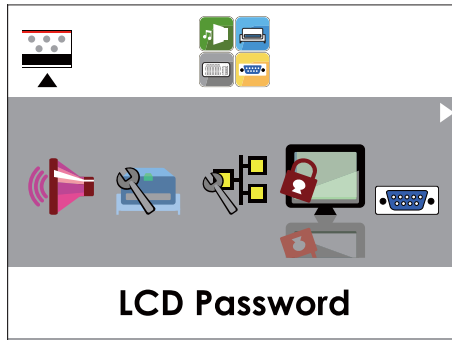

# 3 Setting and Control for Operation Panel

## 3.5 LCD Interface Function

### Main Page

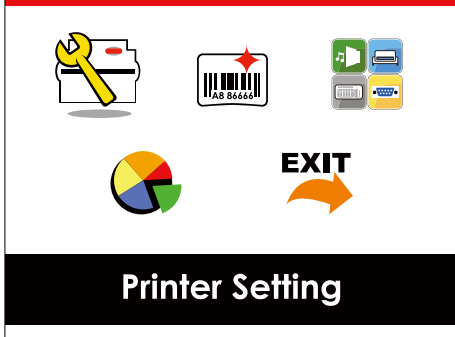

  
Printer Setting

---

Setting items for printer, ex. Printing speed, darkness.  
Also includes a Printing Wizard for your ease of printing.

  
Label Setting

---

Setting items for printing label, ex. Rotation, Printing position offset.

  
Device

---

Option modules and connection port settings.

  
Analysis

---

Self-Diagnose functions for printer, ex. TPH testing, self-test page printing.

  
Exit

---

Exit from Setting Mode.

---

# 3 Setting and Control for Operation Panel

## Setting Items in Setting Mode



LCD Language		English	
		German	
		繁體中文	
		简体中文	
	Speed		2-5 or 7
		Darkness	0-19
	Wizard	Media Type	Label with Gaps
			Label with Marks
			Continuous
		Printer Mode	Direct Thermal
		Thermat Transfer	
	Tear-off Position	0-40	
	Darkness	0-19	
	Speed	2-5 or 7	
Sensor	Media Detection	Auto Select	
		See-Through	
		Reflective	
Media Type	Label with Gaps		
	Label with Marks		
	Continuous		
Printing Mode	Direct Thermal		
		Thermat Transfer	
	Tear-off Position	0-40	
Top of Form		Apply	
		Cancel	
Setting		850	
		852	
		437	
		860	
		863	
		865	
		857	
		861	
		862	
		855	
	Codepage		866
			737
			851
			869
			Win 1252
		Win 1250	
		Win 1251	
		Win 1253	
		Win 1254	
		Win 1255	
	Win 1257		



Rotation		0°
		90°
		180°
		270°
	Horizontal Offset	-100 - 100
Vertical Offset	-100 - 100	
Start Offset	-100 - 100	
Recall Label		001 Form Name
		002 Form Name

# 3 Setting and Control for Operation Panel



Device

Buzzer		Apply
		Cancel
		None
Optional Setting	Option	Cutter
		Label Dispensor
		Applicator
	Pre-Printing	Apply
		Cancel
LAN Setting	Part NO.	09100
	DHCP	Disable
		Enable
	Default Gateway	192.168.000.254
	Dynamic IP	192.168.102.076
	Subnet Mask	255.255.255.000
LCD Password		Disable
		Enable
Serial Port Setting	Baud Rate	4800 bps
		9600 bps
		19200 bps
		38400 bps
		57600 bps
		115200 bps
	Parity	Non
Odd		
	Even	
Data bits	7 bits	
	8 bits	
Stop bits	1 bits	
	2 bits	
RTC Setting	Clock Display	Apply
		Cancel
	RTC Setting	YYYY/MM/DD
		HH:MM:SS



Analysis

Calibration		Apply
		Cancel
Self-test		Apply
		Cancel
TPH Testing		Apply
		Cancel
Reset to Default		Apply
		Cancel
Clear Memory	Label Format	Apply
		Cancel
	Graphic	Apply
		Cancel
	Bitmap Fonts	Apply
		Cancel
	True Type Fonts	Apply
	Cancel	
	Asian Fonts	Apply
		Cancel
	ALL	Apply
		Cancel



Exit

Exit		
------	--	--



# 3 Setting and Control for Operation Panel

## Status of LCD Interface





When printer is on standby status (ready to print), the LCD interface will display "Ready" on screen. You can only print on this "Ready" status.

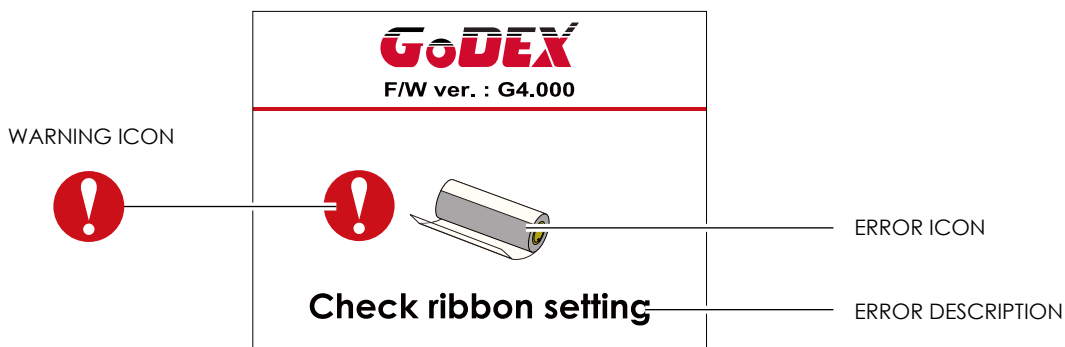

If there is any printers error, the LCD screen will display the error screen to show the type of error. You can fix the error according the notice.



## Icon Definition

	To upper level	Appears on the NAVIGATION ICON of Setting Pages. It guides you back to upper level by pressing "LEFT" key.
	To upper level	Appears on the NAVIGATION ICON of Setting Value Pages. It guides you back to upper level by pressing "UP" key.
	Lock	On Setting Value pages, press "RIGHT" key to lock the value for preventing unexpected change.
	Unlock	For locked value, press "RIGHT" key again to unlock the value.
	Scroll the value	On Setting Value pages, press "UP" or "DOWN" key to scroll the values for your selection.

# 3 Setting and Control for Operation Panel

## 3.6 Label Calibration and Self Test

### Label Calibration

The printer can automatically detect and store label height.

That means the host computer does not need to transmit the label height to the printer.

### Self Test

Self-test function lets you check whether the printer is functioning normally.

Here is how you run the label size calibration and self test.

1. Check that the label stock is loaded correctly.
2. Turn off the printer.
3. Turn the printer on again, keeping the FEED button pressed. The printer will now measure the label stock and store the label height.
4. Once the printer has successfully measured the label stock, it will print a self-test label.

The contents of a self-test printout are listed below.

Model & Version	RT200i:GX.XXX
USB ID setting	USB S/N:12345678
Serial port setting	Serial port:96,N,8,1
MAC address of Ethernet port	MAC Addr:xx-xx-xx-xx-xx-xx
IP protocol setting	DHCP Enable
IP address of Ethernet port	IP xxx.xxx.xxx.xxx
Gateway setting	Gateway xxx.xxx.xxx.xxx
Netmask setting	Sub-Mask xxx.xxx.xxx.xxx
	#####
Number of DRAM installed	1 DRAM installed
Image buffer size	Image buffer size:1500 KB
Number of forms	0000 FORM(S) IN MEMORY
Number of graphics	0000 GRAPHIC(S) IN MEMORY
Number of fonts	000 FONT(S) IN MEMORY
Number of Asian fonts	000 ASIAN FONT(S) IN MEMORY
Number of Databases	000 DATABASE(S) IN MEMORY
Number of Scalable fonts	000 TTF(S) IN MEMORY
Free memory size	4073 KB FREE MEMORY
Speed, Density, Ref. Point, Print direction	^S4 ^H8 ^R000 ~R200
Label width, Form length, Stop position	^W102 ^Q100,3 ^E18
Cutter, Label Dispenser, Mode	Option:^D0 ^O0 ^AD
Sensor Setting	Reflective AD:1.96 2.84 2.49[0.88_23]
Code Page	Code Page:850

# 3 Setting and Control for Operation Panel

## Label Calibration Button

A hardware button to make a Label Calibration while printer encountering "Media Error" during the cases when first-time printer start up or change label or ribbon to another type, such as change using gap label to continuous or black mark labels.

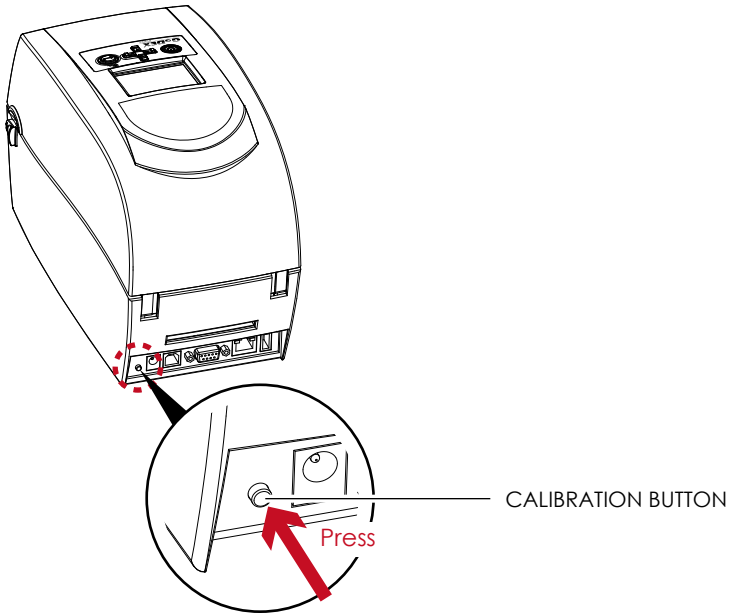

Press C-button for 2 seconds, it will make an auto-sensing to calibrate the label and ribbon's parameters.

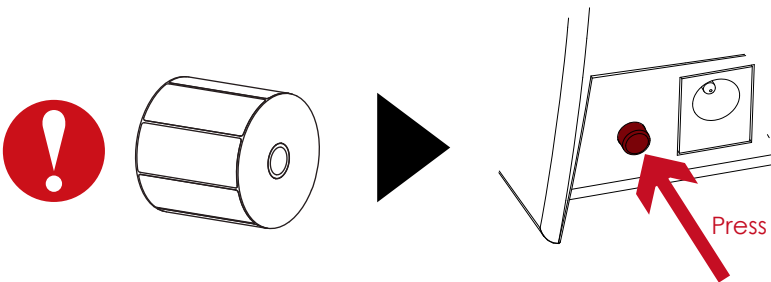

## Notice







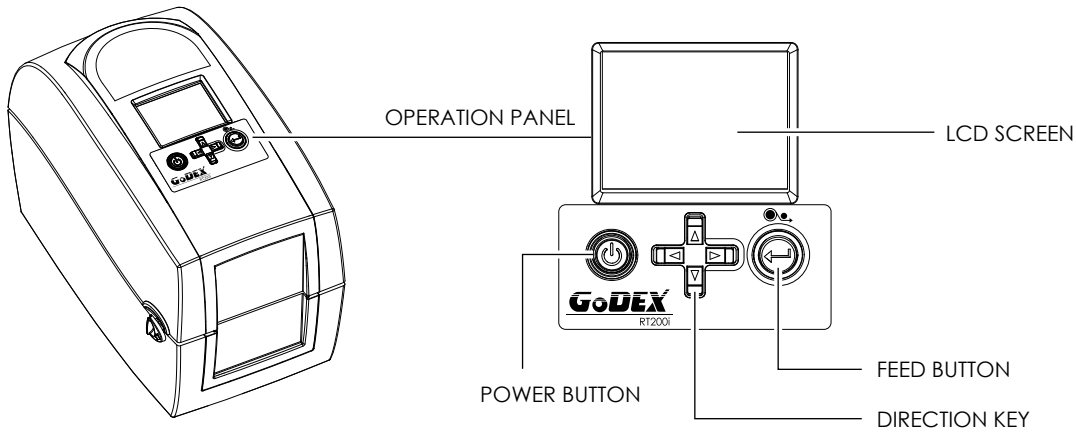

\* Press C-button is equivalent to the auto-sensing command "'~S,SENSOR'" that will cancel on-printing-job and make the Label Calibration immediately.

# 3 Setting and Control for Operation Panel



## 3.7 Error Alerts

In the event of a problem that prevents normal functioning of the printer, you will see an error message on LCD screen and hear some beep signals. Please refer to below table for the error alerts.

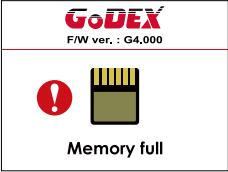

Operation Panel Status	Type	Beeps	Description	Solution
  <p>TPH opened</p>	Print Head Error	2 x 4 beeps	The printing mechanism is not correctly closed.	Open the print mechanism and close it again.
  <p>TPH overheat</p>	Print Head Error	None	High temperature at the print head.	Once the print head has cooled down, the printer switches to standby mode.
  <p>Check ribbon setting</p>	Media Error	2 x 3 beeps	No ribbon is installed and the printer displays an error. The ribbon is finished or the label supply hub is not moving.	Make sure that the printer is set to direct thermal printing mode. Replace the ribbon roll.
  <p>Check paper setting</p>	Media Error	2 x 2 beeps	No paper is detected. Paper is finished. Printer feed problem.	Make sure that the label sensor is positioned correctly. If the sensor still does not detect the paper, run the auto-detection function again. Replace the label roll. Possible reasons: the print medium has become trapped around the rubber roll; the sensor cannot detect a gap or black mark between the labels; there is no paper. Please reset the sensor.

# 3 Setting and Control for Operation Panel

Operation Panel		Status		
Type	Beeps	Description	Solution	
 <p>GoDEX F/W ver. : G4.000 Memory full</p>		The memory is full. The printer prints the message "File System full".	Delete unnecessary data or install additional memory.	
 <p>GoDEX F/W ver. : G4.000 File name can't be found</p>	File Error	2 x 2 beeps	Unable to find file. The printer prints the message "File Name not found".  Use the "~X4" command to print all files. Then check whether the files exist and whether the names are correct.	
 <p>GoDEX F/W ver. : G4.000 File name duplicated</p>		A file of the same name already exists. The printer prints the message "Duplicate Name".	Change the name of the file and try storing it again.	

# 3 Printer Setting and Control

## 3.8 USB Host

Definition : USB Host port supports either device : USB memory stick, keyboard or scanner.

### Purpose

- USB memory stick : It extends the user memory space up to 32GB for Graphic, Font, Label Format, DBF and Command files downloading. The printer's Firmware also can be updating if copy new version of Firmware into USB memory stick.
- Connecting an USB keyboard to printer for " Standalone" mode operation.
- Plug-in an USB scanner to operate the printer in "Standalone" mode.

### Usage of Extended Memory

- USB memory stick : It supports hot-plugging function; printer will create a Folder "\LABELDIR" and switch "User Flash" to " Extended Memory" automatically while user plugs an USB memory stick into a GoDEX "i" model printer.
- Connect the USB Stick plugged -in printer to PC via USB Device or Ethernet port and run "GoLabel" software to download Graphic, Font, Label Format, DBF and Command files to the printer.
- Detail download procedures, please refer to "GoLabel On-line Help".

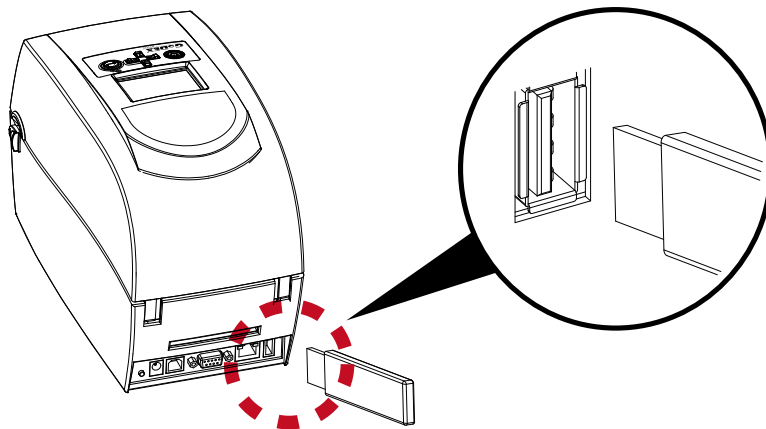

### Usage of Firmware Update

- Remove USB memory stick from printer and plug-in it to a PC's USB port; delete Firmware "\*.bin" file from "\LABELDIR\FW" of USB memory stick if it existing; or create a Folder "\LABELDIR\FW" to USB memory stick if it doesn't existing.
- Copy a new version of Firmware "xxxx.bin" to the Folder "\LABELDIR\FW"; and then remove USB and plug-in back to the printer that going to update Firmware.
- The printer will update the Firmware automatically when plug-it-into the printer and printer find-out the Firmware in "\LABELDIR\FW" is newer version.
- Don't remove the USB memory stick out while it's under updating with "Flash Writing..." message that displays on LCD panel.

# 3 Printer Setting and Control

## USB Keyboard

- When plug-in an USB keyboard to the printer, LCD panel will display "Standalone Mode", press the "Enter" key on keyboard and "Feed" key in the printer to entering to the dialog for "Recall Label" operation.
- Only the sub-dialog "Recall Label" is able operating by keyboard as follow definition:
  1. Press "ESC" key to exist from "Standalone Mode" or back to previous dialog
  2. Press "F1", it will let the printer from "Ready" mode entering into "Standalone Mode"
  3. Press "Enter", "Arrow" and "Alphabetic" keys as the usual in PC that will perform the key-in function of "Recall Label" in "Standalone Mode".

## Scanner

- When plug-in an USB scanner to the printer, LCD panel will display "Standalone Mode", press the "Feed" key in the printer to entering the dialog of "Recall Label" operation. User performs the "Recall Label" function interactively through the LCD panel, 4 direction keys, Feed key and Scanner.
- Scanner is using in "standalone Mode" to scanning the "Serial Number, Variable" and Print Quantity while the printer prompts a message on LCD panel and wait for data input.

## Notice

---

- \* The USB Host port on 'i' 'x' model printer is without 'HUB' function.
- \* The USB Memory Stick supports with 'FAT32' Disk Format and up to 32GB only. The certified venders are Transcend, Apacer, Patriot, Consair and Kingston.
- \* The download function for Graphic, Font, Label Format, DBF and Command files is operated by GoLabel of PC and must go through the a 'i' 'x' model printer itself.
- \* On a PC, user may copy entire folder '\LABELDIR' from USB memory stick to PC or vice-versa. Copy a sub-folder or individual file in '\LABELDIR' to PC or vice-versa is not supported.

# 4 NetSetting for Ethernet

## 4.1 Installing the NetSetting software

The NetSetting software is used to manage the network configurations when connecting the printer via Ethernet port. It is available on product CD or can be downloaded from official website. To install the NetSetting, please follow below steps.

1. Insert the product CD in the CD/DVD drive of the host computer and open the "Ethernet" folder on the CD.
2. Select the icon for the NetSetting installation file and click it to start the installation.

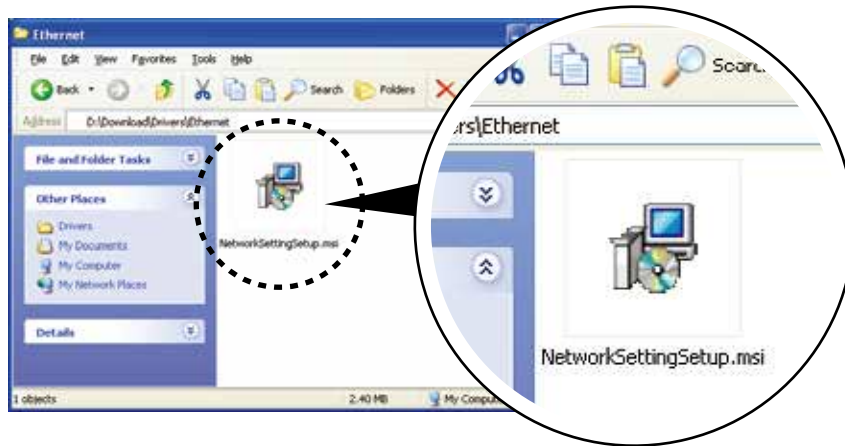

3. Follow the instructions on the screen. The Setup Wizard guides you through the installation procedure.
4. Specify the "Installation Folder".

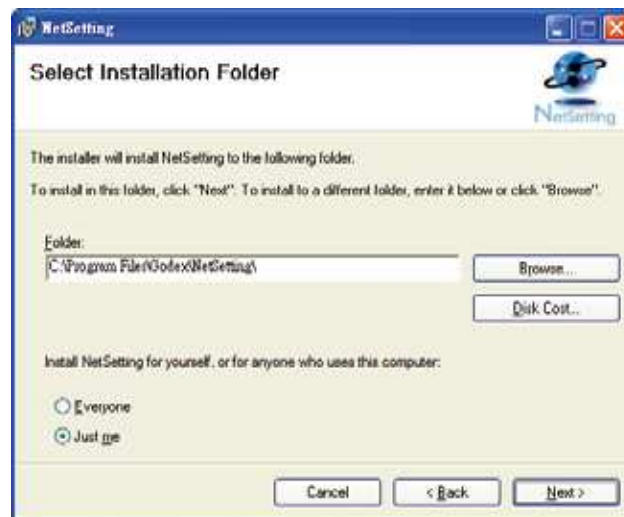

5. Click "Next" to start the installation.
6. Once the installation is completed; you will see the NetSetting icon on your desktop.





# 4 NetSetting for Ethernet

## 4.2 The Interface of NetSetting

Click the NetSetting icon to start the program; you will see the start page as below. The start page will display the basic information of connected printer and your PC.

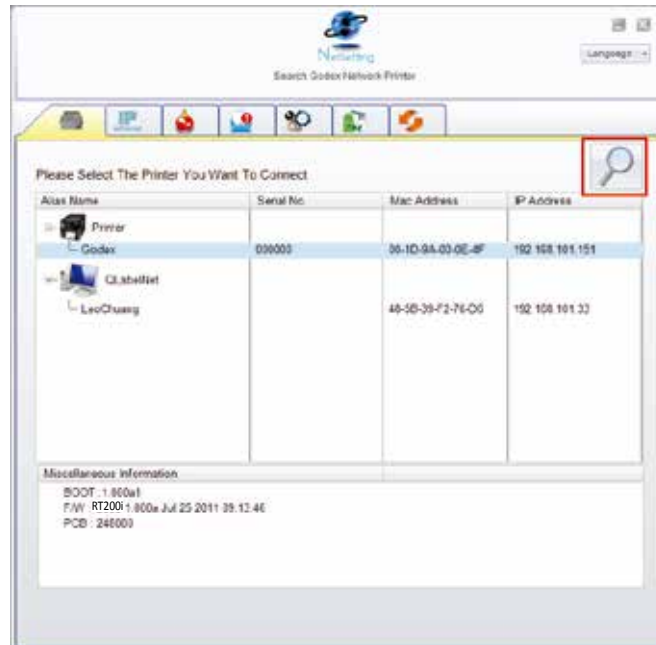

Click the magnifier icon to search the Godex printers which are connected via Ethernet port in your network environment. Once a connected Godex printer is detected, it will be listed on the start page.

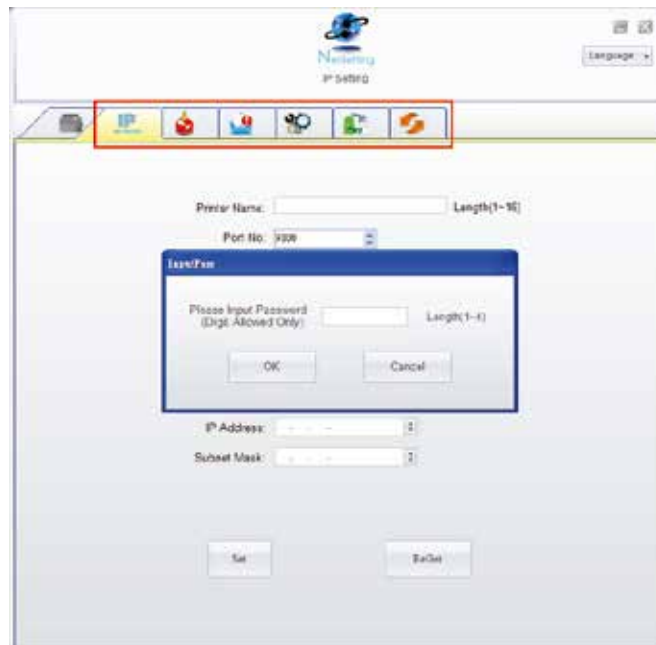

There are six tabs on the top of interface which can configure different types of network settings. But for the data security reason, you need correct password to enter the configuration pages.

### Notice

\* The default password is "1111", you can change the password later from the "IP Setting" tab.

## 4 NetSetting for Ethernet

### IP Setting

The IP Setting tab can change the printer name, Port number, Gateway setting and the password for configuring the printer. You can also set the printer's IP address either by DHCP or by Static IP.

The screenshot shows the 'NetSetting IP Setting' window. The title bar includes the 'NetSetting IP Setting' logo and a 'Language' dropdown menu. The main content area features several configuration fields: 'Printer Name' (Godex, Length(1~16)), 'Port No.' (9100), 'Default Gateway' (192.168.0.254), and 'Password' (0000, Length(1~4)). Below these are radio buttons for 'Get IP From DHCP Server' (selected) and 'Static IP'. Under 'Static IP', there are fields for 'IP Address' (192.168.101.151) and 'Subnet Mask' (255.255.255.0). At the bottom are 'Set' and 'ReGet' buttons.

You can press "Set" button to apply the settings and "ReGet" button to refresh the setting values.

### Notice

\* To fully benefit from the NetSetting software, you should be familiar with basic networking principles. Please contact your network administrator for related network setting information.

# 4 NetSetting for Ethernet

## Alert Path Setting

NetSetting will send the alert messages to designated mail account when the error happened on printer. The alert messages are sent by SMTP (Simple Mail Transfer Protocol) or SNMP (Simple Network Management Protocol). You can set or change the configurations of SMTP and SNMP on this "Alert Path Setting" tab.

**Alert Path Setting**

Language: ▾

SMTP Notification Enable

Login Account:  Length(1-64)

Login Password:  Length(1-16)

Server IP Address:   xxx.xxx.xxx.xxx

Mail Subject:  Length(1-60)

Mail From Address:  Length(1-32)

Mail To Address:  Length(1-32)

Duration Cycle:  0 ~ 168 Hours

Event Counter:  1 ~ 100

SNMP Notification Enable

SNMP Community:  Length(1-16)

SNMP Trap Community:  Length(1-16)

Trap IP Address:   xxx.xxx.xxx.xxx

You can press "Set" button to apply the settings and "ReGet" button to refresh the setting values.

## 4 NetSetting for Ethernet

### Alert Message Setting

For the alert message notification function, you can decide which error cases need to be sent out to the operator. Moreover, the alert messages can be set to be sent by SMTP, SNMP or both.

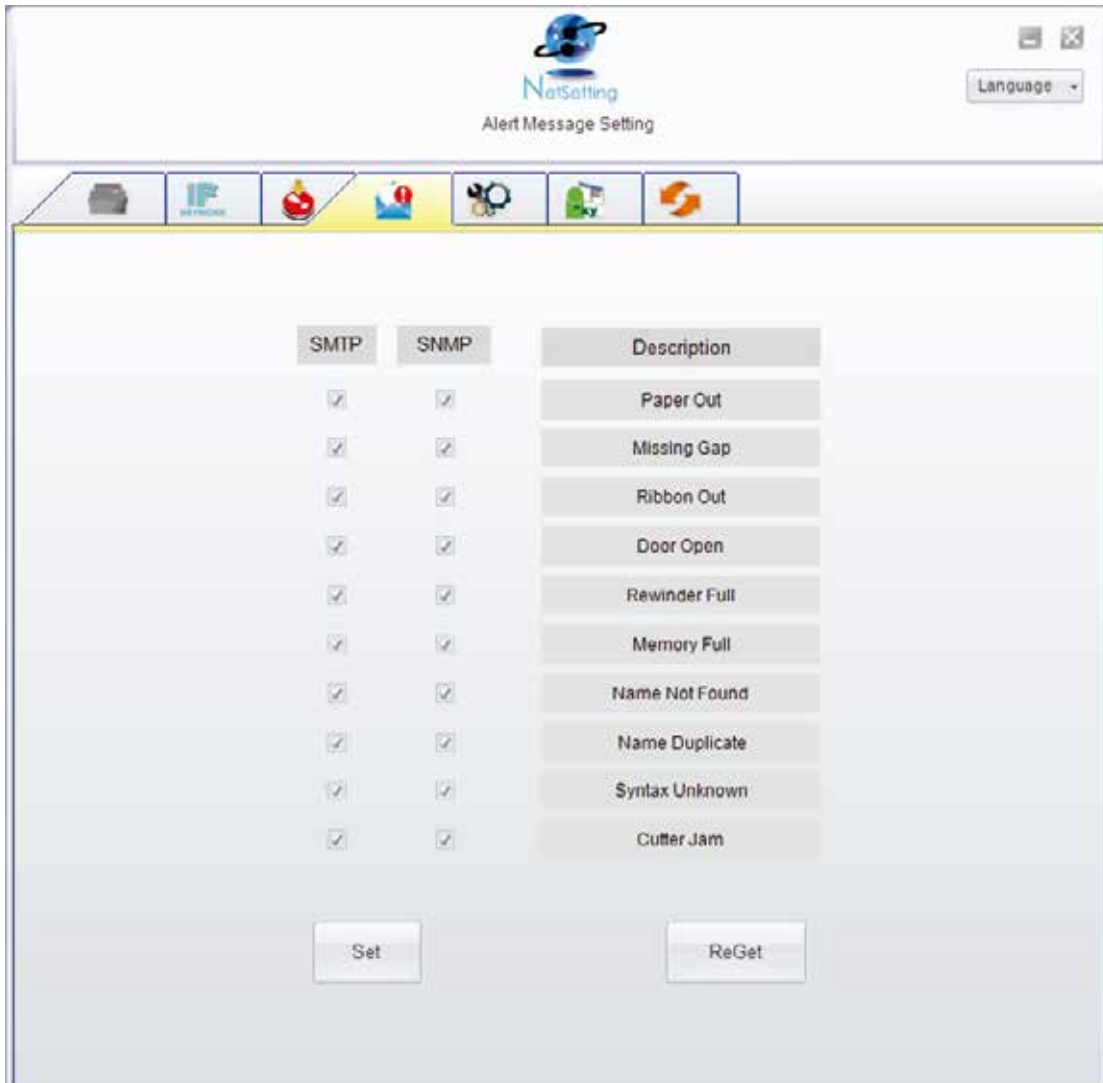

You can press "Set" button to apply the settings and "ReGet" button to refresh the setting values.

# 4 NetSetting for Ethernet

## Printer Configuration

Set or change the configurations of connected printer. Most of key settings for the printer operation can be done by this setting page.

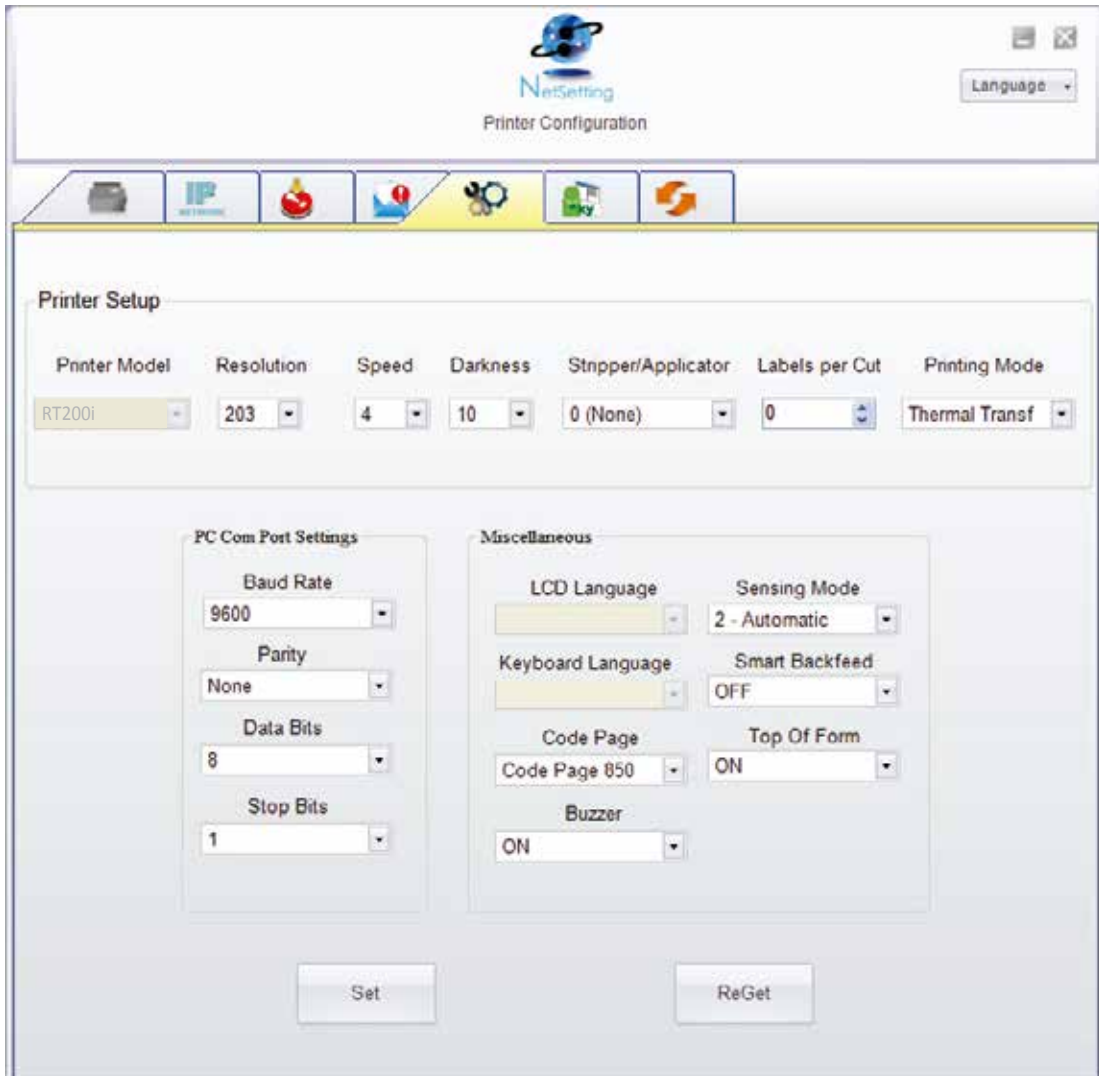

You can press "Set" button to apply the settings and "ReGet" button to refresh the setting values.

## 4 NetSetting for Ethernet

### User Command

The "User Command" tab provides a communication interface for operator to control the printer. Input printer commands in "Input Command" window and press "Send Command" button, the commands will be sent to the printer.

For some commands that will return response message, the message will be displayed in "Output Message" window.

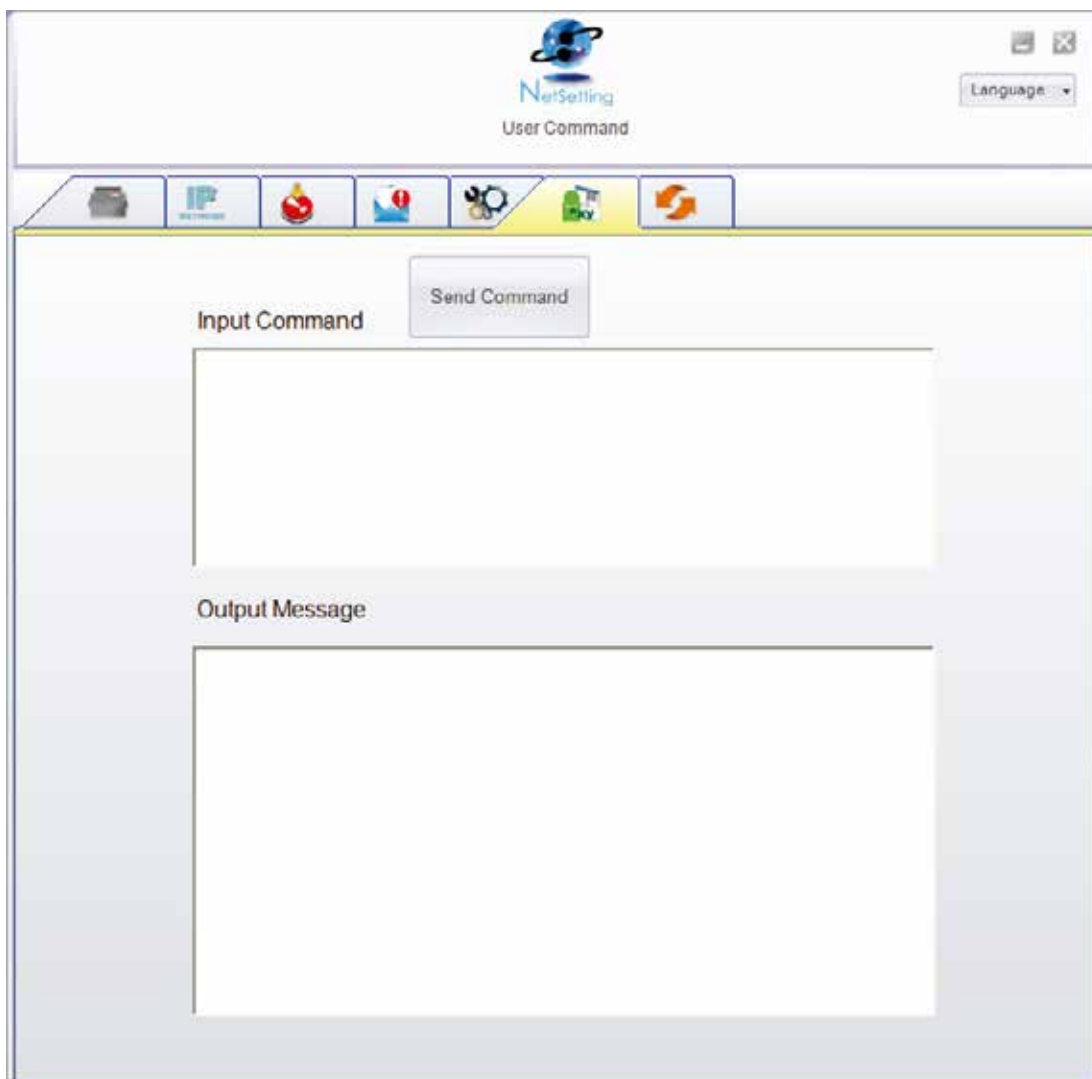

You can press "Send Command" button to send printer commands via Ethernet port and control the printer remotely.

## 4 NetSetting for Ethernet

### Firmware Download

On “Firmware Download” tab, the current version of printer firmware will be showed on the screen. If you need to update the printer firmware, just specify the file location of firmware file and press “Start Download Firmware” button. The printer firmware then can be updated remotely.

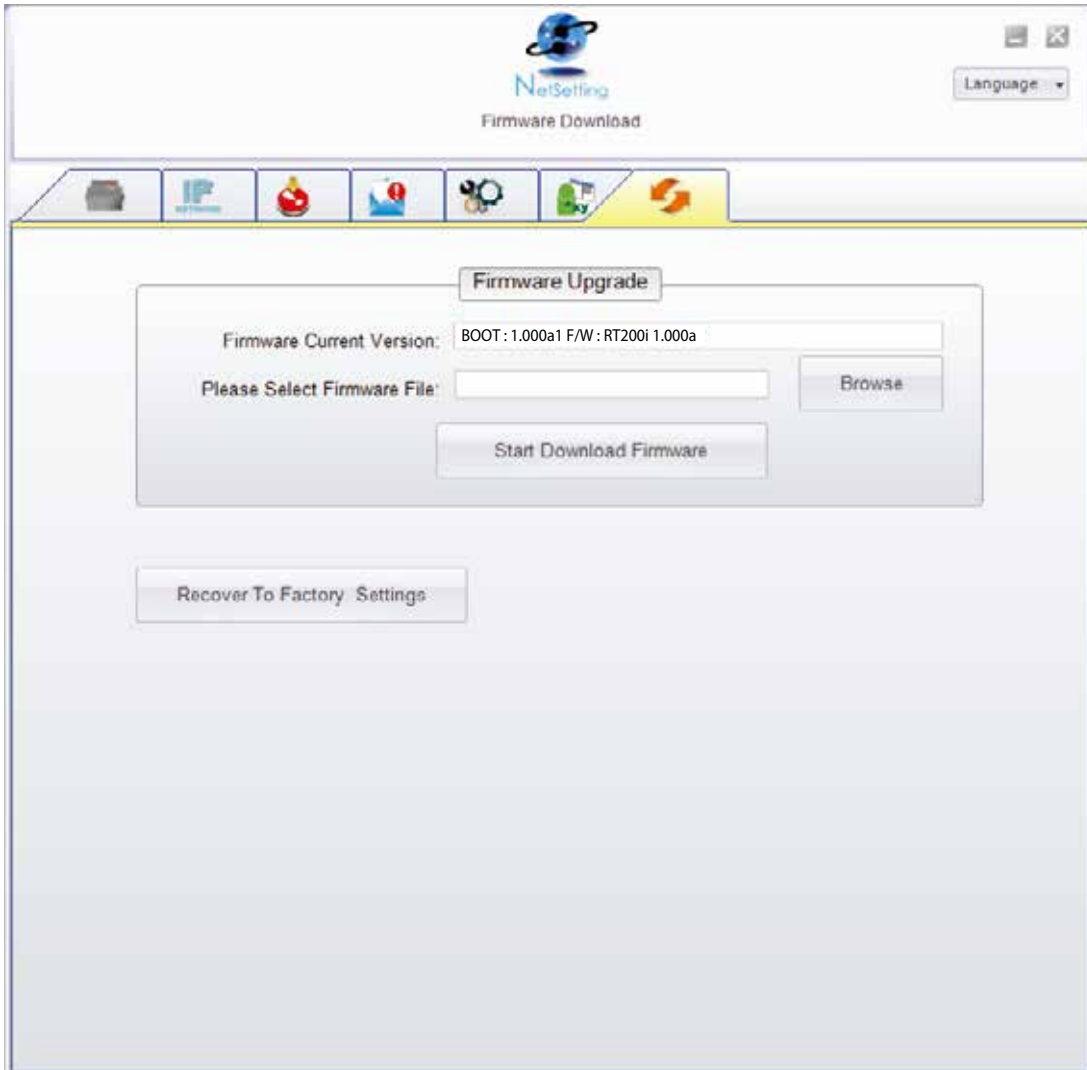

In addition to the firmware update, you can press “Recover To Factory Settings” button to restore the printer configurations back to factory default.

# 5 Accessories

## 5.1 Preparation Steps

Before installing the optional modules, please make some preparations as follows.

1. Turn off the printer  
Remember to switch off the printer before installing any module.
2. Open the printer cover and the printing mechanism  
Open the printer cover by pulling the release catches on both sides of the printer and lift the cover.  
Please see the Section 2.1 for further information about Open The Printer.

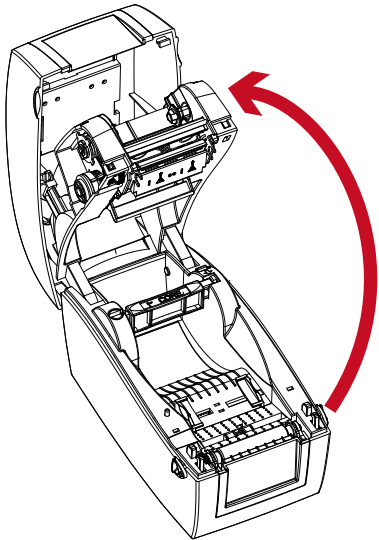

The printing mechanism is lifted up with the printer cover

3. Remove the front cover  
Please pull frontward to remove the front cover.

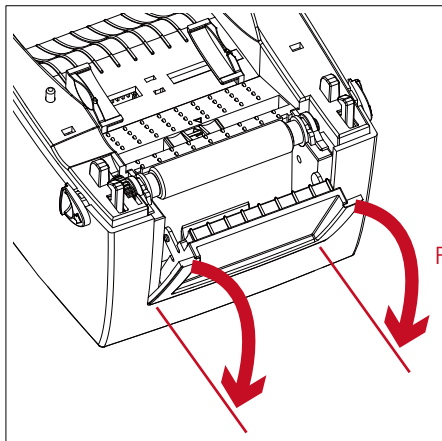

Pull frontward

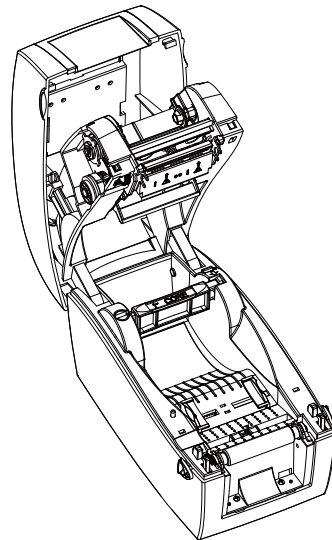



## 5 Accessories

### 4. Remove the platen

Lift up the release clips on both sides of the platen to release and pull upward the platen.

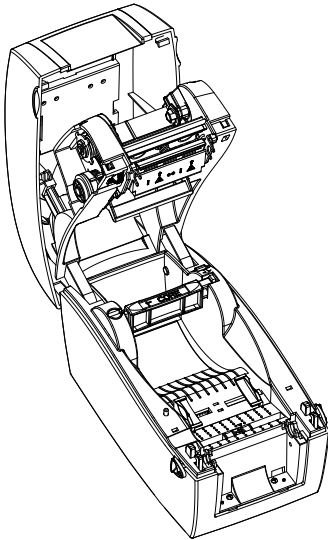
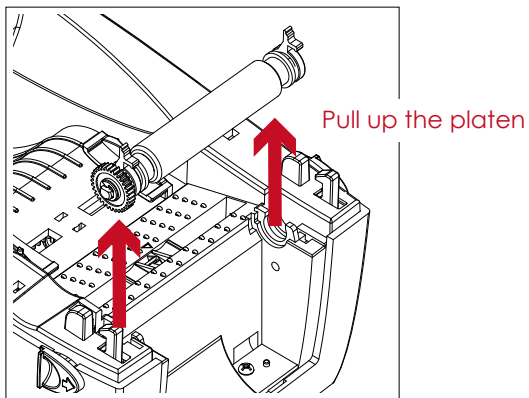
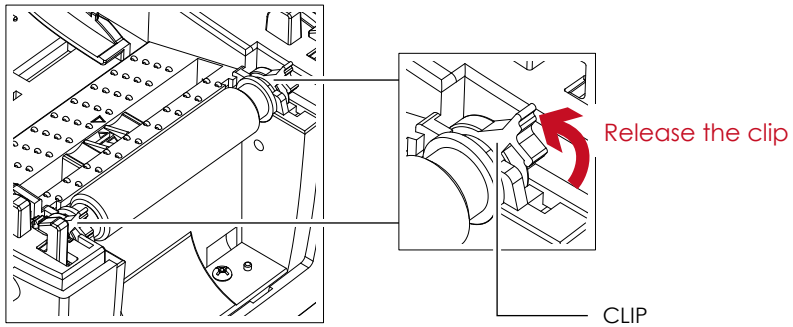

### 5. Ribbon loading

Please see the Section 2.2 for further information about Loading The Ribbon.

### 6. Label loading

Please see the Section 2.3 for further information about Loading The Label Roll Module.

# 5 Accessories

## 5.2 Installing the Label Dispenser

### The Overview of the Label Dispenser

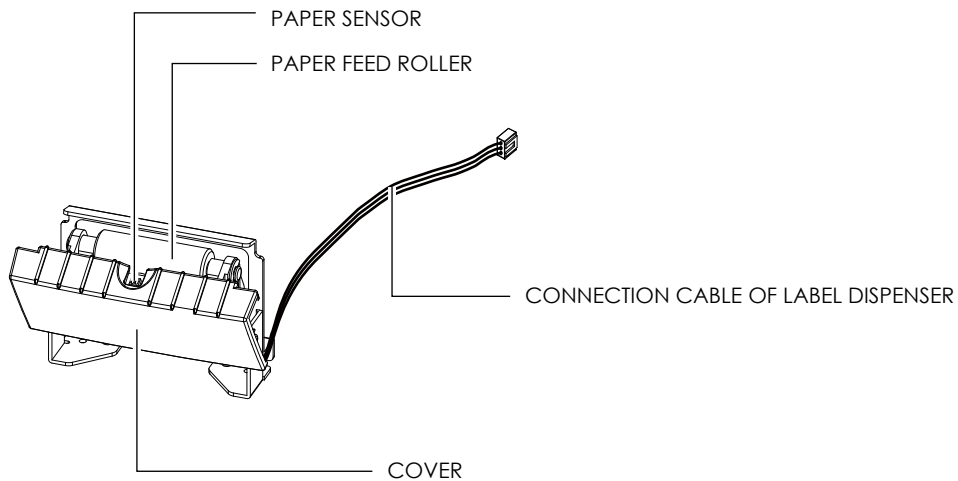

### Preparation Steps

Please see the Section 5.1 Preparation Steps to complete the preparation steps before installing the label dispenser.

### Installing the Label Dispenser

1. Pass the connection cable through the slot of the printer.

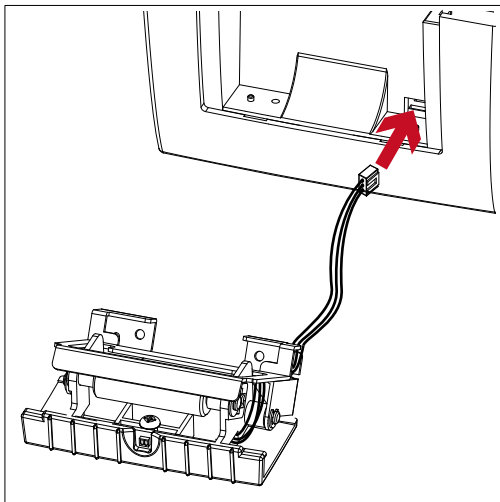

### Notice

- \* A label liner thickness of  $0.006 \text{ mm} \pm 10\%$  and a weight of  $65 \text{ g/m}^2 \pm 6\%$  are recommended.
- \*\* The label dispenser will take labels up to a max. width of 60 mm.
- \*\*\* When using the label dispenser, set the stop position (printer command ^E) to 13.

## 5 Accessories

2. Place label dispenser to align both holes of screw and then tighten the screws.

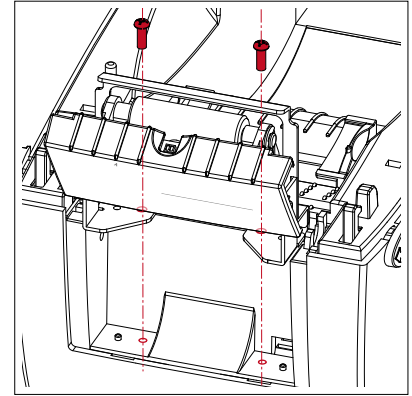
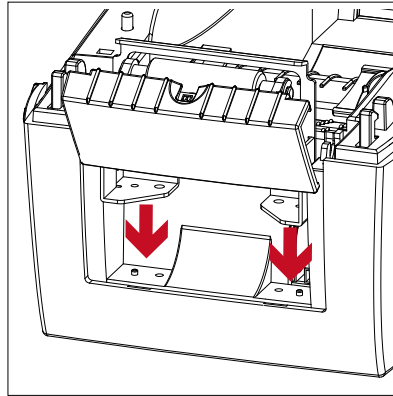
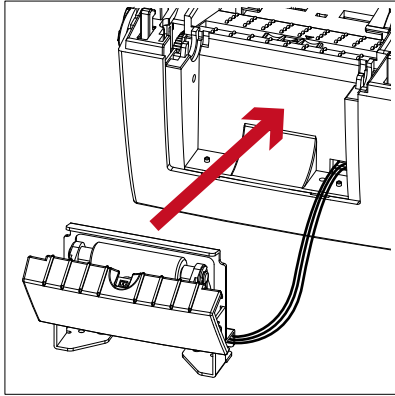

3. Place the platen back to the printer and lock the clips.

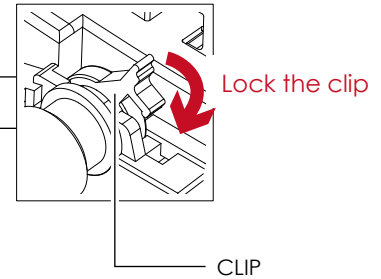
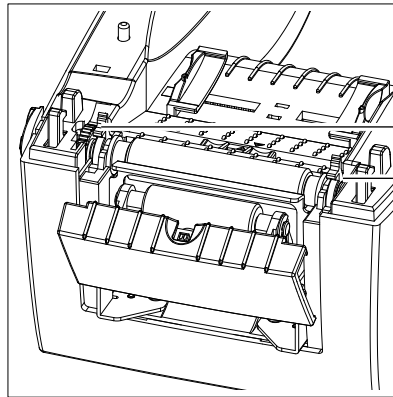
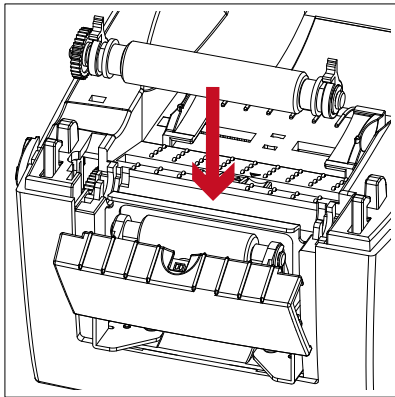

4. Close the top cover and printing mechanism.

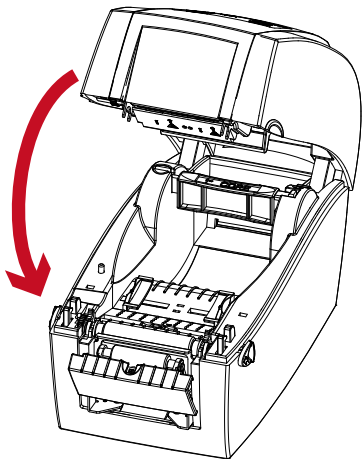

5. Turn the printer upside down.

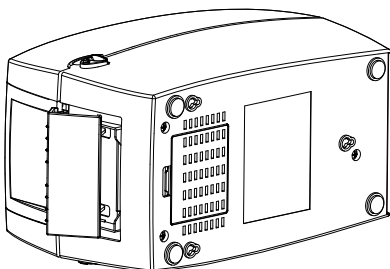

## 5 Accessories

6. Open the cover on the bottom of printer.

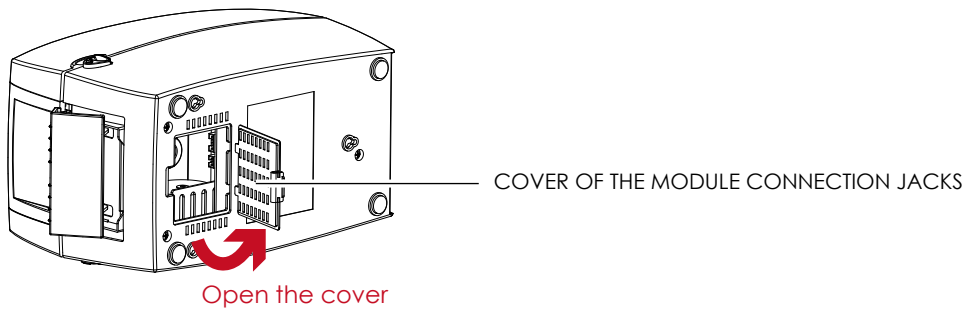

7. Plug the connector for the label dispenser to the jack.

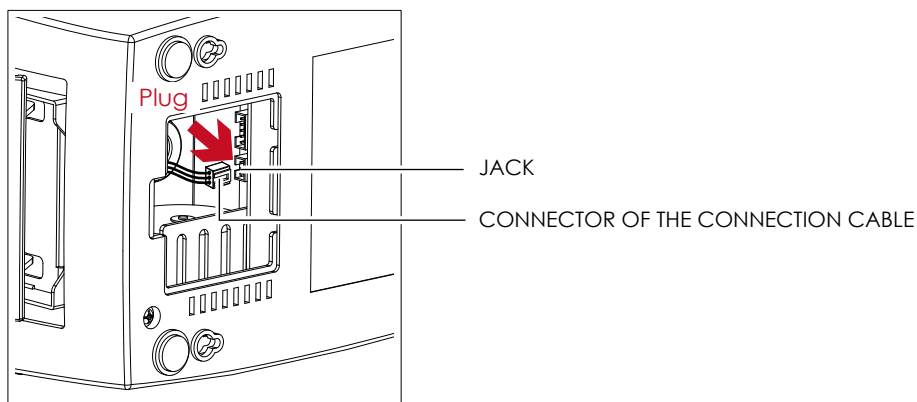

8. Close the cover of the module connection jacks.

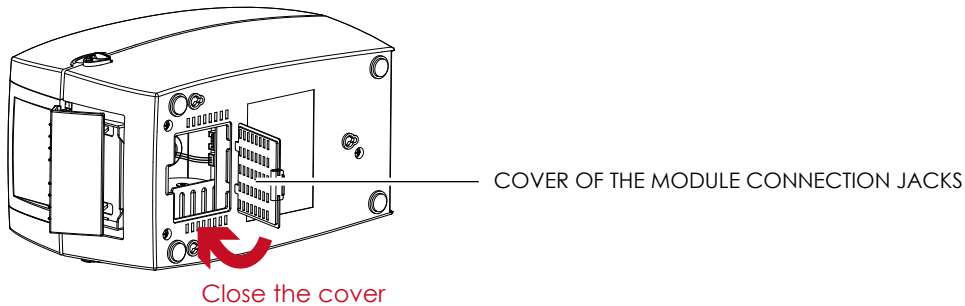

### Notice

- \* The printer must be switched off when plugging the connector, or the motherboard may be destroyed!
- \*\* There are 2 jacks : the lower jack for the label dispenser, the upper jack for the cutter.

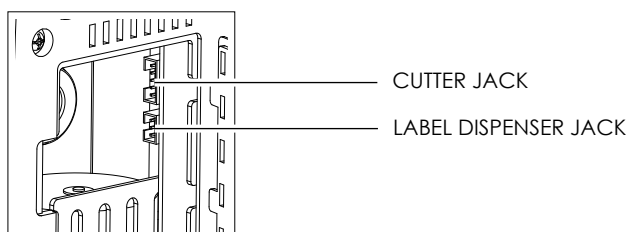

## 5 Accessories

### Loading Label Roll with the Label Dispenser Module

1. Remove the first label from the label stock.

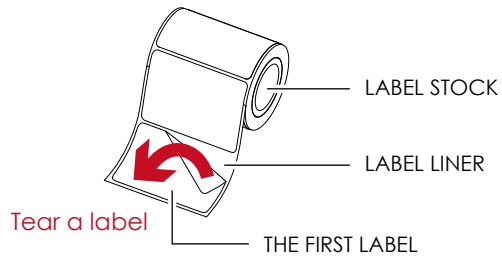

2. Feed the Label stock through the label guides.

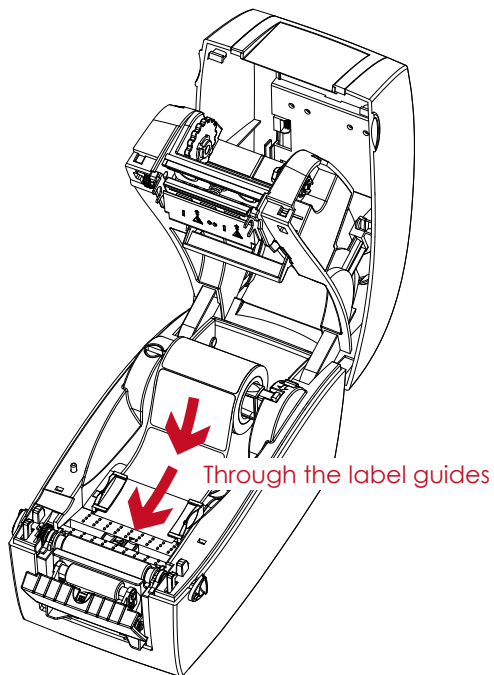

3. Pull the label liner through the platen and the steel of the label dispenser.

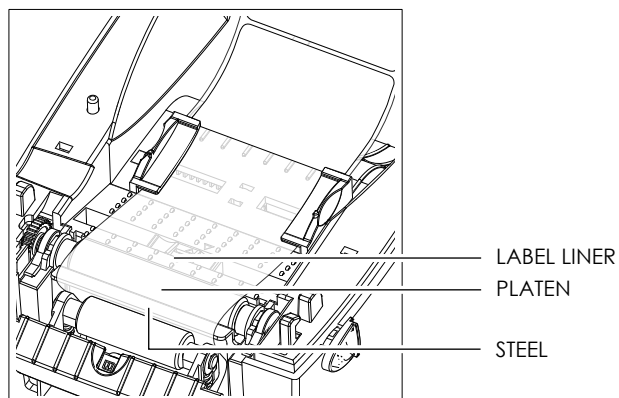

### Notice

- \* Labels should be at least 25 mm high.

## 5 Accessories

4. The feeding path of label and liner should be as shown in below graphic.

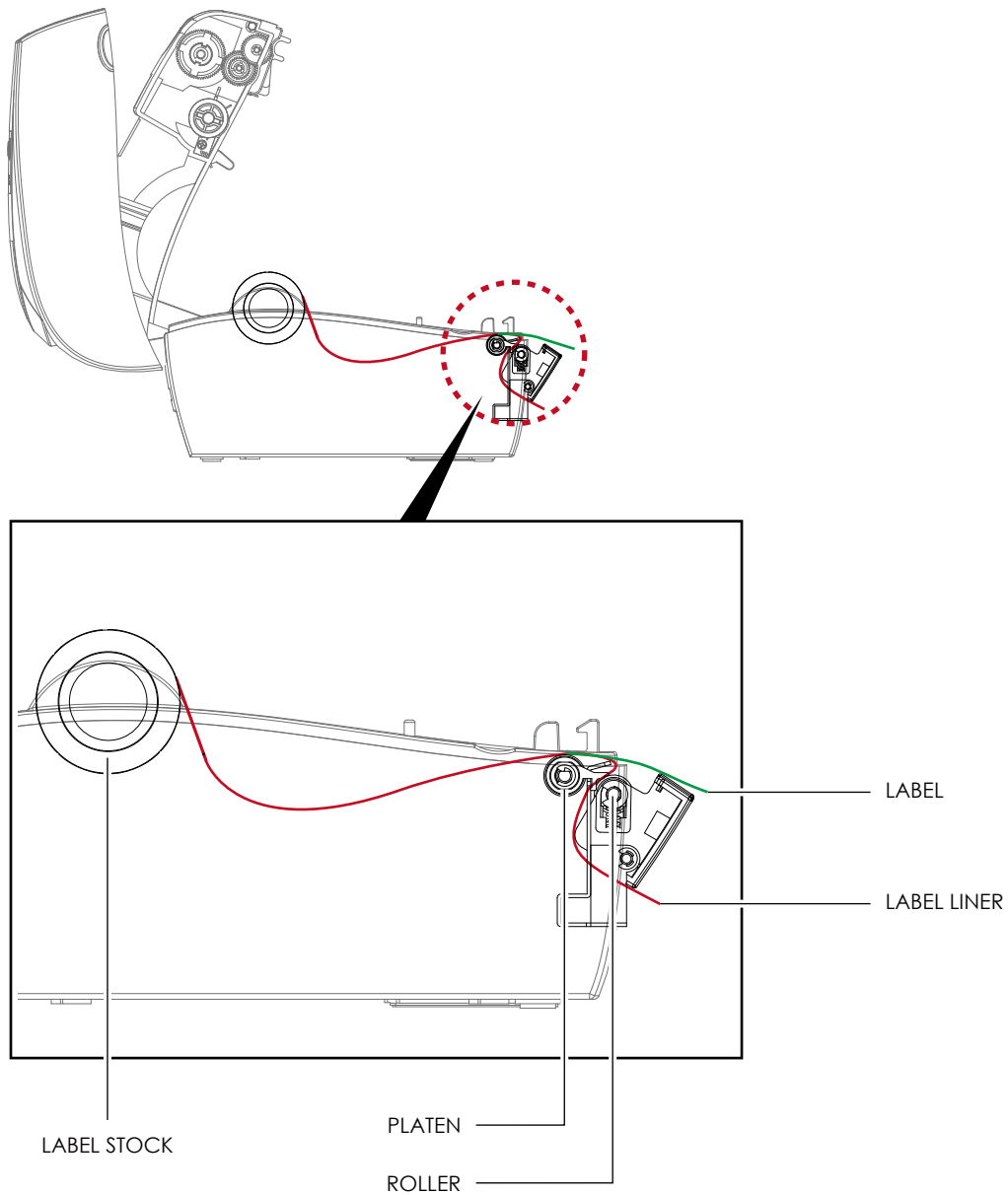

5. Close the label dispenser and printer cover. The installation is completed now.

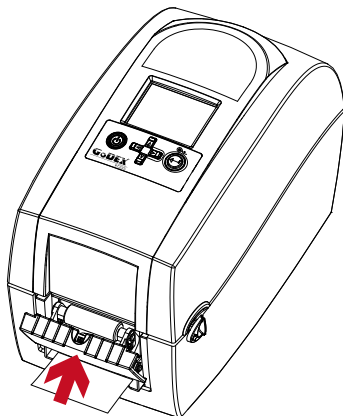

Close the cover

## 5 Accessories

6. Press the FEED button to feed the label. The label will be peeled from the liner while it passes through the label dispenser.

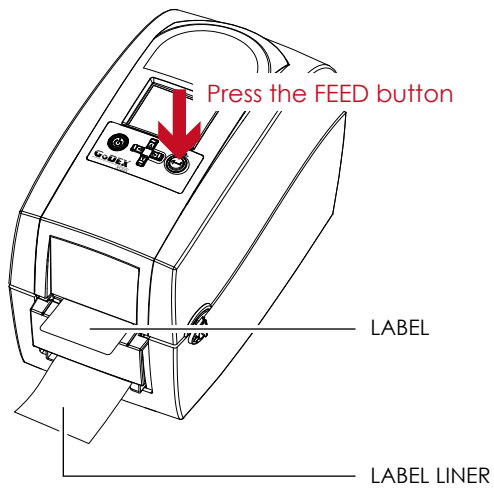

### Notice

- \* There is a paper sensor on the Label Dispenser module. It will stop the printing if it is covered by label. Remove the last printed label and the printer will then continue to print next label.

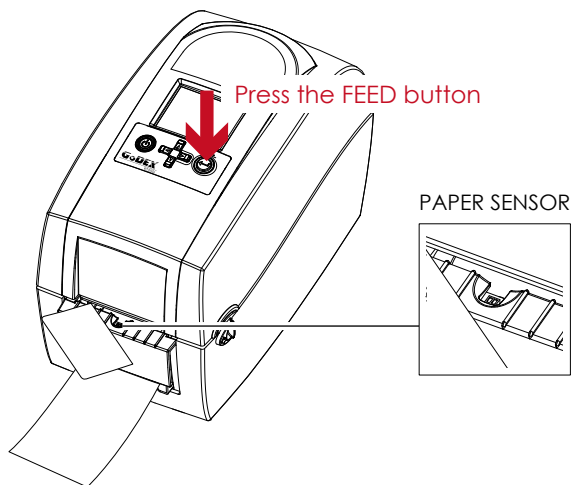

# 5 Accessories

## 5.3 Installing the Cutter

### The Overview of the Cutter

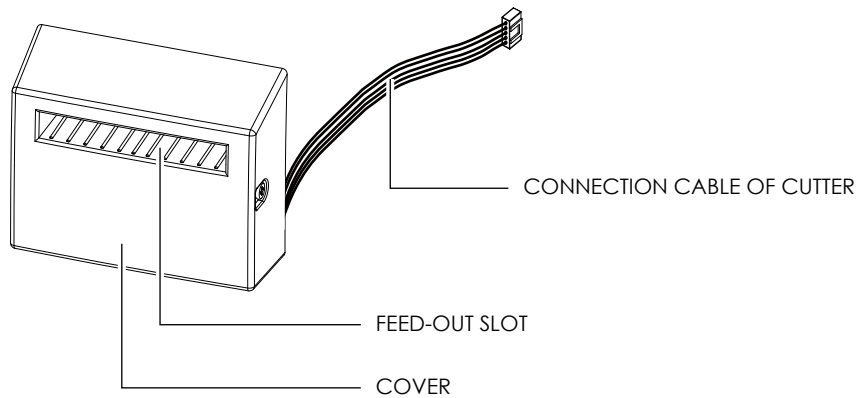

### Preparation Steps

Please see the Section 5.1 Preparation Steps to complete the preparation steps before installing the cutter.

### Installing the Cutter

1. Pass the connection cable through the slot of the printer.

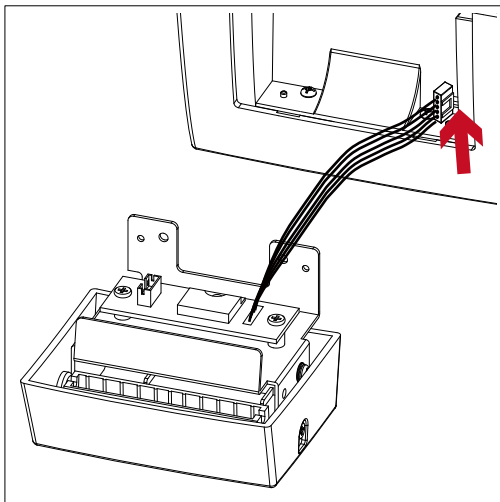

### Notice

- \* Remember to switch off the printer before installing the cutter.
- \*\* Do not use to cut adhesive labels! Glue residue will be left on the cutter blade and impair its functioning. The cutter has a blade life of 1000,000 cuts when using paper weighing 120g/m<sup>2</sup>, and of 500,000 cuts when using paper weighing 120g/m<sup>2</sup> - 170g/m<sup>2</sup>.
- \*\*\* You can cut paper with a max. width of 60mm.
- \*\*\*\*With the cutter installed, set the stop position in Qlabel to 30, and the E value to 30.



## 5 Accessories

2. Place the cutter to align both holes of screw and then tighten the screws.

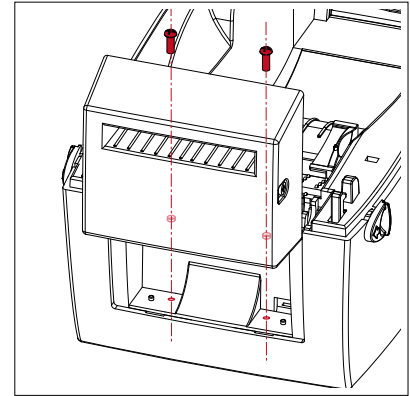
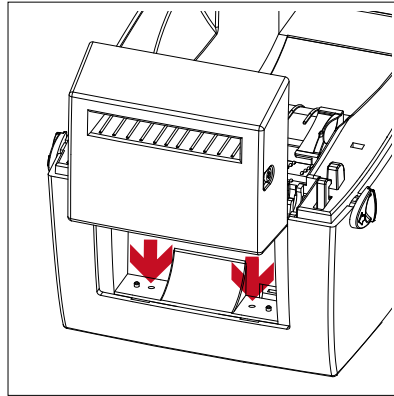
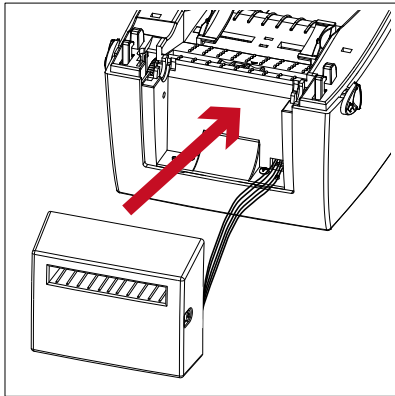

3. Place the platen back to the printer and lock the clips.

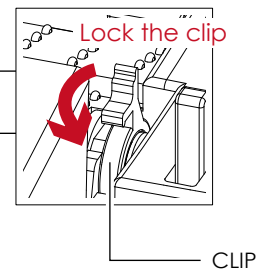
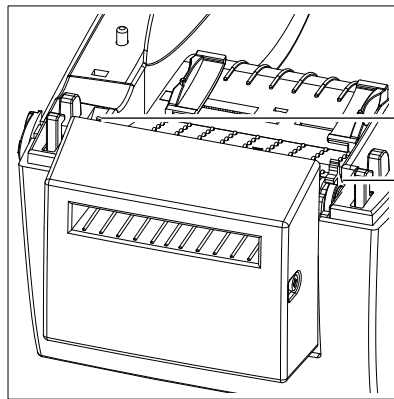
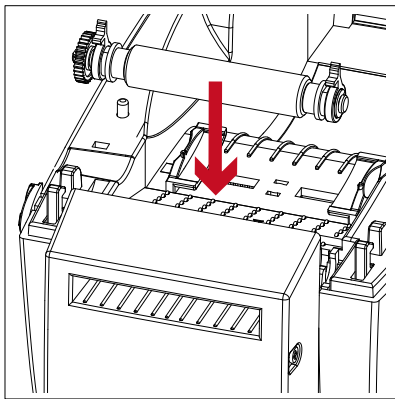

4. Close the top cover and printing mechanism.

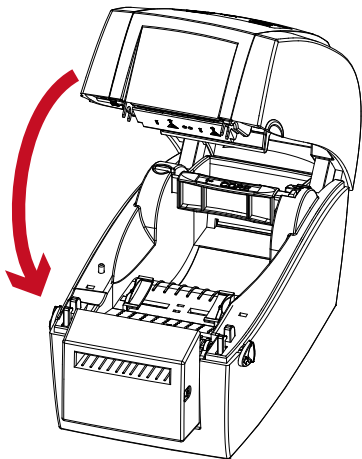

5. Turn the printer upside down.

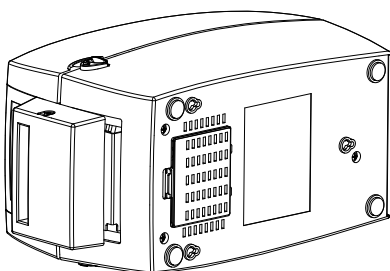

## 5 Accessories

6. Open the cover on the bottom of printer.

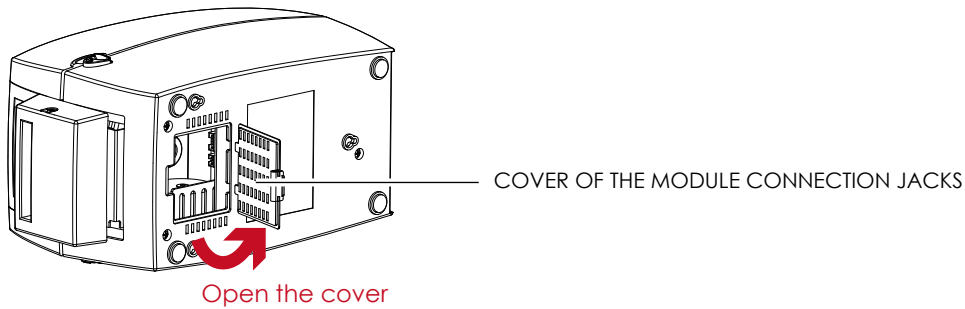

7. Plug the connector for the cutter to the jack.

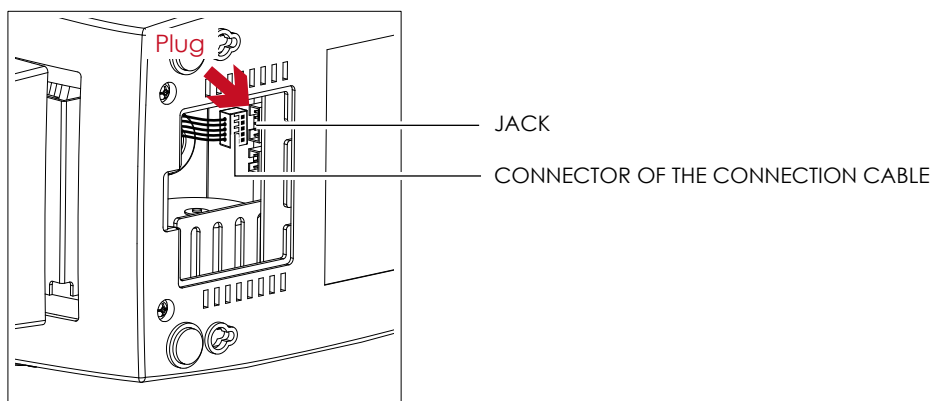

8. Close the cover of the module connection jacks.

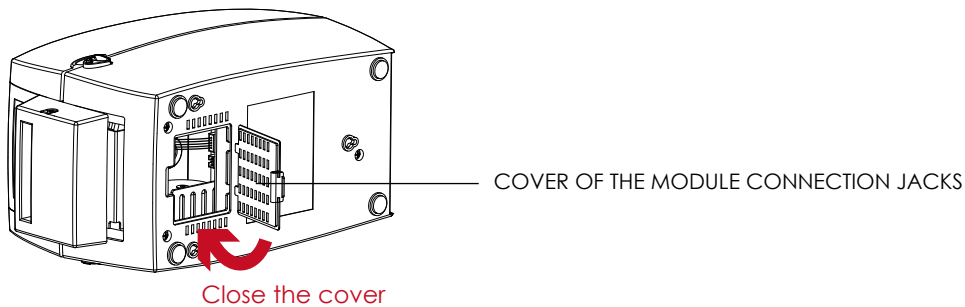

### Notice

- \* The printer must be switched off, or the motherboard may be destroyed!
- \*\* There are 2 jacks : the lower jack for the label dispenser, the upper jack for the cutter.

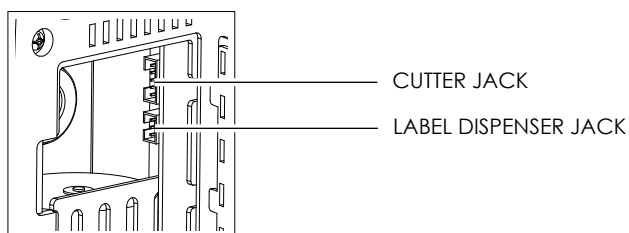

## 5 Accessories

### Installing the Label Roll Module on the Printer

1. Pass the labels through the guides and the cutter.

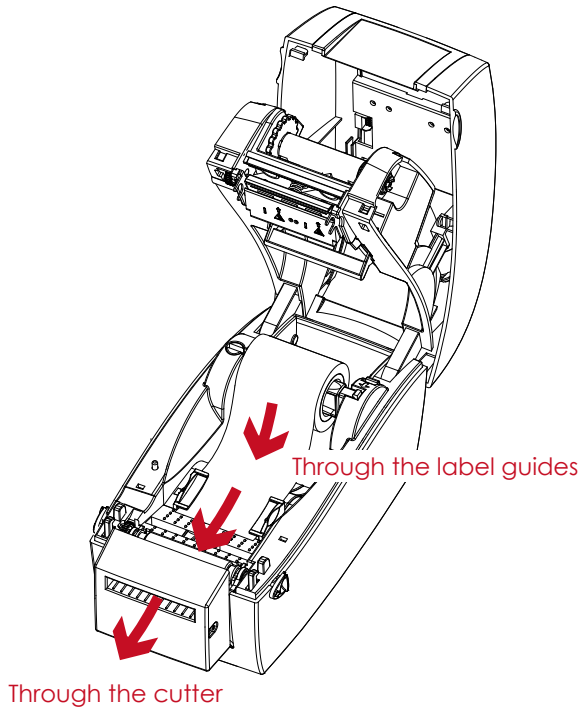

2. Close the top cover and printing mechanism. To finish, press the FEED button to set the label position.

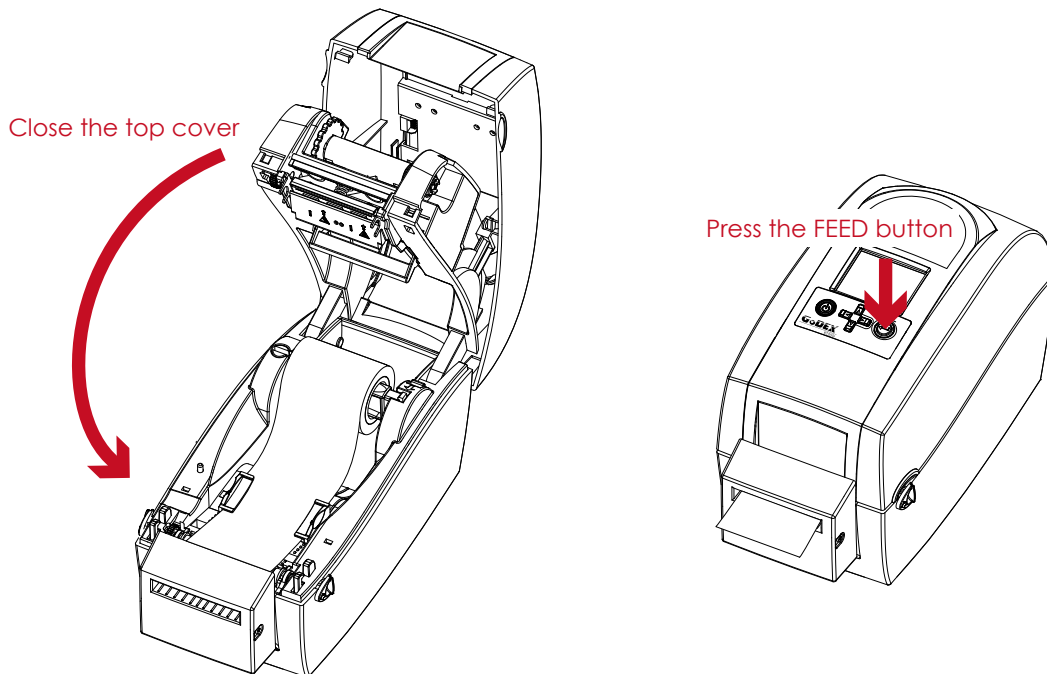

### Notice

- \* We advise against using inside wound label stock.
- \*\* Labels should be at least 30 mm high. When using the printer with the cutter, you should set the stop position (^E) to 30.

## 6 Maintenance and Adjustment

### 6.1 Cleaning the Print Head

Dirt on the print head or ribbon, or glue residue from the label stock may result in inadequate print quality. The printer cover must therefore always be closed during printing. Keeping dirt and dust away from the paper or labels ensures a good print quality and a longer lifespan of the print head.

#### Cleaning Steps

Here is how you clean the print head.

1. Turn off the printer.
2. Open the printer cover.
3. Remove the ribbon.
4. To remove any label residue or other dirt from the print head (see red arrow), please use a soft lint-free cloth dipped in alcohol.

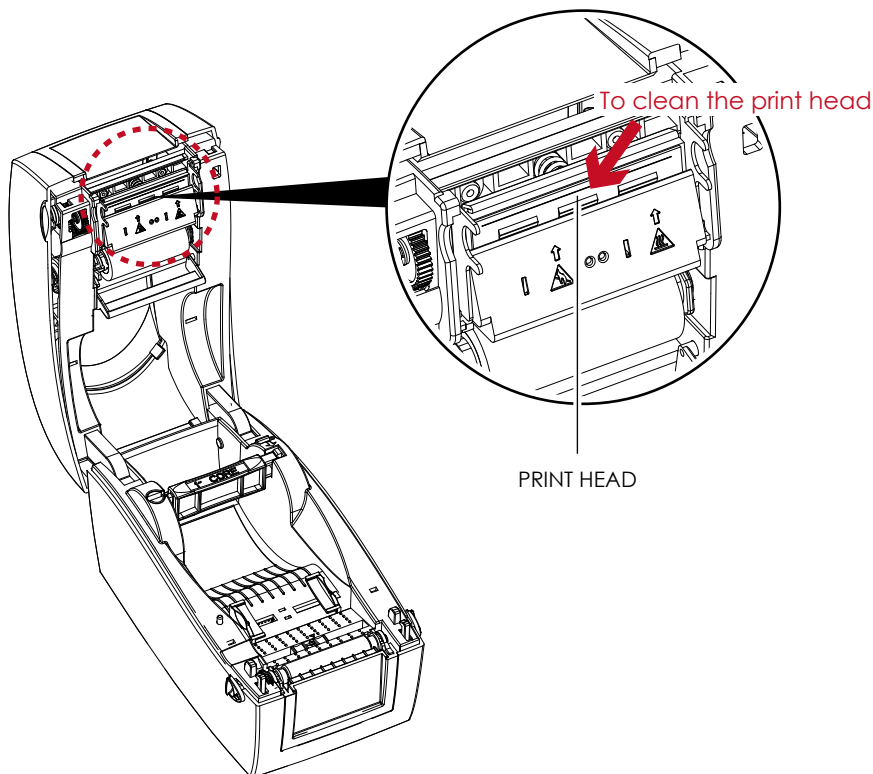

#### Notice

- 
- \* The print head should be cleaned once a week.
  - \*\* Please make sure that there are no metal fragments or other hard particles on the soft cloth used to clean the print head.

# 6 Maintenance and Adjustment

## 6.2 Troubleshooting

Problem	Solution
The printer is switched on but the LCD screen does not light up.	<ul style="list-style-type: none"> <li>◆ Check the power supply.</li> </ul> Please see the Section 2.4
The LCD screen show the notice icon and printing is interrupted.	<ul style="list-style-type: none"> <li>◆ Check the software settings (driver settings) or command codes.</li> <li>◆ Look for the error alert in the table in Section 3.5. Error Alerts.</li> <li>◆ Check whether the print mechanism is closed correctly.</li> </ul> Please see the Section 3.5
The label stock passes through the printer but no image is printed.	<ul style="list-style-type: none"> <li>◆ Please make sure that the label stock is loaded the right way up and that it is suitable material.</li> <li>◆ Choose the correct printer driver.</li> <li>◆ Choose the correct label stock and a suitable printing mode.</li> </ul>
The label stock jams during printing.	<ul style="list-style-type: none"> <li>◆ Clear the paper jam. Remove any label material left on the thermal print head and clean the print head using a soft lint-free cloth dipped in alcohol.</li> </ul> Please see the Section 6.1
There is no printed image on some parts of the label.	<ul style="list-style-type: none"> <li>◆ Check whether any label material or ribbon is stuck to the thermal print head.</li> <li>◆ Check for errors in the application software.</li> <li>◆ Check whether the starting position has been set incorrectly.</li> <li>◆ Check the ribbon for wrinkles.</li> </ul>
There is no printed image on part of the label or the image is blurred.	<ul style="list-style-type: none"> <li>◆ Check the thermal print head for dust or other dirt.</li> <li>◆ Use the internal "~T" command to check whether the thermal print head will carry out a complete print job.</li> <li>◆ Check the quality of the print medium.</li> </ul>
The printed image is positioned incorrectly.	<ul style="list-style-type: none"> <li>◆ Check whether there is paper or dust covering the sensor.</li> <li>◆ Check whether the label stock is suitable. Contact your supplier.</li> <li>◆ Check the paper guide settings.</li> </ul>
A label is missed out during printing.	<ul style="list-style-type: none"> <li>◆ Check the label height setting.</li> <li>◆ Check whether there is dust covering the sensor.</li> <li>◆ Run the auto-detection function.</li> </ul> Please see the Section 3.4
The printed image is blurred.	<ul style="list-style-type: none"> <li>◆ Check the darkness setting.</li> <li>◆ Check the thermal print head for dust or dirt.</li> </ul> Please see the Section 6.1
The cutter does not cut off the labels in a straight line.	<ul style="list-style-type: none"> <li>◆ Check whether the label stock is positioned straight.</li> </ul>
The cutter does not cut off the labels completely.	<ul style="list-style-type: none"> <li>◆ Check whether the label is more than 0.2 mm thick.</li> </ul>
When using the cutter, the labels are not fed through or cut off incorrectly.	<ul style="list-style-type: none"> <li>◆ Check whether the cutter has been correctly installed.</li> <li>◆ Check whether the paper guides are functioning correctly.</li> </ul>
The label dispenser is not functioning normally.	<ul style="list-style-type: none"> <li>◆ Check whether there is dust on the label dispenser.</li> <li>◆ Check whether the label stock is positioned correctly.</li> </ul>

### Notice

\* If any problems occur that are not described here, please contact your dealer.

# APPENDIX

## PRODUCT SPECIFICATIONS

Model	RT200i	RT230i
<b>Print Method</b>	Thermal Transfer / Direct Thermal	
<b>Resolution</b>	203 dpi (8 dots/mm)	300 dpi (12 dots/mm)
<b>Print Speed</b>	7 IPS (177 mm/s)	5 IPS (127 mm/s)
<b>Print Width</b>	2.12" (54 mm)	2.24" (56.9 mm)
<b>Print Length</b>	Min. 0.16" (4 mm)** ; Max. 68" (1727 mm)	Min. 0.16" (4 mm)** ; Max. 30" (762 mm)
<b>Processor</b>	32 Bit RISC CPU	
<b>Memory</b>	<b>Flash</b>	8MB Flash (4MB for user storage)
	<b>SDRAM</b>	16MB SDRAM
<b>Sensor Type</b>	Adjustable reflective sensor (full range). Fixed transmissive sensor, central aligned	
<b>Media</b>	<b>Types</b>	Continuous form, gap labels, black mark sensing, and punched hole; label length set by auto sensing or programming
	<b>Width</b>	0.6" (15 mm) Min. – 2.36" (60 mm) Max.
	<b>Thickness</b>	0.003" (0.06 mm) Min. - 0.008" (0.2 mm) Max.
	<b>Label roll diameter</b>	Max. 5" (127 mm)
	<b>Core diameter</b>	1", 1.5" (25.4 mm, 38.1 mm)
<b>Ribbon</b>	<b>Types</b>	Wax, wax/resin, resin
	<b>Ribbon roll diameter</b>	1.5" (38 mm) Max.
	<b>Core diameter</b>	0.5" (12.7 mm)
	<b>Length</b>	360' (110 m)
	<b>Width</b>	2.20" (56mm) – 2.32" (59mm)
<b>Printer Language</b>	EZPL, GEPL, GZPL auto switch	
<b>Software</b>	<b>Label design software</b>	GoLabel (for EZPL only)
	<b>Driver</b>	Windows 2000, XP, Vista, 7, Windows Server 2003 & 2008
	<b>DLL</b>	Windows 2000, XP, Vista
<b>Resident Fonts</b>	<b>Bitmap fonts</b>	6, 8, 10, 12, 14, 18, 24, 30, 16X26 and OCR A & B Bitmap fonts 90°, 180°, 270° rotatable, single characters 90°, 180°, 270° rotatable Bitmap fonts 8 times expandable in horizontal and vertical directions
	<b>Scalable fonts</b>	90°, 180°, 270° rotatable
<b>Download Fonts</b>	<b>Bitmap fonts</b>	Bitmap fonts 90°, 180°, 270° rotatable, single characters 90°, 180°, 270° rotatable
	<b>Asian fonts</b>	Asian fonts 90°, 180°, 270° rotatable and 8 times expandable in horizontal and vertical directions
	<b>Scalable fonts</b>	Scalable fonts 90°, 180°, 270° rotatable
<b>Barcodes</b>	<b>1-D Bar codes</b>	Code 39, Code 93, EAN 8 /13 (add on 2 & 5), UPC A/E (add on 2 & 5), I 2 of 5 & I 2 of 5 with Shipping Bearer Bars, Codabar, Code 128 (subset A, B, C), EAN 128, RPS 128, UCC 128, UCC/EAN-128 K-Mart, Random Weight, Post NET, ITF 14, China Postal Code, HIBC, MSI, Plessey, Telepen, FIM, GS1 DataBar
	<b>2-D Bar codes</b>	PDF417, Datamatrix code, MaxiCode, QR code, Micro PDF417, Micro QR code and Aztec code
<b>Code Pages</b>	CODEPAGE 437, 850, 851, 852, 855, 857, 860, 861, 862, 863, 865, 866, 869, 737 WINDOWS 1250, 1251, 1252, 1253, 1254, 1255, 1257 Unicode (UTF8, UTF16)	
<b>Graphics</b>	Resident graphic file types are BMP and PCX, other graphic formats are downloadable from the software	

# APPENDIX

## PRODUCT SPECIFICATIONS

Model	RT200i	RT230i	
<b>Interfaces</b>	USB Device (B-Type)	USB Device (B-Type)	USB Device (B-Type)
	Serial port: RS-232 (DB-9)	Serial port: RS-232 (DB-9)	Serial port: RS-232 (DB-9)
	USB Host (A-Type)	USB Host (A-Type)	USB Host (A-Type)
	IEEE 802.3 10/100Base-Tx	IEEE 802.3 10/100Base-Tx	IEEE 802.3 10/100Base-Tx
	Ethernet port (RJ-45)	Ethernet port (RJ-45)	Ethernet port (RJ-45)
<b>Control Panel</b>	Color TFT LCD with navigation button		
	Calibration button		
	Power on/off button		
<b>Real Time Clock</b>	Standard		
<b>Power</b>	Auto Switching 100-240VAC, 50-60Hz		
<b>Environment</b>	<b>Operation temperature</b>	41°F to 104°F (5°C to 40°C)	
	<b>Storage temperature</b>	-4°F to 122°F (-20°C to 50°C)	
<b>Humidity</b>	<b>Operation</b>	30-85%, non-condensing.	
	<b>Storage</b>	10-90%, non-condensing.	
<b>Agency Approvals</b>	CE(EMC), FCC Class A, CB, CCC, cUL		
<b>Dimension</b>	Length	9.7" (245 mm)	
	Height	6.9" (175 mm)	
	Width	5.3" (136mm)	
<b>Weight</b>	4.4 lbs (2.0Kg), excluding consumables		
<b>Options</b>	Guillotine Cutter		
	Label Dispenser		
	External label roll holder for 10" (250 mm) O.D. label rolls		
	External label rewinder		

### Notice

\* Specifications are subject to change without notice. All company and/or product names are trademarks and/or trademarks of their respective owners.

\*\* Minimum print height and maximum print speed specification compliance can be dependent on non-standard material variables such as label type, thickness, spacing, liner construction, etc. Godex is pleased to test non-standard materials for minimum print height and maximum print speed capability.

# APPENDIX

## INTERFACE

---

### Pinout Description

- USB

Connector Type : Type B

Pin NO.	1	2	3	4
Function	VBUS	D-	D+	GND

- Serial Port

Default settings : Baud rate 9600, no parity, 8 data bits, 1 stop bit, XON/XOFF protocol and RTS/CTS

RS232 Housing(9-pin to 9-pin)		
DB9 Socket		DB9 Plug
-	1	+5V, max 500mA
RXD	2	TXD
TXD	3	RXD
DTR	4	N/C
GND	5	GND
DSR	6	RTS
RTS	7	CTS
CTS	8	RTS
RI	9	N/C
Computer		Printer

### Notice

---

- \* The total current to the serial port may not exceed 500mA.



# APPENDIX

## FILE MANIPULATION WHEN USING USB STICK

### File Manipulation

The files in both devices (USB memory stick and printer internal Flash memory) are able to copy and move by the commands ‘‘~MCPY’’ and ‘‘MMOV’’ that sends from GoLabel on a PC via either connection - USB or Ethernet ports.

- Copy

Syntax	~MCPY,s:o.x,d:o.x
Description	Copy file from USB memory stick to Flash memory, or vise-versa
Parameter	<p>s = source device of stored object;</p> <ul style="list-style-type: none"> <li>● “D” for USB memory stick; “F” for internal Flash memory</li> </ul> <p>d = destination device of stored object</p> <ul style="list-style-type: none"> <li>● “D” for USB memory stick; “F” for internal Flash memory</li> </ul> <p>o = object name (file name); the name “o” is substituted for “*”</p> <p>x = extension (file type), the type “x” is substituted by “*”, or following either one: D= database, A= Asia font, C= TTF font, E= Bit-Mapped font, F= label format, G= graphic, S= serial file, T= text, B= Unicode Table.</p>
Example	<p>~MCPY,F:*.F,D:*.F (Copy entire “Label Format” files from Flash memory to USB memory stick)</p> <p>~MCPY,D:*.G,F:*.G (Copy entire “Graphic” files from USB memory stick to Flash Memory)</p> <p>~MCPY,D:*.*,F:*. * (Copy all object files from USB memory stick to Flash Memory)</p>

- Move

Syntax	~MMOV,s:o.x,d:o.x
Description	Move files from USB memory stick to Flash memory or vise-versa
Parameter	<p>s = source device of stored object;</p> <ul style="list-style-type: none"> <li>● “D” for USB memory stick; “F” for internal Flash memory</li> </ul> <p>d = destination device of stored object</p> <ul style="list-style-type: none"> <li>● “D” for USB memory stick; “F” for internal Flash memory</li> </ul> <p>o = object name (file name); the name “o” is substituted for “*”</p> <p>x = extension (file type), the type “x” is substituted by “*”, or following either one: D= database, A= Asia font, C= TTF font, E= Bit-Mapped font, F= label format, G= graphic, S= serial file, T= text, B= Unicode Table.</p>
Example	<p>~MMOV,F:*.F,D:*.F (Move entire “Label Format” files from Flash memory to USB memory stick)</p> <p>~MMOV,D:*.G,F:*.G (Move entire “Graphic” files from USB memory stick to Flash Memory)</p> <p>~MMOV,D:*.*,F:*. * (Move all object files from USB memory stick to Flash Memory)</p>