

Quick Start Guide

Easy steps to getting started

1 **Unpack Contents**

Unpack your digitizer package and check for major components.

1. Medi-6000 Plus
2. Output Basket
3. Feed Tray
4. Output Guide
5. Power Cord
6. Software CD
7. Hi-Speed USB Cable

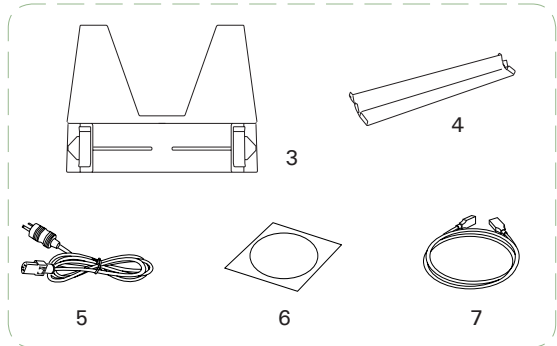
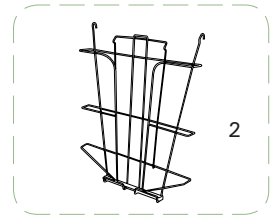
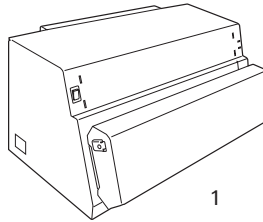

2 **Install Software**

Important: You must install software before connecting your digitizer. Always close any open programs and turn off Anti-virus utilities before installing software.

- A. Turn on your computer.
- B. Place the Microtek CD-ROM into the CD-ROM drive, and follow the on-screen instructions to install the driver and software.
- C. Restart your computer at the end of installation.

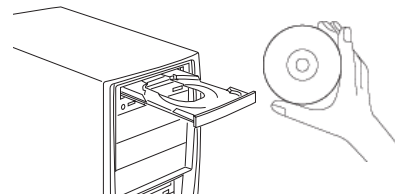

NOTE: If the Software Installer screen does not come up automatically, double-click the following in succession: "My Computer"; the CD-ROM icon; then cdsetup.exe to start the installer program.

3

Install Digitizer**Install Feed Tray**

- A. Look for two sets of the Feed Tray Holes at both ends of the front-top of the digitizer.
- B. Insert and push down both sides of the Feed Tray into its compartment holes, making sure the Feed Tray snaps into place.

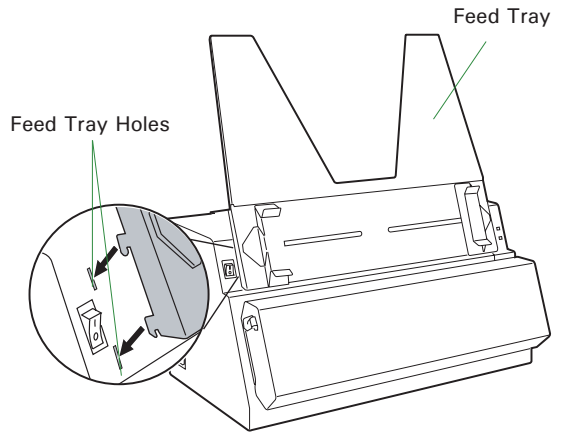
**Install either Output Guide or Output Basket**

- A. Look for two sets of Output Tray Holes at both ends of the front-bottom of the digitizer.
 - B. Insert and push down both sides of the Output Guide into its compartment holes, making sure the Output Guide snaps into place.
- Or, Insert and push down both sides of the Output Basket into its compartment holes, making sure the Output Basket snaps into place.

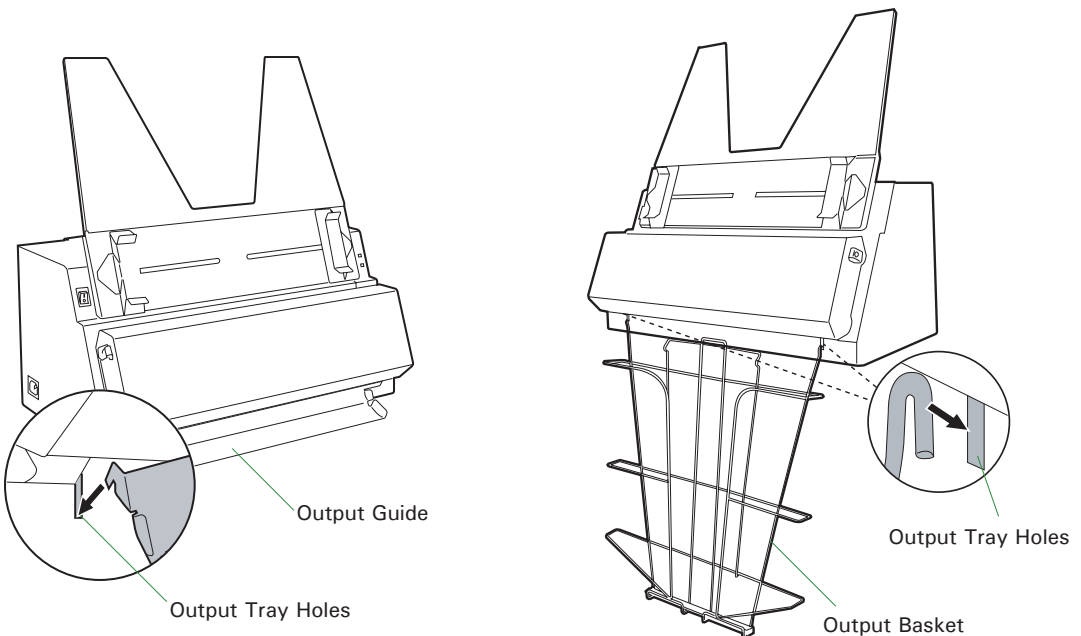

4

Connect Digitizer

To the power cord

- A. Connect the power cord to the left side of the digitizer.
- B. Plug one end of the power cord into a wall outlet or other power source.

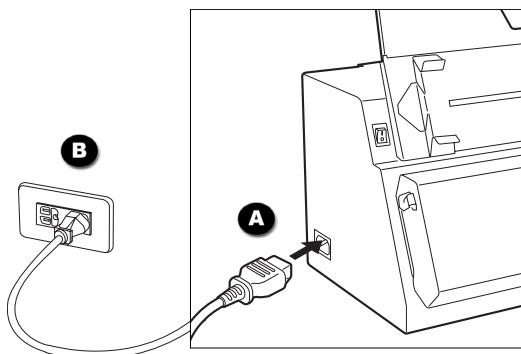

To the Hi-Speed USB cable

- C. Connect one end of the Hi-Speed USB cable to your computer.
- D. Connect the other end of the Hi-Speed cable to the digitizer's USB port, locating at the left side of the digitizer.

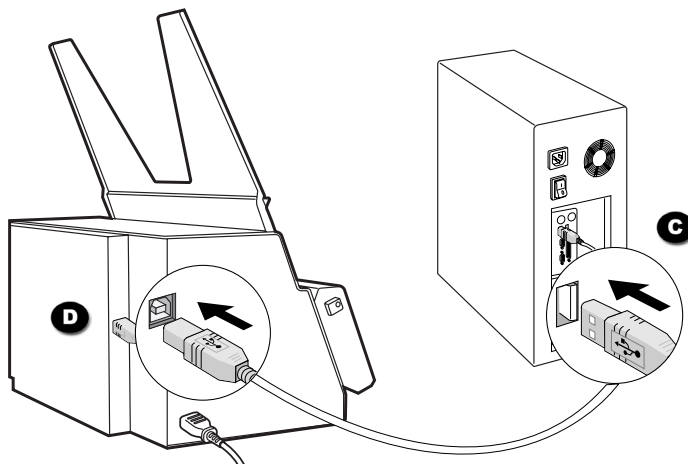

- E. Turn the power switch at the front-left panel of the digitizer to "On"; once the scanner is detected by your system, the LED lights on the front panel will brighten, and the digitizer is ready to scan.

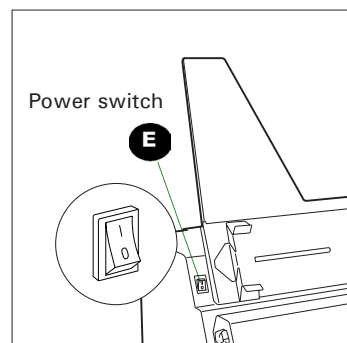

Scanning Basics

Warning: Do not place more than one piece of X-ray film into the Feed Tray, for doing so will damage the original film during the feeding process.

1. Launch ScanWizard Medi

To launch ScanWizard Medi as a stand-alone program, double-click the ScanWizard Medi icon on your desktop.

After ScanWizard Medi is started up the first time, the Preview and Settings windows appear on the screen automatically.



2. Load and Scan X-ray film

Load and insert the X-ray film into the Feed Tray, with the side to be scanned facing up and with the top end of the film directing upwardly.

Push the X-ray film into the tray until the edge of it touches the bottom edge of the Feed Tray.

Once the film is detected by the digitizer, the ScanWizard Medi will automatically recognize, auto-crop, and perform a scan of the film and save it in your preferred folder or application.

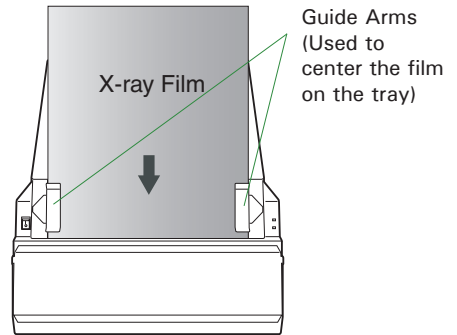

3. View the Image

Double-click the "MSmart Images" icon on the desktop to view the images.

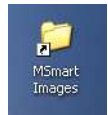

NOTE: Your scan job can be carried out automatically with your own scanning settings. For details on how to customize your scanning settings, refer to the Medi-6000 Plus User's Manual.

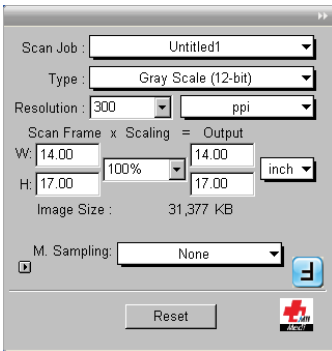

Settings window

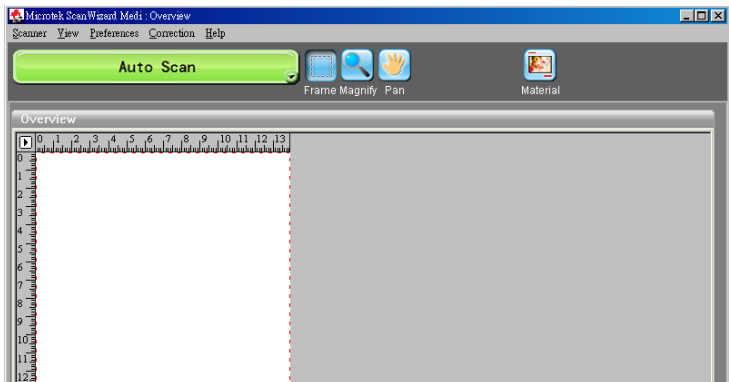

Preview window

Fixing Film Jams

1. Open the front cover by pressing the Release buttons on the both sides of the front cover.

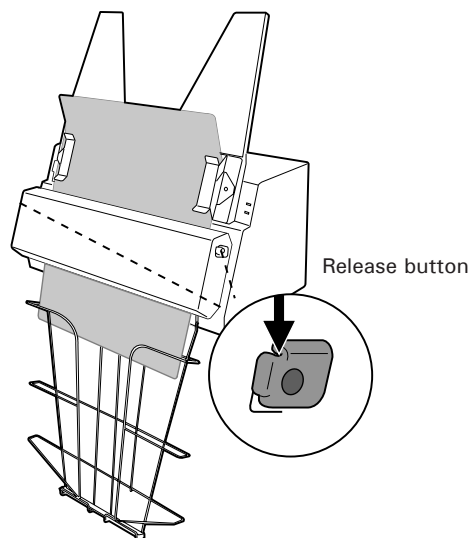



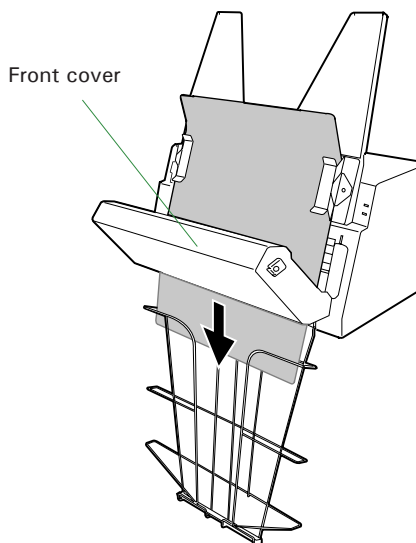





2. After opening the front cover, let the jammed film fall into the Output Basket and then remove it from the Output Basket.



NOTE: To remove the jammed film from the digitizer, you have to open the front cover first. Otherwise, your film may be damaged if they are forcedly removed.

Problems?

The LEDs on the front right panel of the digitizer indicate the status of the digitizer.

		All Off - Digitizer is off
		Flashing Orange - Warming up or starting up the scanning
		Orange off - Scanning
		All On - Ready to scan

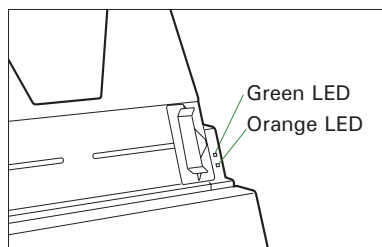

First, make sure that you have followed installation steps as described in this guide. Then if your problem is listed here, try the suggested solution.

1. No light comes on when the digitizer is turned on.

Make sure your digitizer is connected to your computer and plugged into a power source.

2. The Add/Remove Hardware Wizard appears on your screen.

Click the "Cancel" button and close the ScanWizard Medi software. Disconnect the Hi-Speed USB cable from your computer, and refer to the installation instructions in this guide.

3. When trying to scan, an error message appears on your screen that reads, "Can't Find Scanners".

Make sure your digitizer is connected to your computer and plugged in to a power source (see Step 4).

Uninstall and reinstall the ScanWizard Medi software.

4. After clicking "Scan," a blank screen appears.

Uninstall and reinstall the ScanWizard Medi software.

5. When trying to scan, an error message appears on your screen that reads, "Code -204, Scanning lamp or image sensor circuit failure. Please don't select fast preview or draft scan!"

This error message appears when the luminance of lamps is insufficient or surpassed.

Click OK first; then contact the professional technician or call the Microtek Customer Service Department for the further help.

Do You Need Assistance?

Manuals

If you have additional questions and need further instruction or information, we provide electronic manuals for:

1. Using your Medi-6000 Plus
2. Using the ScanWizard Medi scanning software

To access the electronic manuals: Insert the Medi-6000 Plus CD-ROM into your computer's CD-ROM drive. Next, locate and click the "Manuals" option when the software installer window appears on your screen. Finally, select and click the title of the manual you wish to view.

Missing Items

If your package is missing items, please call the Microtek Customer Service Department.

Drivers & Software Upgrades

After you finish the installation of software, if you found that the installed drivers and software cannot run your product or your computer system properly later, please go to the Microtek Download Service site at www.microtek.com/service.php to download and install any updates you may require.

For additional information about Microtek products, please visit our website at www.microtek.com.



Microtek International, Inc.
No. 6, Industry East Road 3,
Science-Based Industrial Park,
Hsinchu, Taiwan



Huaguang (Germany) GmbH
Linsellesstraße 127,
47877 Willich, Germany

Copyright © 2019 Microtek International, Inc. The following are trademarks or registered trademarks of their respective companies: Microtek, ScanMaker, ScanWizard of Microtek International, Inc. All other trademarks or registered trademarks are the property of their respective holders. Specifications, software and hardware bundles are subject to change without notice. Delivery of technical support services subject to change without notice. Not responsible for typographical errors.

MICROTEK

