



AR-24 User Manual



<http://www.GCCworld.com>

NOTICE

GCC reserves the right to modify the information contained in this user manual at any time without prior notice; un-authorized modification, copying distribution or display is prohibited. All comments, queries or suggestions concerning this manual please consult with your local dealer.

Important Information

Thank you for purchasing the **AR-24 Cutting Plotter**.

Before you use the cutting plotter, please make sure that you have read the safety precautions and instructions below.



Caution

SAFETY PRECAUTIONS!

For safety concern, please always hold the cutter firmly **from the bottom** while moving it. Do not move the cutter by clasping the depression area on both sides.

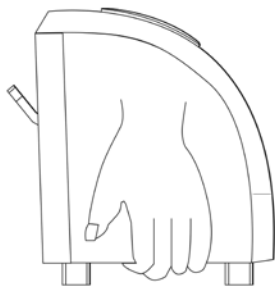

- Do not shake or drop the blade holder, a blade tip can fly out.
- During an operation, do not touch any of the moving parts of this machine (such as the carriage). Also be careful to make sure that clothing and hair do not get caught.
- Always connect the power cable to a grounded outlet.
- Always use the accessory power cable that is provided. Do not wire the power cable so that it becomes bent or caught between objects.
- Do not connect the power cable to branching outlet to which other machines are also connected, or use an extension cable. There is danger of overheating and of mis-operation of the machine.
- Keep the tools away from children where they can reach.
- Always put the pinch rollers within the white marks.

Table of Contents

Important Information

1. General Information

1.1	Package Items	1-1
1.2	Product Features	1-1
1.3	The Appearance	1-2

2. Installation

2.1	Precaution	2-1
2.2	Stand & Flexible Media Support System	2-2
2.3	Blade Installation	2-6
2.4	Media Loading	2-8
	2.4.1 Loading the Sheet Media	2-8
	2.4.2 Loading the Roll Media	2-10
	2.4.3 How to change the poll size without turning off the machine?	2-10
2.5	Cable Connections	2-11
	2.5.1 USB Interface	2-11
	2.5.1.1 Connecting your GCC cutter	2-11
	2.5.1.2 Installing the driver	2-11
	2.5.1.3 Driver Un-installation	2-14
	2.5.2 RS-232 Interface	2-17
	2.5.3 Data Transmitting	2-18
	2.5.4 Printer Sever Shared Setting	2-18
2.6	Software Installation	2-21
	2.6.1 GreatCut Installation	2-21
	2.6.2 Sure Cuts A Lot Installation	2-26
	2.6.2.1 Auto Installation	2-26
	2.6.2.2 Manually Activate Software	2-30
	2.6.2.3 Re-install Sure Cuts A Lot Software	2-31

3. Operation

3.1	The Control Panel	3-1
3.2	VLCD	3-2
3.3	File Uploader	3-5
3.4	Data Transmission	3-6
3.5	AR-24 Print Driver setting	3-6
	3.5.1 Option Page	3-6
3.6	Reference Parameter setting for different materials	3-9

4. Basic Maintenance

4.1	Cleaning the cutting Plotter	4-1
4.2	Cleaning the Grid Drum	4-1
4.3	Cleaning the Pinch Rollers	4-2

5. Trouble Shooting

5.1	What if AR-24 cannot Operate?	5-1
5.2	Cutting Quality Problems	5-2

Appendix







A-1	AR-24 Specification	A-1
A-2	Blade Specification	A-2
A-3	CorelDraw Instruction	A-3
A-4	Sure Cuts A Lot	A-4

Chapter 1 General Information

1.1 Package Items

The package of AR-24 contents the items listed below, please check carefully.

If you find any item missing, please consult your local dealer for further assistance.

Item	Quantity	
Cutting Plotter	1 Set	
Accessories	1 Set	
1. Installation DVD	2. Power Adapter	3. Paper Slicer
		
4. Cutting Pad	5. USB Cable (1.8m)	6. Cushion in tool carriage
		

1.2 Product Features

The followings are the main features of the AR-24 cutting plotters:

- Dual-port connectivity – USB & Serial interface
- Up to 250 gram cutting force
- Up to 552 mm/per second (21.7 ips) cutting speed (at 45° direction)

1.3 The Appearance (AR-24)

1.3.1 The Front View

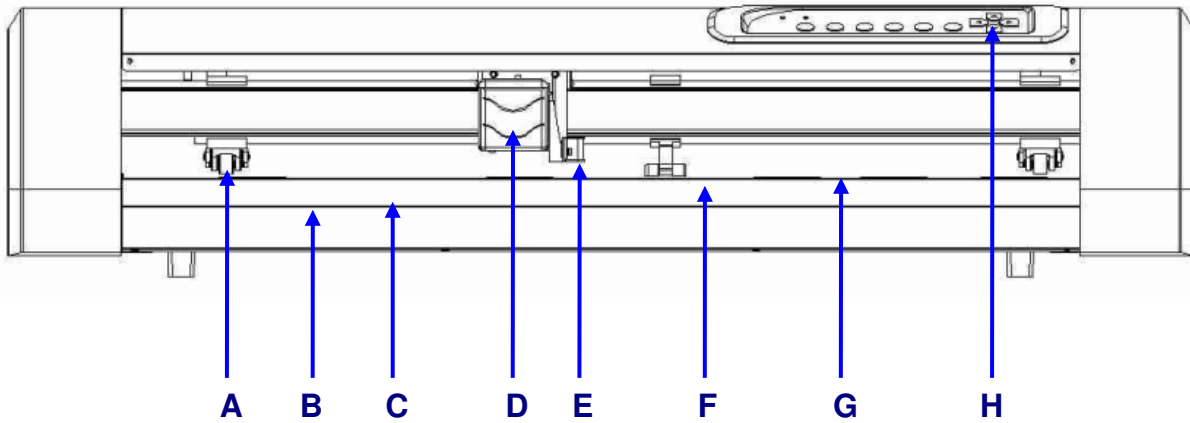

【Figure 1-1】

Object	Description
A Primary Pinch Roller	To help hold the media during cutting.
B Slicing Groove	To help slice off media.
C Alignment Ruler	To align media with clear guideline marks
D Tool Carriage	To help perform cutting job with installed blade or pen.
E Blade Holder	To hold the blade.
F Platen	The surface for holding and supporting media in operation.
G Cutting Pad	To protect blade and plate in operation.
H Control Panel	To consist of 10 control keys and 2 LED lights.

1.3.2 The Back View

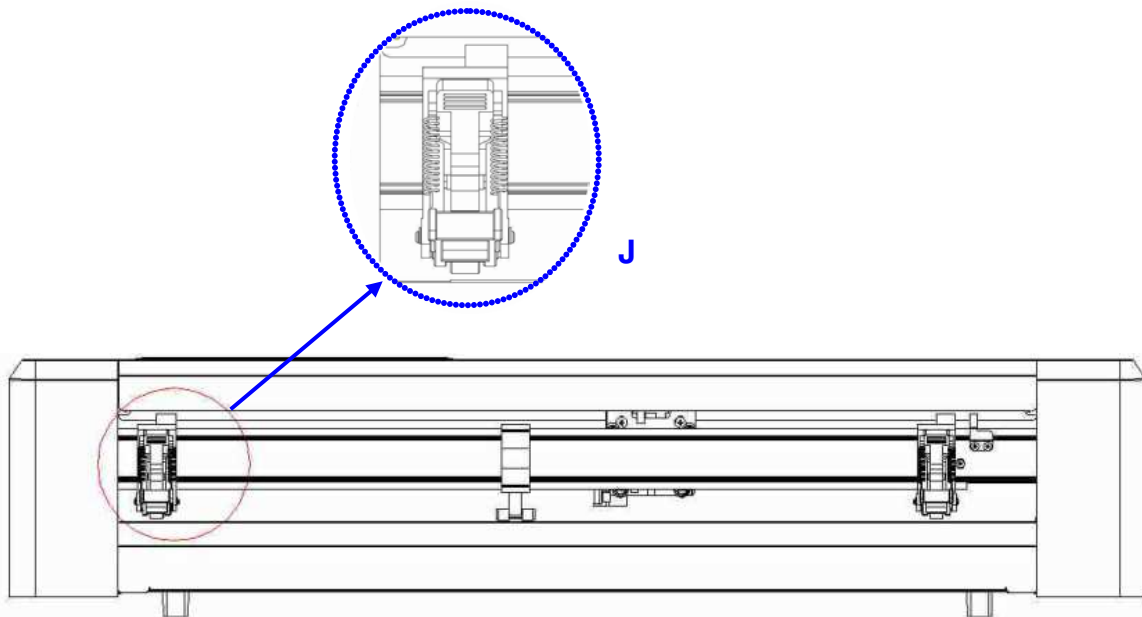

【Figure 1-2】

Object	Description
J Grid Drum	To move media back and forth in operation.

1.3.3 The Side Views

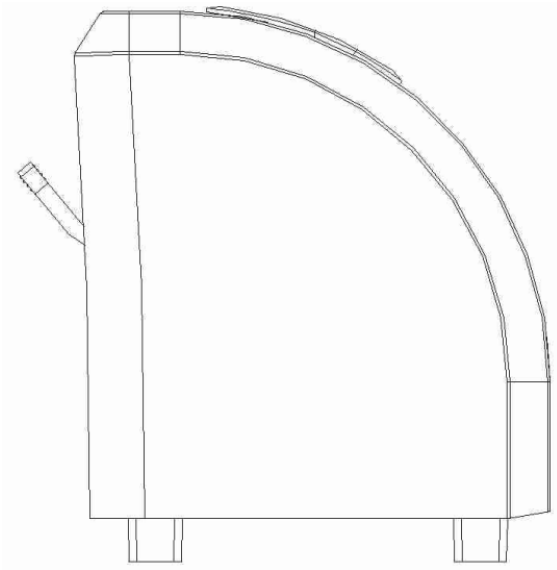

【Figure 1-3】

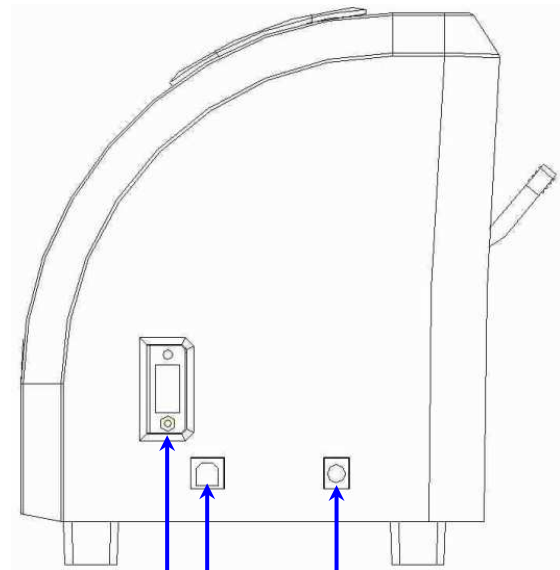

【Figure 1-4】

Object		Description
K	Serial Interface Connector	To connect the machine with a computer through a RS-232 cable.
L	USB Connector	To connect the machine with a computer through a USB cable.
M	AC Power Connector	To insert the AC power cord.

Chapter 2 Installation

2.1 Precaution

Please read below information carefully before you start installation.

Notice 1

- Make sure the power switch is off before installing the cutting plotter.
- Carefully handle the cutter to prevent any injuries.

Notice 2 Choosing a proper place before setting up the cutting plotter

Before installing your cutting plotter, select a suitable location, which meets the following conditions.

- The machine can be approached easily from any direction.
- Keep enough space for the machine, accessories and supplies.
- Keep the working area stable, avoiding severe vibration.
- Keep the temperature between **15 and 30°C (60-86°F)** in the workshop.
- Keep the relative humidity between **25% and 75%** in the workshop.
- Protecting the machine from dust and strong air current.
- Preventing the machine from direct sunlight or extremely bright lighting.

Notice 3 Connecting the Power Supply

Check the plug of the power cord to see if it mates with the wall outlet. If not, please contact your dealer.

- Insert the plug into a grounded power outlet.
- Insert the other end (male) of power adapter into the AC connector (female) of cutting plotter.

Notice 4 Tightening or Loosing Screws with Screwdriver

Whether manual or electric screwdriver, be careful not to use excess torque force when tightening or loosing screws. When tightening or loosing iron and stainless steel screws, please refer to the following screw torque standard table, other materials screws are not included.

Screw diameter	Torque value (kgf-cm)
	Torque standard for high hardness materials
M3	6
M4	16
M5	30
M6	50

2.2 Stand (Optional item)

2.2.1 Stand Installation

Please follow the procedures below for assembling the stand and the media support system.

Step 1

Please examine the supplied items in the accessory box of the carton before you install:
Stand is a standard item for AR- 24, Item List :

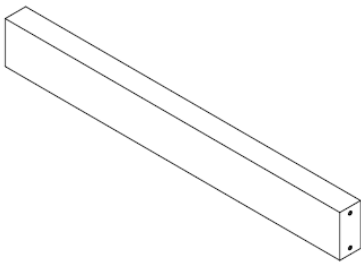

Beam x 1

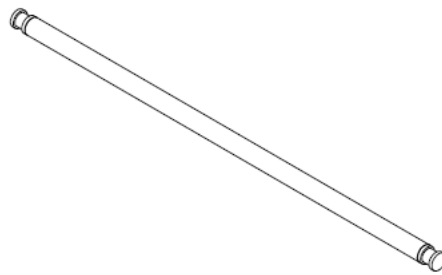

Roll holder x 1

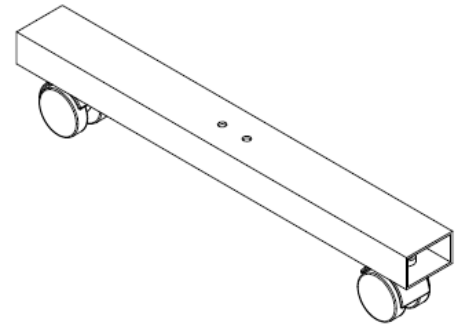

Bottom stand x 2

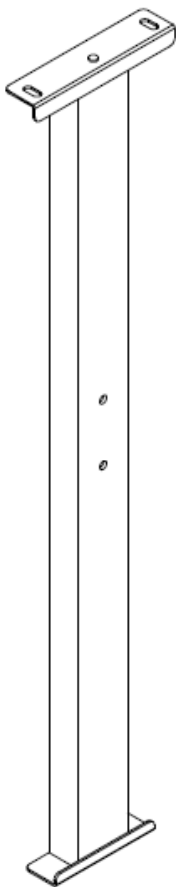

Vertical stand x 2

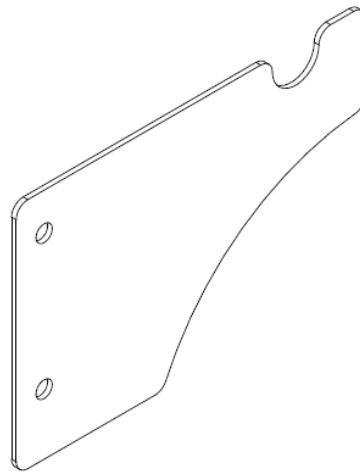

Roll holder support x 2

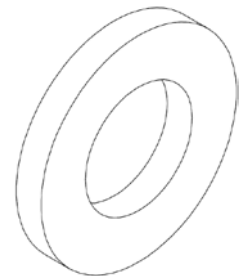

Flat washer x 12

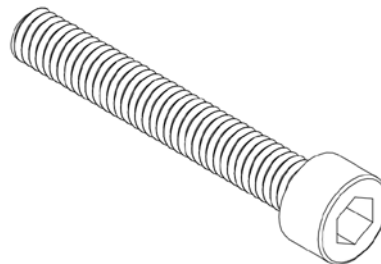

Screw-L x 8

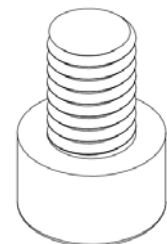

Screw-S x 4

Step 2

Place the beam upright on the left / right side vertical stand, and tighten the roll hold supports to the vertical stands and beam with screws-L and flat washers. (Figure 2-1)

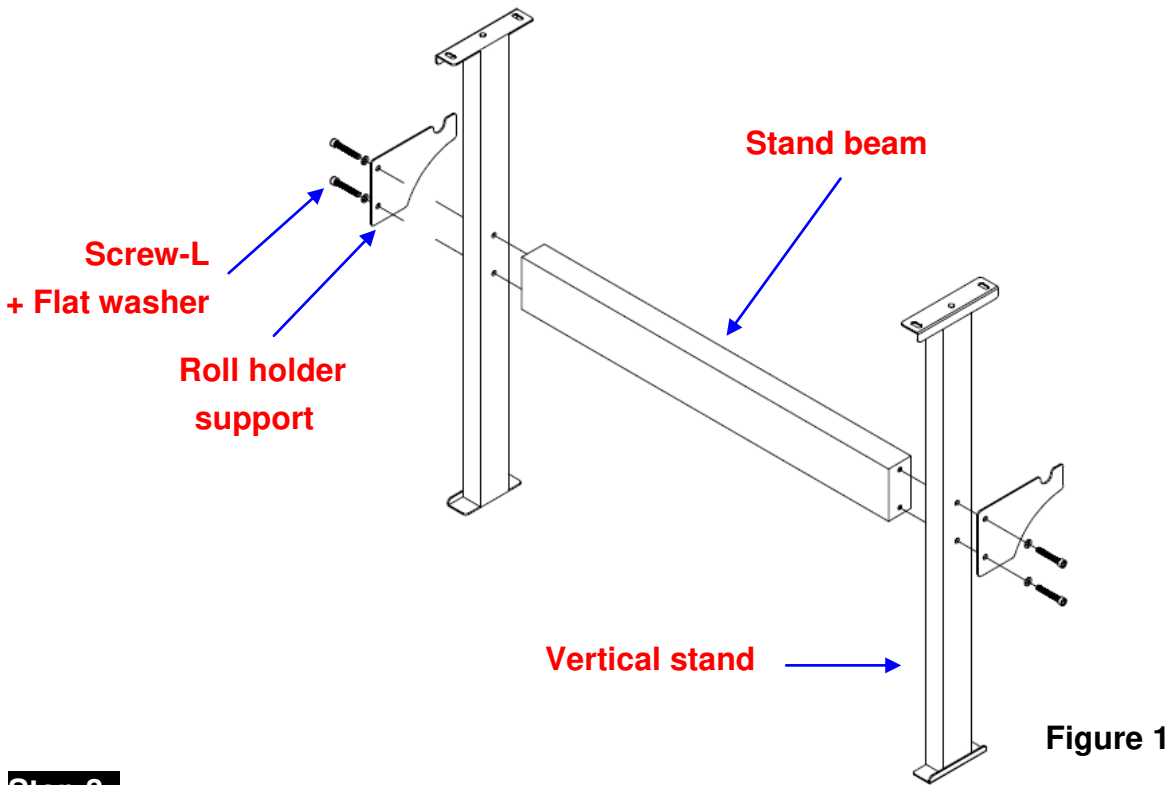

Step 3

Position the assembled stands perpendicularly, and tighten the assembled vertical stands to the bottom stands with screw-L and flat washer. (Figure 2-2)

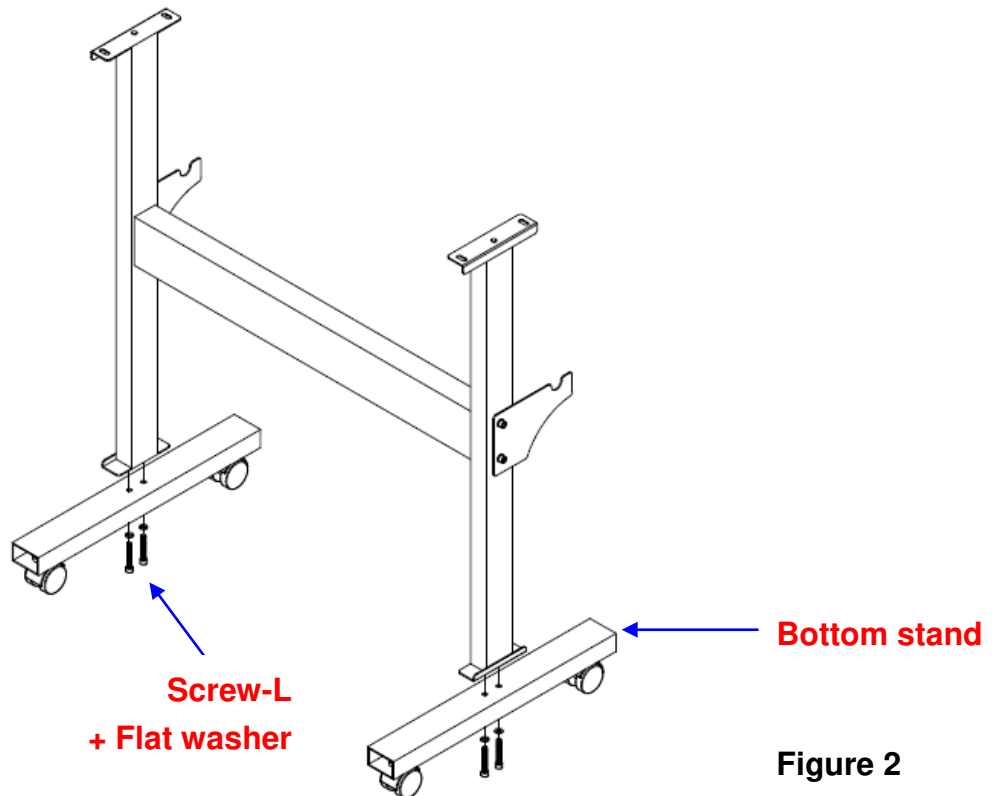

Step 4

Position the stand under the plotter, and tighten the plotter onto vertical stands with screw-S and flat washer. (Figure 2-3)

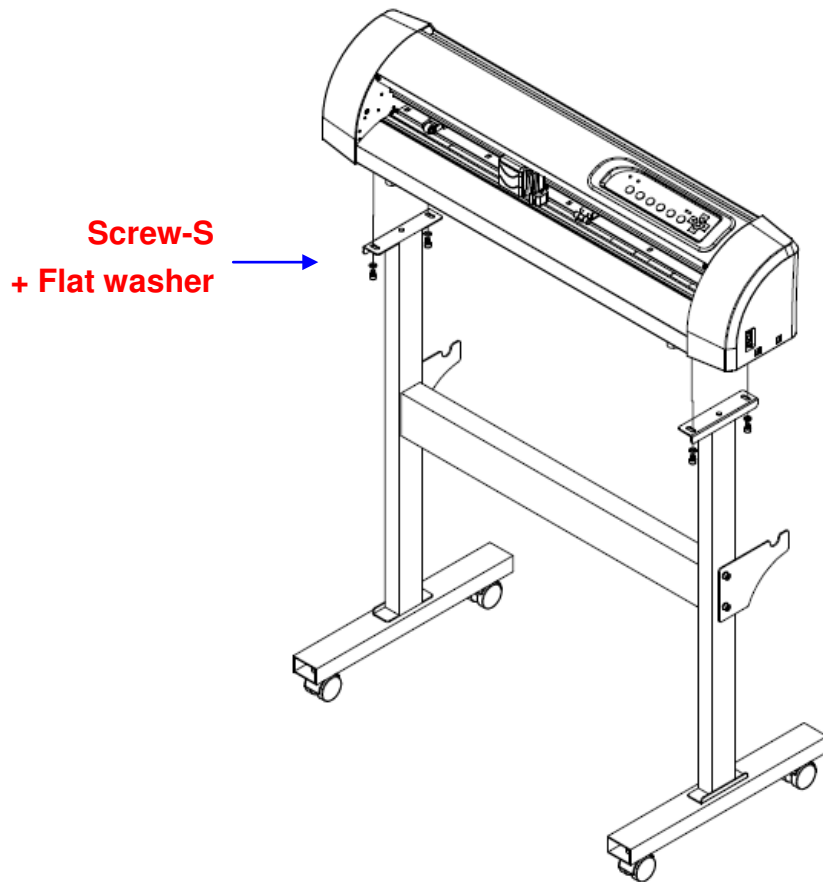

Figure 3

Step 5

Insert the roll holder into the roll media. (Figure 4)

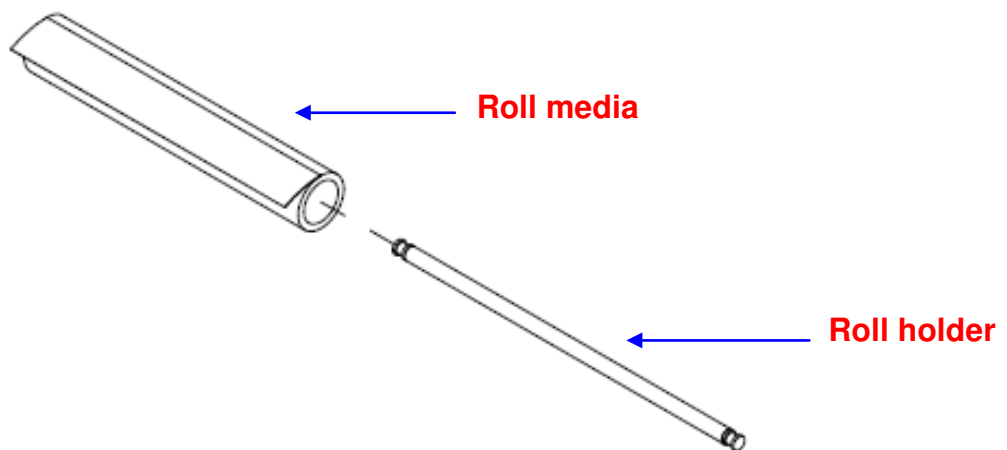

Figure 4

Step 6

Place the roll holder with media onto the roll holder support. (Figure 5)

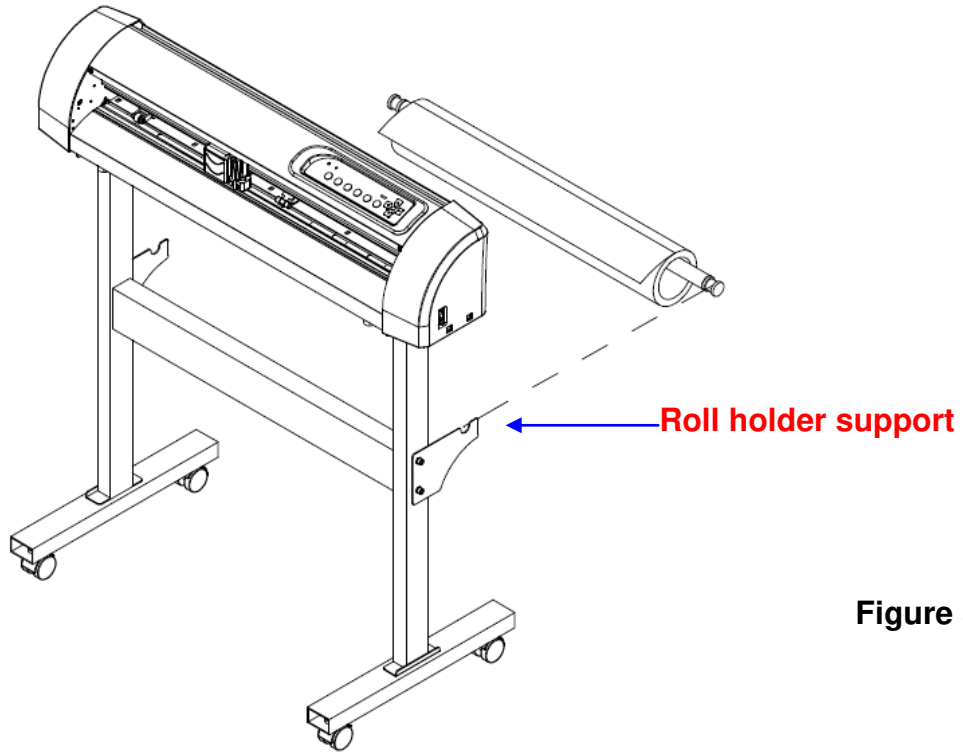

Figure 5

Step 7

The complete picture will be shown below. (Figure 6)

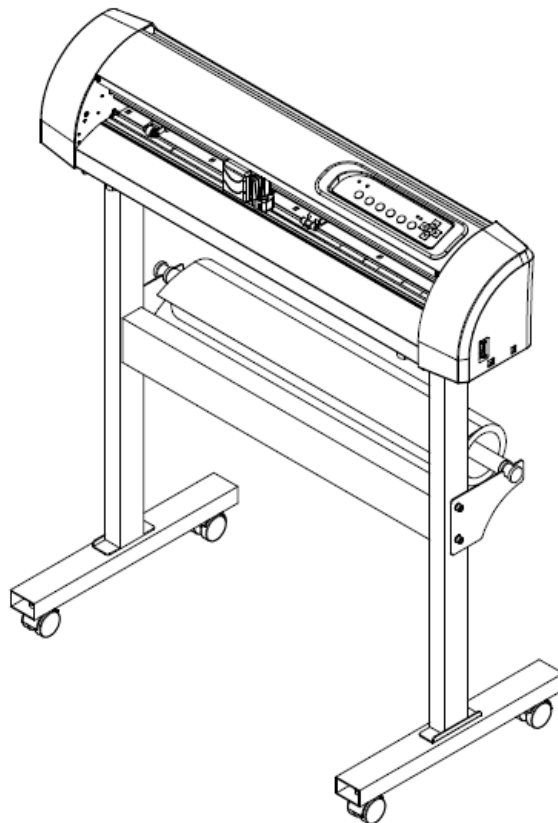

Figure 6

2.3 Blade Installation

Figure 2-7 is the illustration of the blade holder. Insert a blade into the bottom of the blade holder, while pushing the top pin to remove the blade. Make sure your fingers are away from the blade tip.



Step 1

Install blade (Figure 2-8).



Figure 2-8

Step 2

Push the blade to the bottom of the blade holder (Figure 2-9).



Figure 2-9

Step 3

Adjust the blade tip to suitable length by screwing "Blade tip adjustment screw" clockwise or count-clockwise (Figure 2-10).



Figure 2-10

Tips:

"The proper length" means the blade's length is adjusted 0.1mm more than media's thickness. That is, if the thickness of film is 0.5mm, then blade's length is properly adjusted 0.6mm and it can completely cut through the film layer yet avoid penetrating the backing.

Step 4

Insert the blade holder into tool carriage. Please note the outward ring of the holder must put into the grooves of carriage firmly (see Figure 2-11), fasten the case (Figure 2-12).

**Figure 2-11****Figure 2-12****Step 5**

Use the reversing steps to remove the blade holder

Step 6

Eject the blade: Push “Blade eject pin” to eject blade when the blade **needs to be replaced**.

Caution!!

The blade will lose its sharpness after a period of usage; hence the cutting quality might be affected. By increasing the cutting force, it might do the trick. However, once the blade is worn out and no longer provides a reliable cutting, you should replace a new one. The blade is consumable and must be replaced as often as necessary to maintain the cutting quality. The quality of the blade deeply affects cutting quality. So be sure to use a high quality blade to ensure good cutting results.

Tips - When to replace a new blade:

- ✓ If the blade is broken, you have to replace a new one.
- ✓ If cutting quality is not as good as usual, you may need to replace a new one.
- ✓ If the material cannot be cut through by higher cutting force, you may need to replace a new one.

2.4 Media Loading

2.4.1 Loading the Sheet Media

To load the media properly, please follow the below procedures:

Step 1

Lift the 2 levers at the backside of cutter to release pinch rollers (Figure 2-13).



Figure 2-13

Step 2

Load your media on the platen and slide it under the pinch rollers from either the front side or the backside. The **alignment rulers** on the platen extension will help you to adjust the media precisely (Figure 2-14).



Figure 2-14

Step 3

Then move the pinch rollers manually to the proper position. Be sure the pinch rollers must be positioned above the grid drum. **The white marks on the main beam will remind you where the grid drums are** (Figure 2-15).

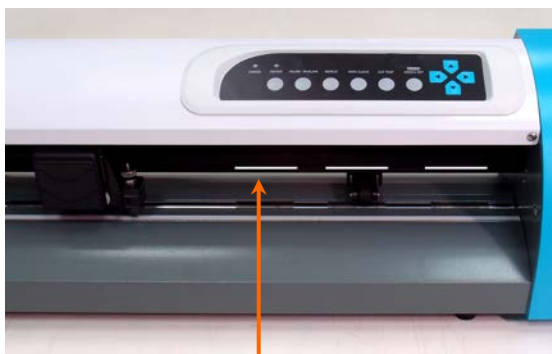

Figure 2-15 White mark

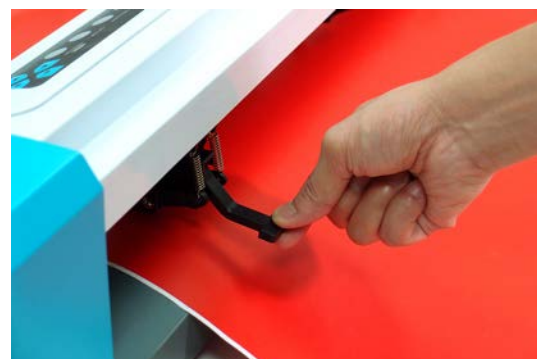

Figure 2-16

Step 4

Push the lever backward to lower down and fix the pinch rollers (Figure 2-16).

Step 5

After turn on the power, the tool carriage will measure the size of the media automatically. The plotting cutter begins to work.

CAUTION!!

- ✓ Make sure the Primary and Secondary pinch rollers are set to right positions.
- ✓ Position the Primary Pinch Rollers at the right and left sides of media. Position the Secondary Pinch Roller at the center of media.

(O) Correct

Figure 2-17

Secondary Pinch Roller Primary Pinch Roller

(X) Incorrect

Figure 2-18

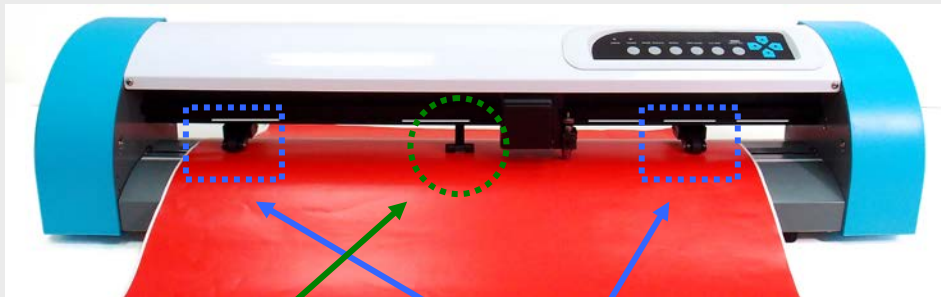
NOTE:

- ✓ Always adjust the position with the pinch rollers released (raised).
- ✓ Always reposition the pinch roller by holding the center of the pinch roller and move it from the **REAR** end of the machine. (Figure 2-19)
- ✓ DO NOT move the pinch roller by holding its **FRONT** rubber roller (Figure 2-20).

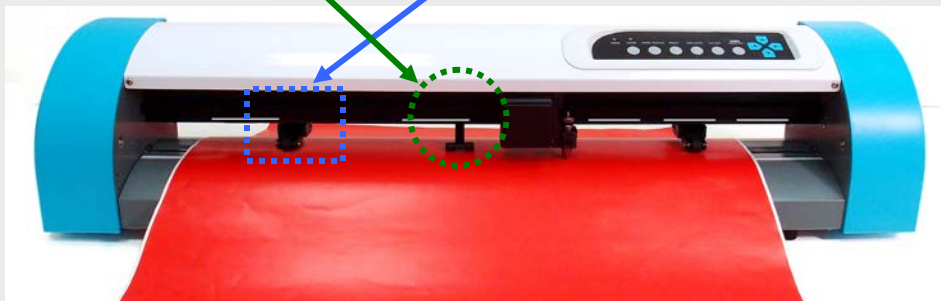

Figure 2-19



Correct



Figure 2-20



Incorrect

2.4.2 Loading the Roll Media

You can use the stand with flexible media support system. Please refer to Chapter 2.2 for hardware setup, and Chapter 2.5.1 for media loading.

2.4.3 How to change the poll size without turning off the machine?

Press origin set twice and the machine will start moving to get the new size. Then open the VLCD and under the poll size you will find the new measurements.

2.4.4 Change the cushion periodically

Cushion in tool carriage is used to absorb vibration and lower the noise caused by moving tool carriage. It is suggested to replace the cushion every six months to retain the effect.

2.5 Cable Connection

The cutting plotter communicates with a computer through a **USB (Universal Serial Bus)** or a **Serial port (RS-232C)**. This chapter shows you how to connect the cutting plotter to a host computer and how to set up the computer and cutting plotter interconnection.

NOTICE: When USB connection is enabled, serial port will be disabled automatically.

2.5.1 USB Interface

AR-24 build-in USB interface are based on the Universal Serial Bus Specifications Revision 2.0 (Full Speed).

2.5.1.1 Connecting your GCC cutter

1. Turn on the machine.
2. Connect the USB connector to the machine and then USB driver will installed automatically. It will take a few minutes to find the device. Please **DO NOT** disconnect the USB cable until the installation has completed.
3. You can double click the USB icon on the taskbar to make sure the USB device is detected.

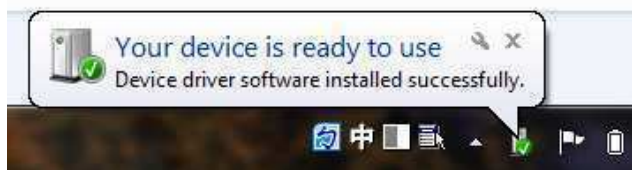

2.5.1.2 Installing the driver

Use the USB One-click Installation for quick driver installation. Follow the simple steps below for driver setup.

Caution!!

- ✓ If you are using Windows 7 and above as your operating system, make sure you log in using the "Administrator" account.

Step 1 Put the installation DVD into your CD-ROM. **Please make sure that the USB device is connected before you start the driver installation.**

Step 2 Choose the model you want to install from the driver list and click on Windows Driver (Win 7 and Above) (Automatic Detection) or Windows Driver (Win 7 and Above) (Manual Selection) to start installing the Driver and AAS plug-in.



Step 3 Click “Next” to start the driver installation.

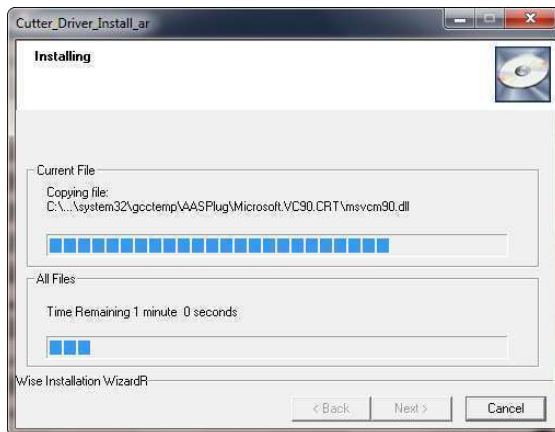

Step 4 If you were Windows 7 and above users, please click on the **red words** to instruct you how to disable Windows Update to allow success driver installation. And then click OK to next step.



Step 5 Please make sure the cutting plotter is powered on and connected to the USB device, and then click OK to next step.

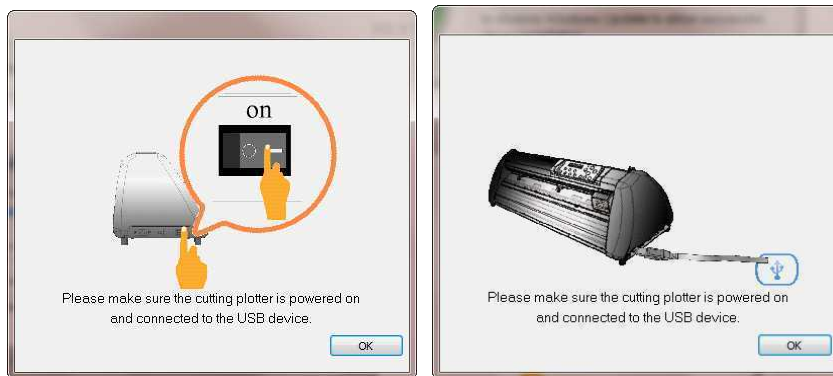

Step 6 Confirm to close all running application programs before you start installing the driver, and then click OK.



Step 7 The installation will take a few minutes to complete and you will see a message below and click on “OK” upon completion. Enjoy your GCC cutter!

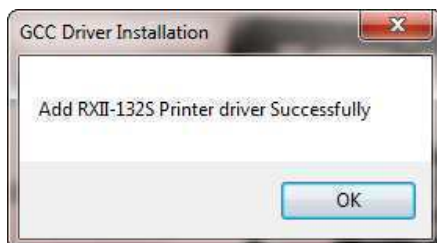

Note:

(1) If the driver is being installed for a second time, the user will be prompted as to whether a second copy of the driver installation is required.



(2) If the user selects yes, a second copy of the driver will be installed.

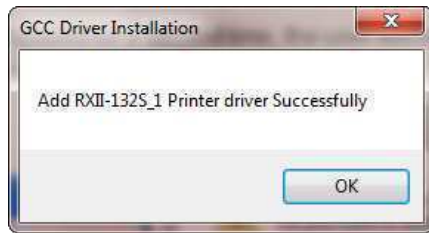

2.5.1.3 Driver Un-installation

You have to remove previous version driver installed on your PC system completely before you can install the latest version successfully. Please refer to below steps.

Step 1 Go to Control Panel\Hardware and Sound\Devices and Printers window. Right click the printer and select “**Remove device.**”

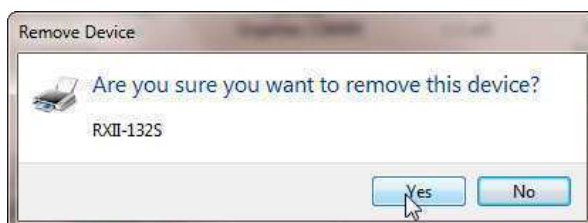
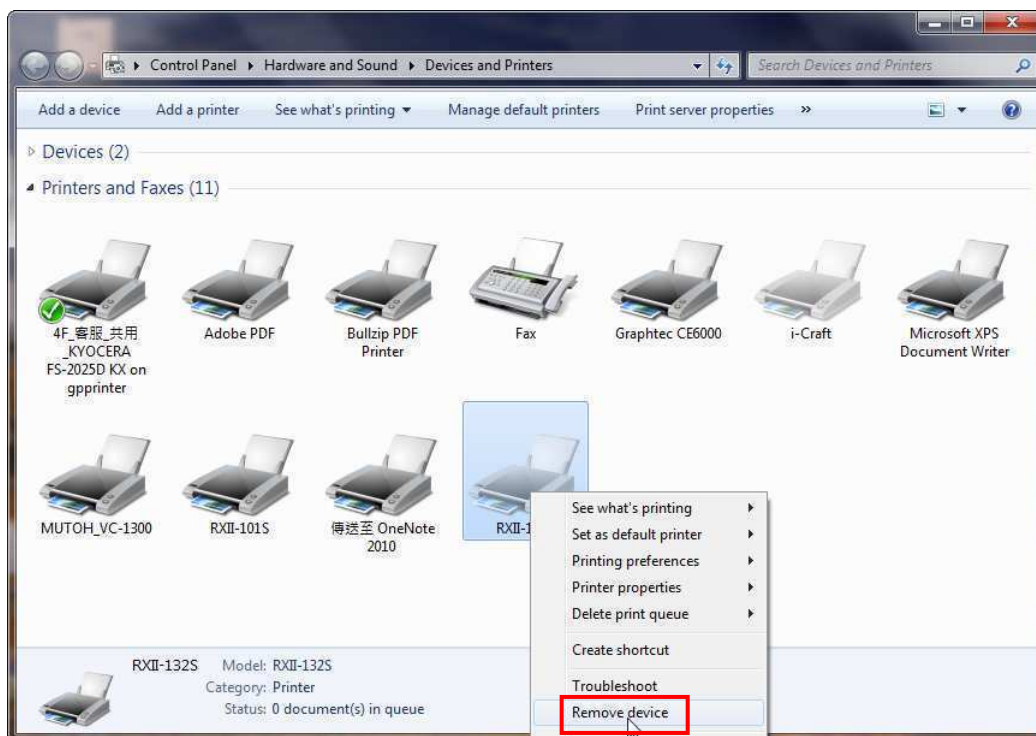

- Step 2** After removing the unit, click on any printer on the page and select **“Print server properties.”** (For Win 7 and above)
Or right click on blank space and then select **“Print server properties.”** (For Windows XP)

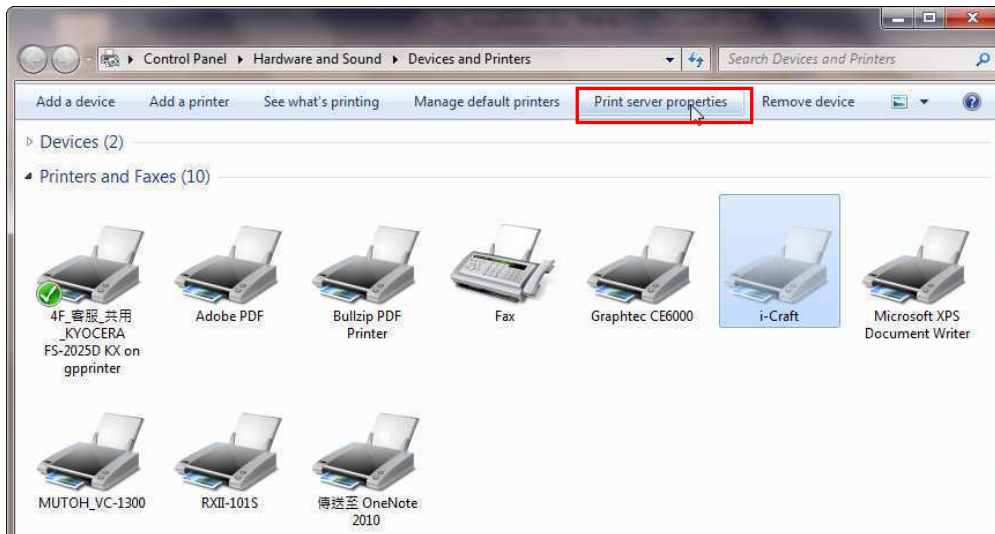

- Step 3** Select **“Driver”** page

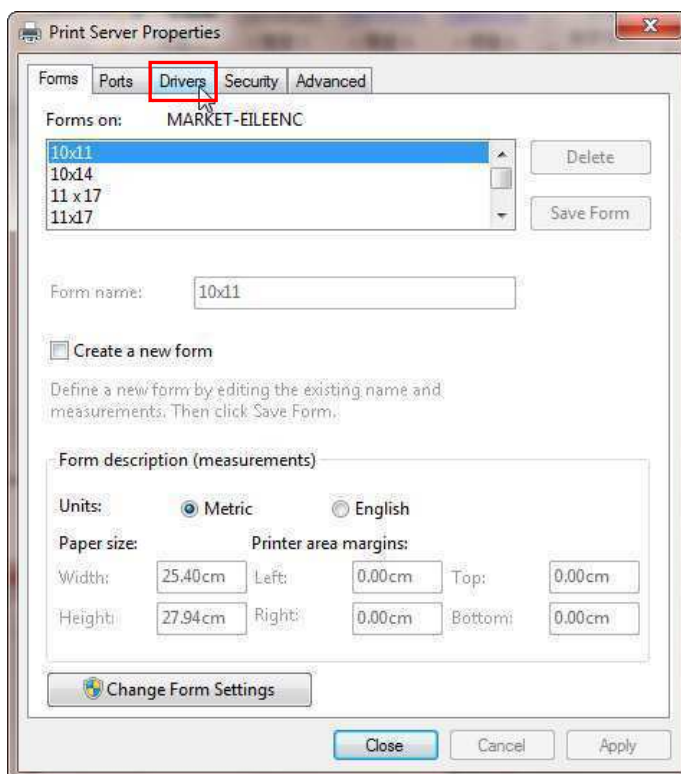

Step 4 Select the model and click on “Remove”.

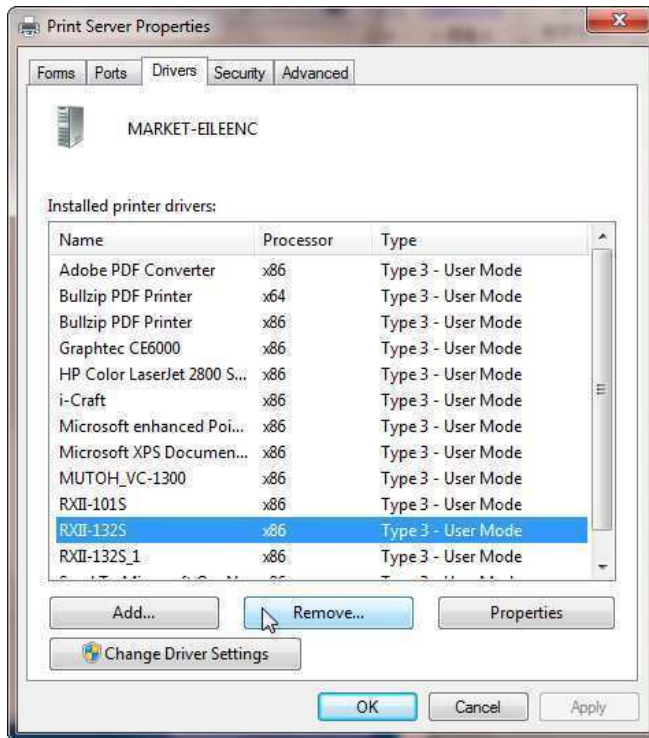

Step 5 Select “Remove driver and driver package” and click OK.



Step 6 Click Yes and then click “Delete” and “OK,” and the driver installed on PC is completely removed.

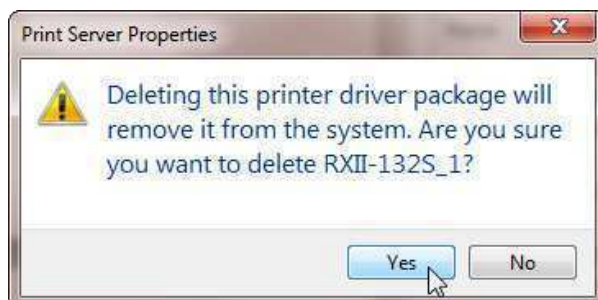

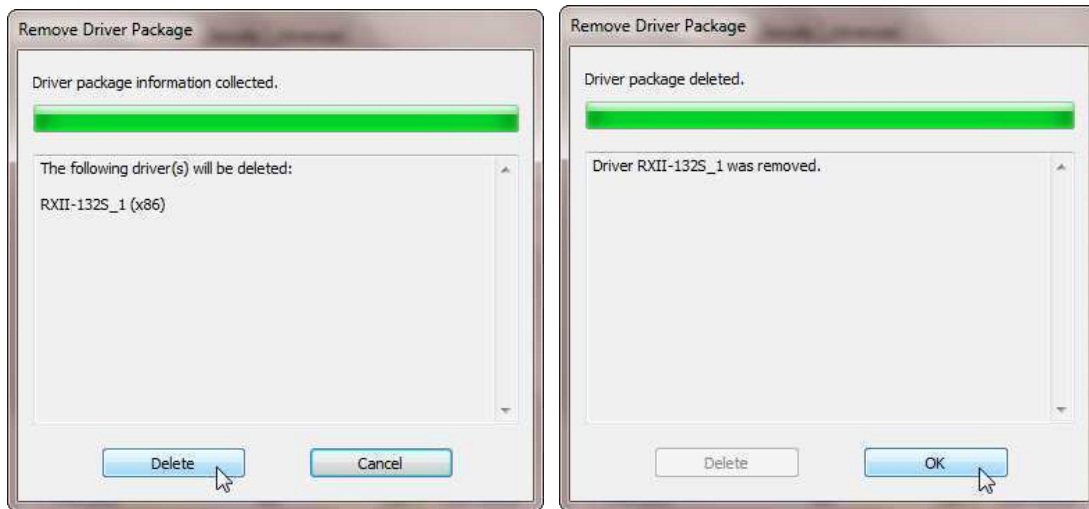

2.5.2 RS-232 Interface

■ Connecting to the RS-232 (Serial) Port

1. For IBM PC, PS/2 users or compatibles, connect the RS-232C cable to the serial connector of the assigned serial port (COM1 or COM2) of your host computer.
2. Set up the communication parameters (Baud Rate and Data Bits/Parity) to match the setting of software package, refer to chapter 3 – “Misc” key description.

Caution!! Please turn off the plotter before plugging the RS-232C

2.5.3 Data Transmitting

There are two options to transmit the data from the computer to the cutting plotter:

Option 1: With proper interface settings, the data can be transmitted from your application software package to the cutting plotters directly.

Option 2: Most cutting software packages are able to emulate **HP-GL** or **HP-GL/2** commands. As long as the file is **HP-GL** or **HP-GL/2** format, the cutting plotter can output the data precisely.

2.5.4 Printer Server Shared Setting

In “A-PC”, set the printer driver as a shared printer, then use B-PC to connect A-PC’s printer driver via Intranet.

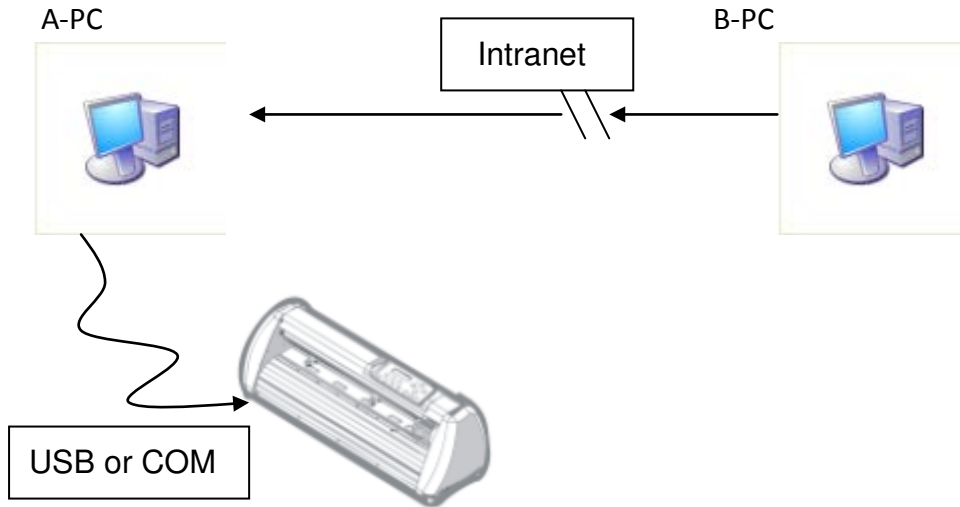

Step 1 Set A-PC’s printer driver as a shared printer (Right-click on printer icon, choose “Printer properties”. Click “Sharing” tab then check “Share this printer.”)

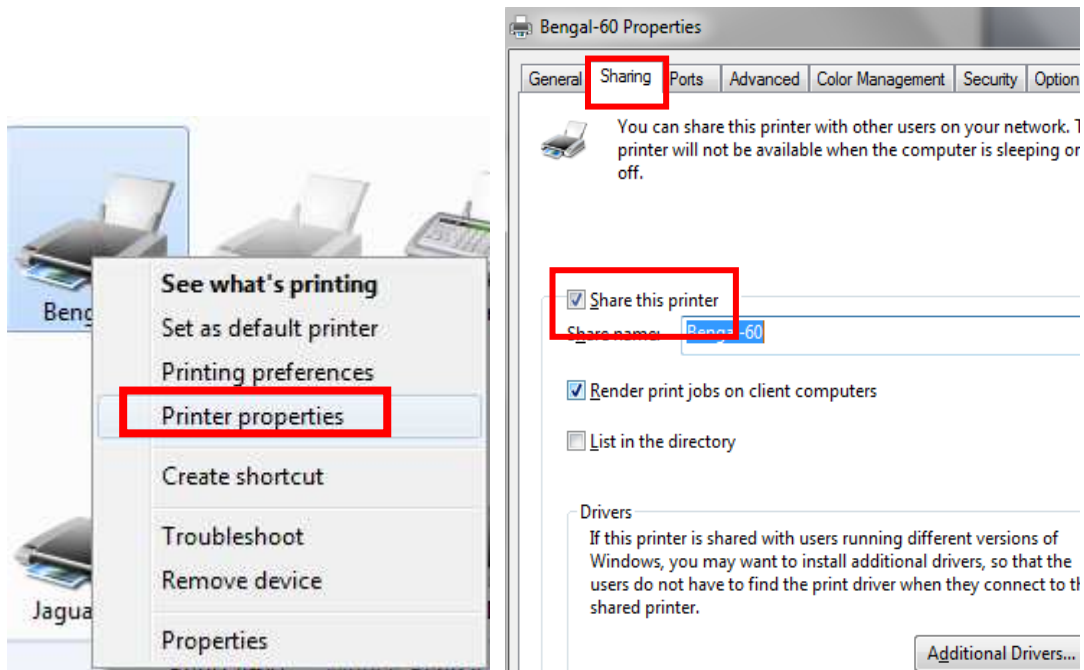

Step 2 Click “Advanced” tab, then choose “Print directly to the printer” option.

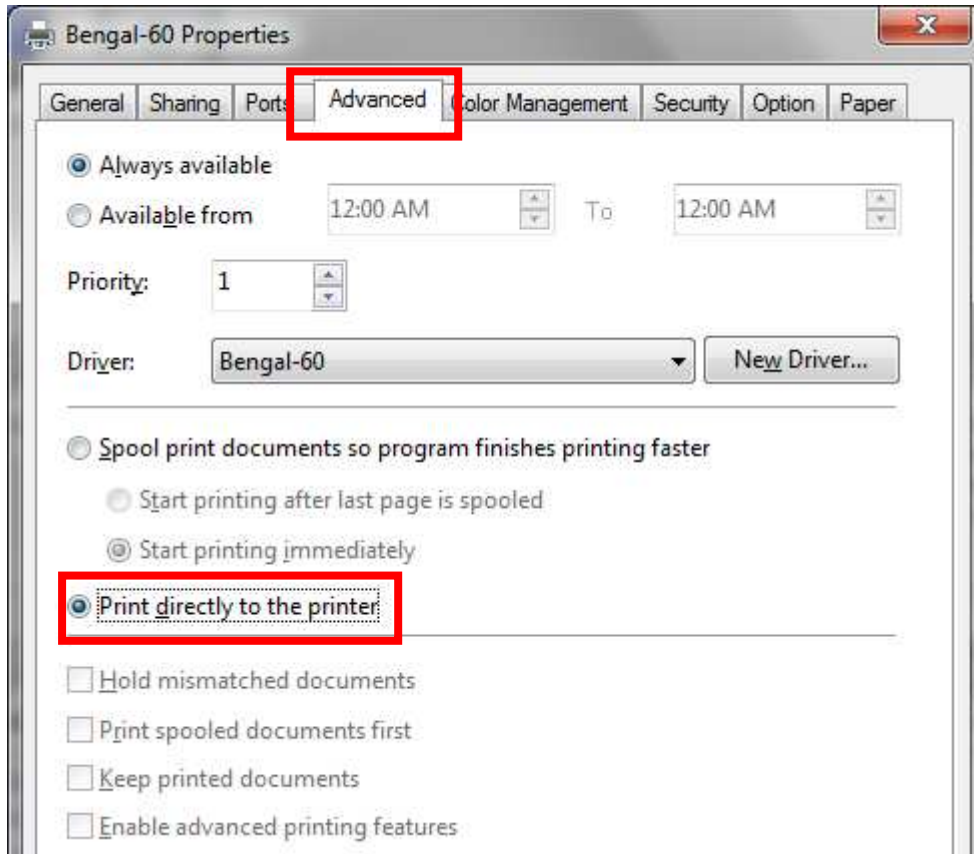

Step 3 Send a job from A-PC to the machine to check if A-PC is connected to the machine.

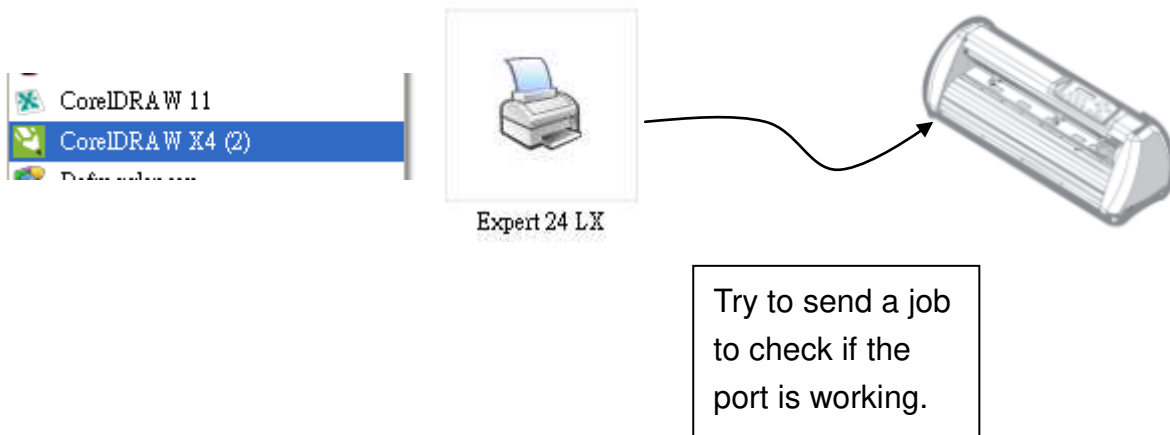

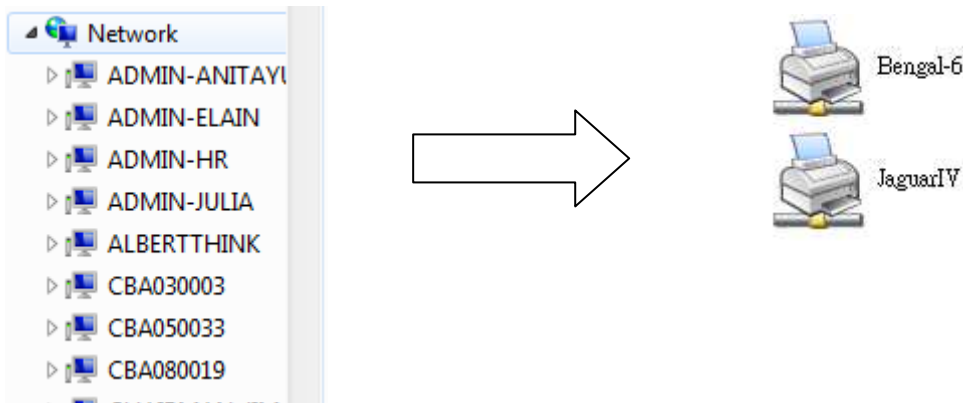
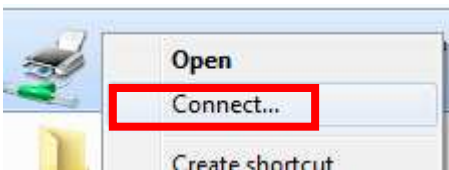
Step 4 Activate A-PC's Printer Driver from B-PC's Network.**Step 5** Right-click on the printer icon, and select "Connect" to A-PC's printer.

2.6 Software Installation

2.6.1 GreatCut Installation

Step 1 Click GreatCut Registration in installation DVD to go <http://gccvoucher.eurosystems.lu/>, and then enter your voucher code provided when purchasing GreatCut and click "Go on!"

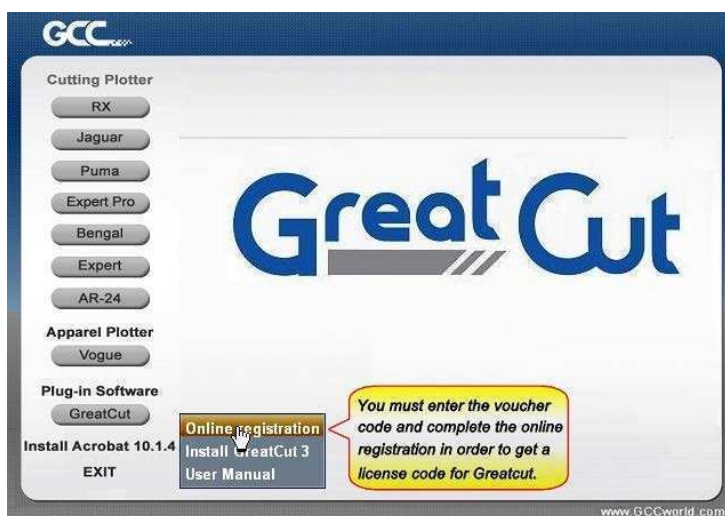

Great Computer Corp. Software Voucher Code

GCC Great Cut
STONECUT

Please enter your voucher code *completely* and *accurately* as it stands on the voucher.

Voucher Code

In case of problems or questions you can reach our technical support over tech.support@gcc.com.tw.

[[Homepage Great Computer Corp.](#)]

Step 2 Click “Request” to go to registration page.

Great Computer Corp. Software Voucher Code

GCC Great Cut

You are holding in your hands a software voucher for a full license of GreatCut 3.
In order to receive the **free of charge** license code and download GreatCut 3, please use the following button:

License code for new **full license**

[[Homepage Great Computer Corp.](#)]

Step 3 Fill in the required information and click “Request license code.”

Software Download GreatCut 3

Great Cut
Software Registration

Last name, first name: , ! Required fields
Would you please use Latin resp. West-European characters!

Company:

Street:

PO box:

City:

State/Prov.:

Zip (postcode):

Country:

Phone:

Fax:

eMail address:
Important: Pay attention to enter your eMail address correctly, because license code is sent to this address!

Step 4 The registration is completed; you should receive two emails, one is registration confirmation with activation link and another is your license data with **.ecf** file.

Registration Successful

Thank you, that you decided for GreatCut 3.

An email with further information for GreatCut 3 was sent to the given email address (eileen.chen@gcc.com.tw). Please be patient, as it may last up to 30 minutes until you can receive this email.

If you don't receive an email, please fill out the form on gccvoucher.eurosystems.lu again with a working email address.

[[Home Great Computer Corp.](#)]

Step 5 Check your email to see if you receive the activation link and click the link that will direct you the link for GreatCut download.

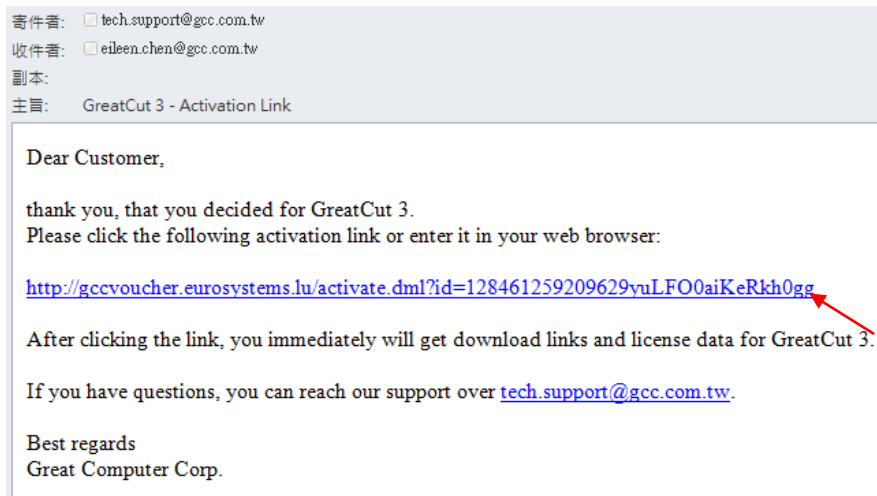

Step 6 Click “Install GreatCut” in installation DVD.



Step 7 Select a destination folder.

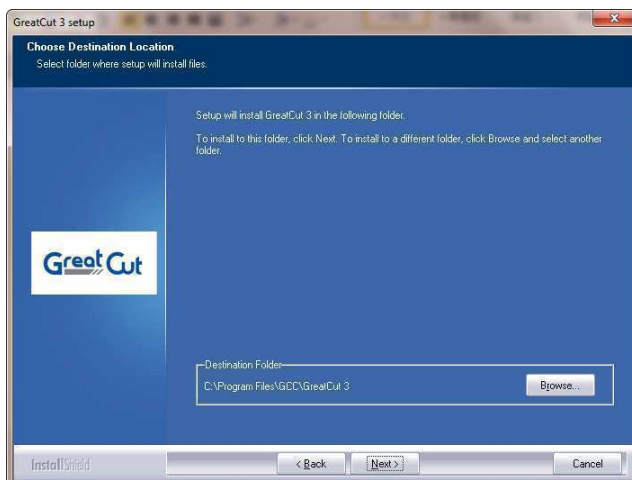

Step 8 Select Typical and click Next.

Note: You may select custom setup to install additional drivers.

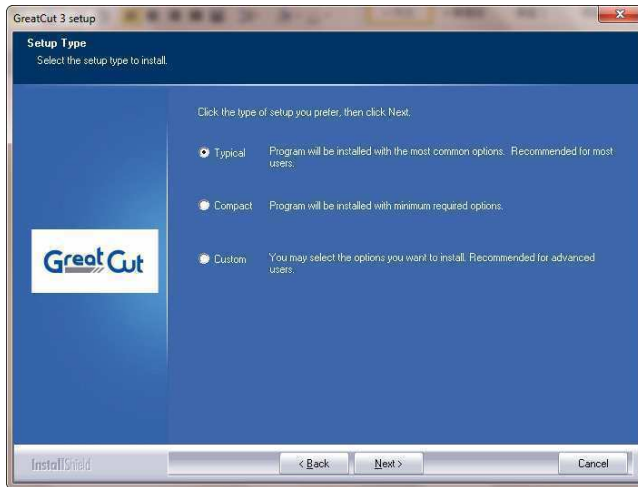
**Step 9** Select the folder and click Next.

Default program folder in the start menu is GCC\GreatCut 3.

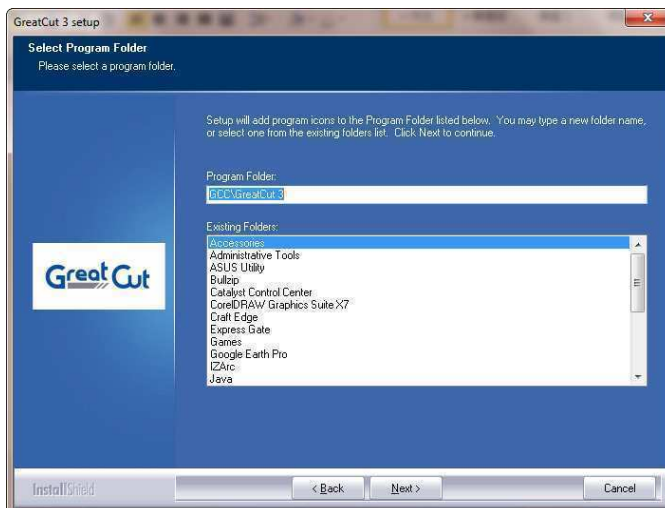
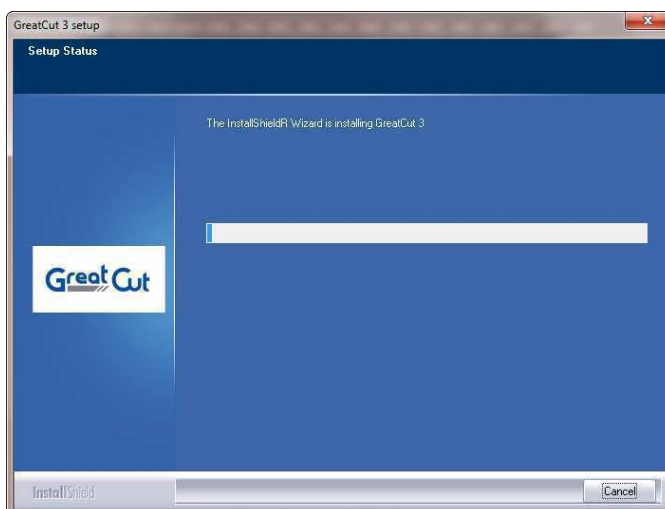
**Step 10** GreatCut is installing.

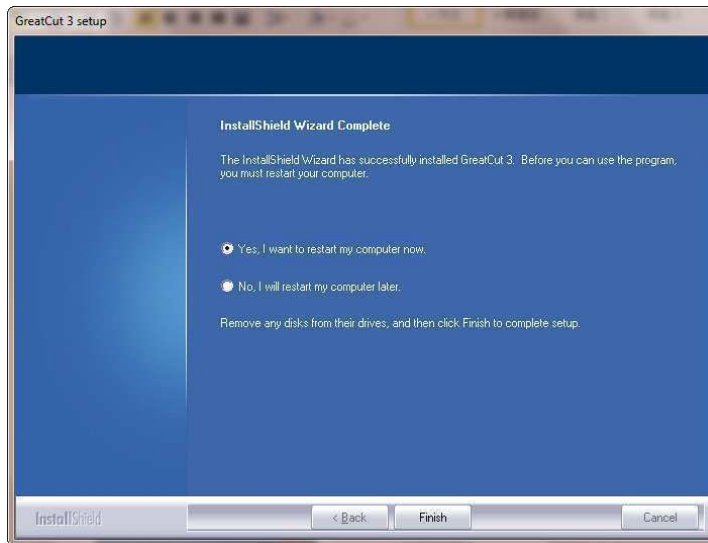
Step 11 Click Finish to complete installation.**Step 12** Before you launch GreatCut, open the **.ecf** attached to the license data email to install your license data to GreatCut so that you don't need to fill in your information again.

Step 13 If the license do not install successfully, you will need to fill in your license data manually. You can find the details of your license data from the email.

License data:

Note:
Please fill out the fields of the license data exactly as you received it.

Company / name:
|GCC|

eMail:
|keira.lee@gcc.com.tw|

Code:
|KGCC-XXXXX-XXXXX-XXXXX-XXXXX|

System information PIN:
|3666223328-0-9-1-57-MARKET-KEIRA2|

OK Cancel

寄件者: RCS-ONLINE <directdownload@eurosystems.lu> 寄件日期: 2015/2/25 (3)

收件者: eileen.chen@gcc.com.tw

副本:

主旨: GreatCut 3 - Receipt and License code

附件: GC16P-1867.ecf (273 B)

The following license code will be activated by copying or saving the attached file to the computer and starting it via double click. Thus the activation is done fully automatic and GreatCut 3 is ready to use.

For a possibly necessary manual input, here the license data (green) again in plain text:

Company / Name: GCC
eMail: eileen.chen@gcc.com.tw
Code: GC16P-XXXXXX-XXXXXX-XXXXXX-XXXXXX

Number of Licenses: 1
Serial No.: GC16P-1867

Step 14 GreatCut is ready to use now.



2.6.2 Sure Cuts A Lot Installation (Optional Item)

2.6.2.1 Auto Installation

Step 1 Put your installation DVD into your CD-ROM to start the installation. The software is compatible with Windows 7 and above and Macintosh OSX 10.6 and above.

Step 2 Select “Install Sure Cuts A Lot” to start the installation.

Step 3 Press Next to continue.



Step 4 Select “I accept the agreement” and press “Next.”

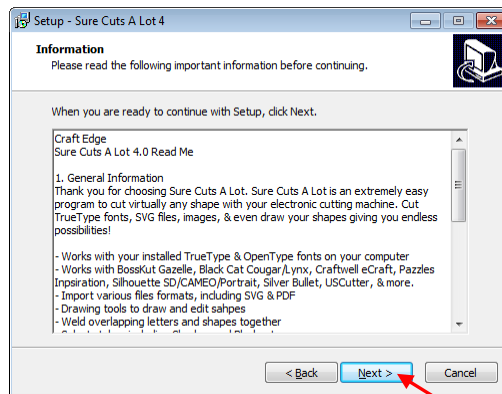
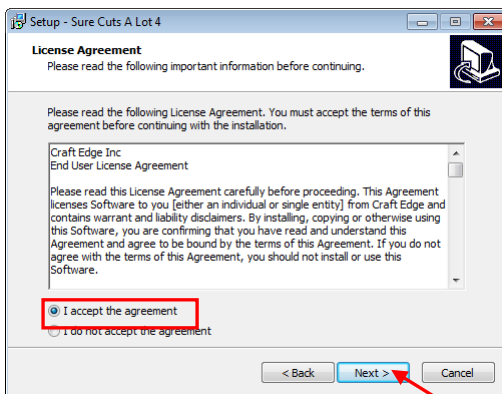

Step 5 Use the default folder (suggested) or select a folder you want to install the Sure Cuts A Lot and press “Next.”

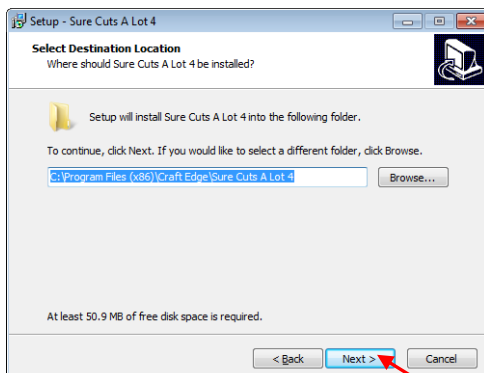

Step 6 Tick “Create a desktop icon” if you want to create a shortcut on your desktop, and tick “Associated scut4 extension” to associate the scut4 extension file with Sure Cuts A Lot software. Then press “Next” to start the installation.

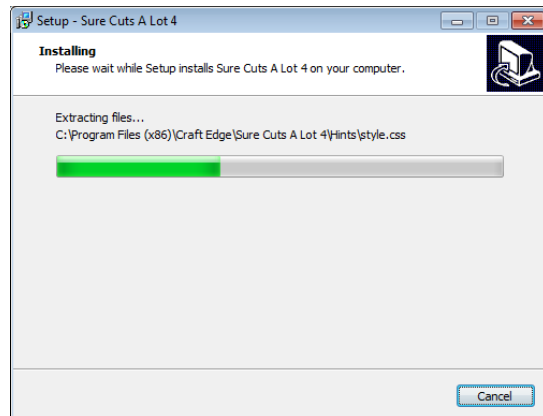
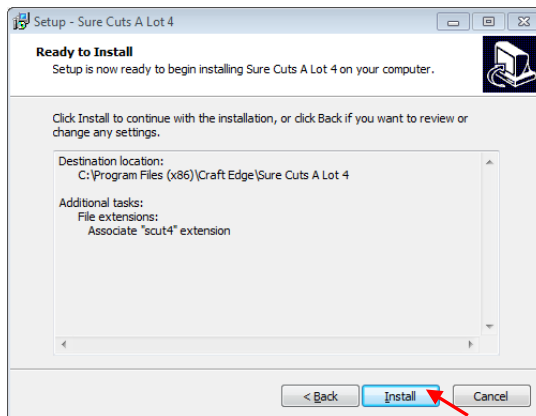
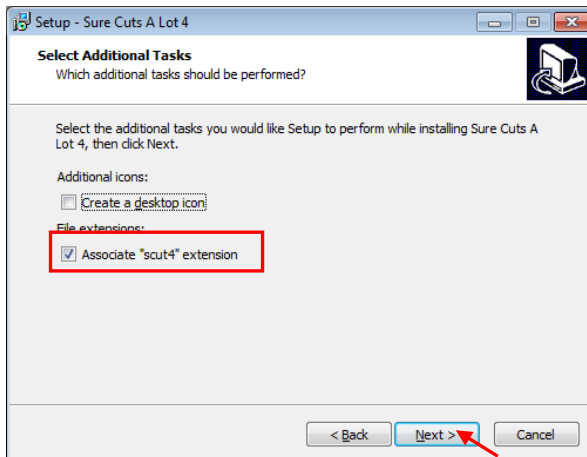

Step 7 Don’t tick “Install USB Driver” and tick “Launch Sure Cuts A Lot,” and then press “Finish” to complete installation.

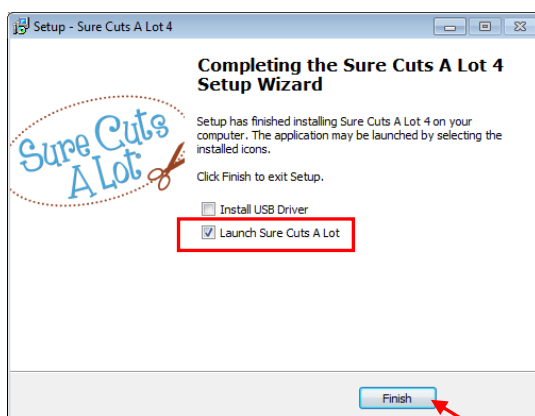

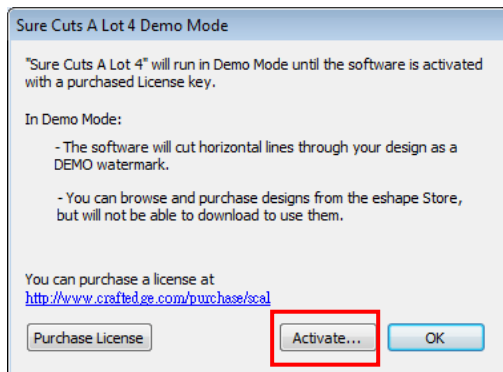
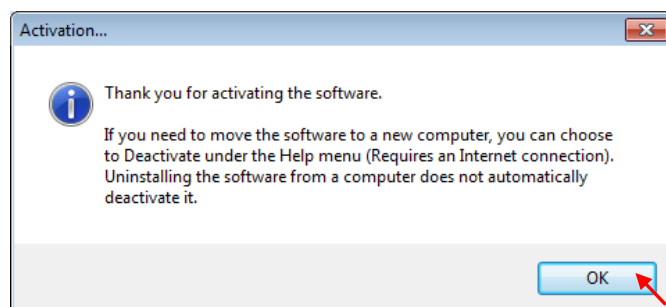
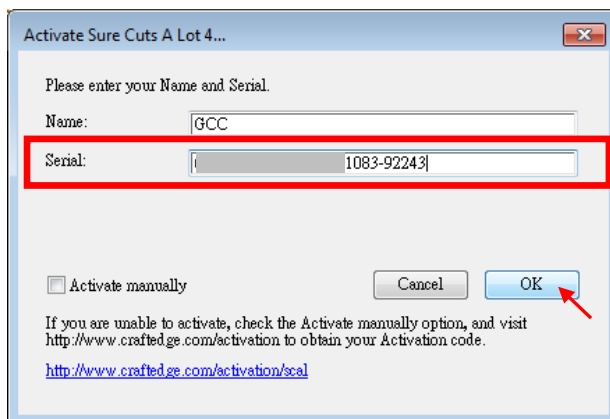
Step 8 Run Sure Cuts A Lot.**Step 9** Press “Activate...” to activate Sure Cuts A Lot. Please make sure it is connected to the internet.**Step 10** Put your name in the Name column and enter the 25-letter software key shown on the DVD front cover to the Serial column and press “OK” to complete the activation.

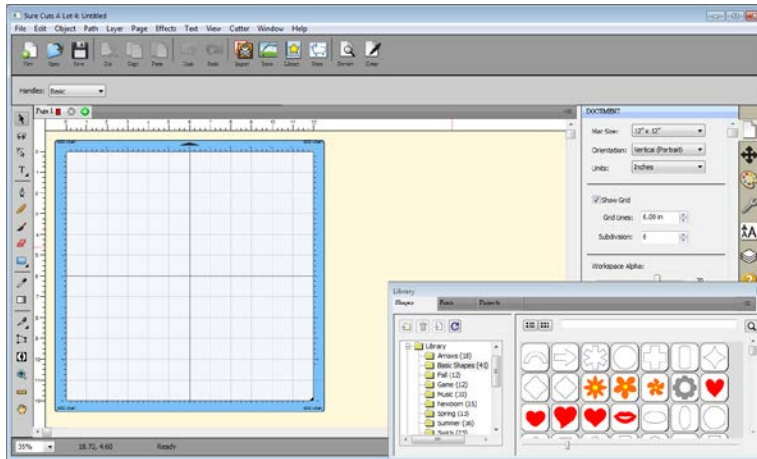
Step 11 Sure Cuts A Lot is ready to use.**Note**

- ✓ If you use a trial version to output graphics, meaning you do not enter the software key to activate the Sure Cuts A Lot mentioned above, there will be two extra lines cut through the design, therefore, make sure the Sure Cuts A Lot software is activated before implementing cutting jobs.

2.6.2.2 Manually Activate Software

If the computer connected to cutter doesn't have internet connection to accomplish above software activation process, you can use "Activate manually" function alternatively to enter the "Activation Code" to start the usage of Sure Cuts A Lot. Meanwhile, you need to find another computer that has internet access to obtain the "Activation Code" in advance following below instructions.

Step 1 Check the "Activate manually" checkbox and you should see the Site Code and Activation Code fields appear. The Site Code field will be pre-filled in and cannot be changed.

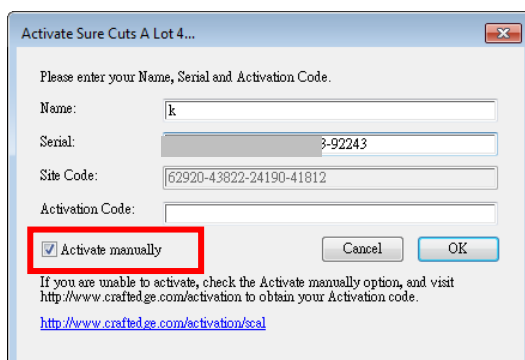

Step 2 Visit <http://www.craftededge.com/activation/surecutsalot> via an internet connected computer. Enter your name, serial (software key, shows on the DVD cover) and site code.

Step 3 Click on the "Generate Activation Code" button, and your activation code will be shown in the Activation Code field.

Activate "Sure Cuts A Lot"

Important: You only need to do the following if you are having trouble activating from within "Sure Cuts A Lot" or do not have an Internet connection on the computer you are trying to activate on.

You must activate in order to use the full version of the software. Generally, you will just need to choose Activate.. from the Help menu in Sure Cuts A Lot and enter your name and serial number. The software will try to activate automatically and you can disregard this web page. **Do not** use this web page if you have not installed the software yet or have not purchased.

If you view the About box in Sure Cuts A Lot and it shows your name and serial number, the software is activated ok.

If you have problems activating automatically, you must use this web page and generate an Activation Code. The Name and Serial information is obtained from your purchase confirmation e-mail. The Site Code is obtained by running the program and choosing "Activate.." and checking the "Activate Manually" option.

Name:
Please enter your full name

Serial:
Must enter with the dashes (example: 12345-12345-12345-12345-12345)

Site Code:

After entering in your Name, Serial, and the Site Code, click the Generate Activation Code button to create your Activation Code. Copy and paste the value back into the "Activation" dialog box in the application to activate your copy.

If you experience problems generating your Activation Code, please see our [FAQ](#).

Step 4 Copy and paste the activation code back into the activation dialog box of Sure Cuts A Lot program and hit ok.

2.6.2.3 Re-install Sure Cuts A Lot Software

If you change a new computer, you may need to deactivate your Sure Cuts A Lot software and re-install it on your new device.

Go to “Deactivate...” under Help and press Yes to confirm, then follow the installation procedure and use **the same code** to activate it on another computer.

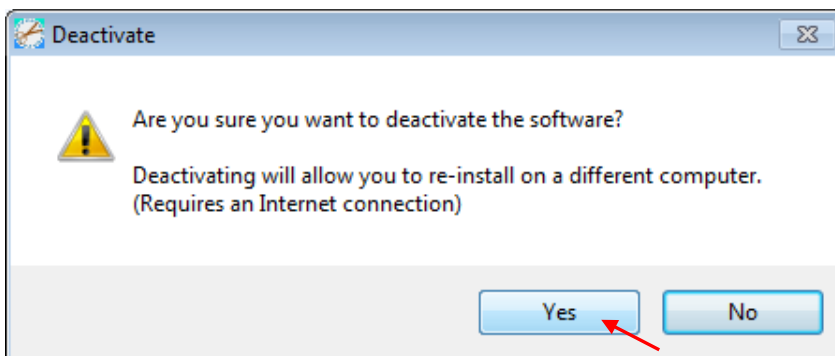
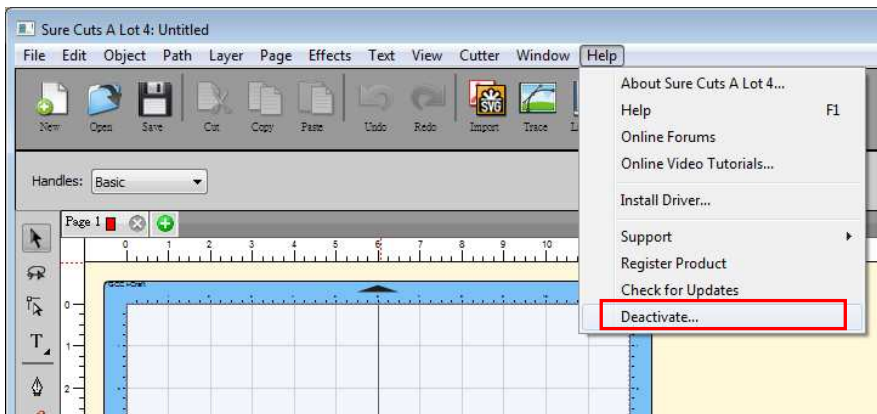

Chapter 3 Operation

3.1 The Control Panel

3.1.1 The Outline of control panel



Figure 3-1

Key	Function
POWER LED	Indicate the power status (LED ON: power on; LED OFF: power off)
ERROR LED	Indicate the error status (LED ON: error; LED OFF: normal)
POWER	Turn the machine on to work.
PAUSE/RESUME	Temporarily halts the cutting process or resumes a paused job.
REPEAT	Repeat last job.
DATA CLEAR	Clear up buffer memory.
CUT TEST	Perform cutting tests on different media.
ORIGIN SET	Reset origin at a new position.
(SIZING)	Press twice to perform Media Sizing (Error LED: blink).
4 Arrow Keys	Moves carriage position.

3.1.2 Reset Origin

Note:

- ✓ The function key to set origin and resize is the same one, press once to activate origin reset while press twice to activate resizing function.

Step 1 Move the carriage to a new position using 4 arrow keys.

Step 2 Press the ORIGIN SET button to reset origin.

3.1.3 Cut Test

Note:

- ✓ It is recommended to run this function until the cutting quality meets your demand before executing the cutting job.

Step 1 After sizing, move the carriage to a preferred position.

Step 2 Press CUT TEST button to begin.

3.1.4 Repeat

Note:

- ✓ Make sure the carriage is at the position you want to cut when performing repeat function.

Step 1 Press the REPEAT button to repeat the cutting function starting at the position where the carriage is located. Otherwise, the carriage can be moved to a preferred position, and after re-setting the position as the new origin, user can use the repeat function to repeat a job.

3.2 VLCD

“VLCD” is a program for modifying parameters of cutting functions.

3.2.1 Installation

Step 1 Copy the VLCD.exe file in the Accessories folder of the AR-24 Installation CD onto your local drive.

Step 2 Launch VLCD by double-click on the icon.

Note:

- ✓ Make sure the machine is power-on to enable this program.
- ✓ The media is loaded on the machine.

Step 3 Choose the correct port setting that is used for connecting the cutter to your computer (Figure 3-2).

If you are using the USB cable, choose the **model name** from the pull down menu. If you are using a Serial cable, choose either **COM1** or **COM2**. Make sure no other devices are occupying the port that you are going to use.

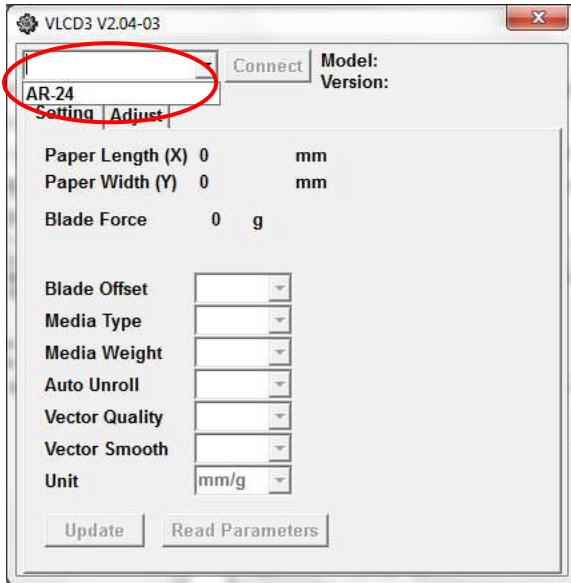

Figure 3-2

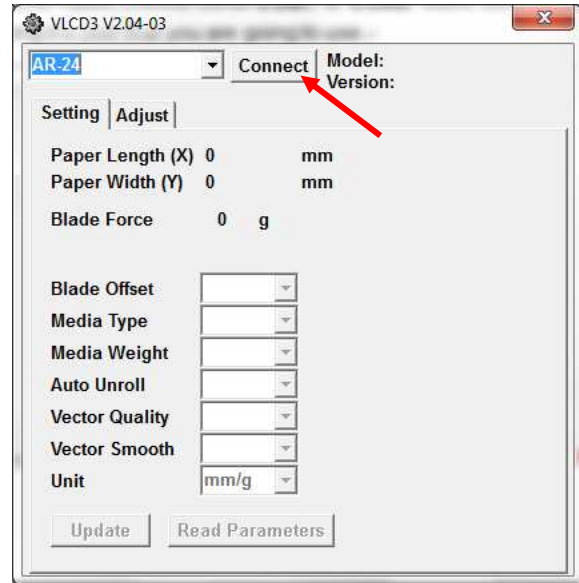

Figure 3-3

Step 4 Press the **Connect** button to connect your computer and the cutter.

If the connection succeeds, the model info, firmware version, and adjustable parameter columns will be shown (Figure 3-3).

3.2.2 Functions of VLCD

Below are the functions adjustable through the VLCD for AR-24.

- Poll Size
- Blade Force
- Blade Holder
- Media Weight
- Blade Offset
- Auto Unroll
- Update
- Vector Smooth

■ **Poll Size**

Click on the **Poll Size** button to reveal the X/Y values.

Paper length represents the maximum plotting length. Paper Width represents the distance between the farthest two pinch rollers. (Figure 3-4).

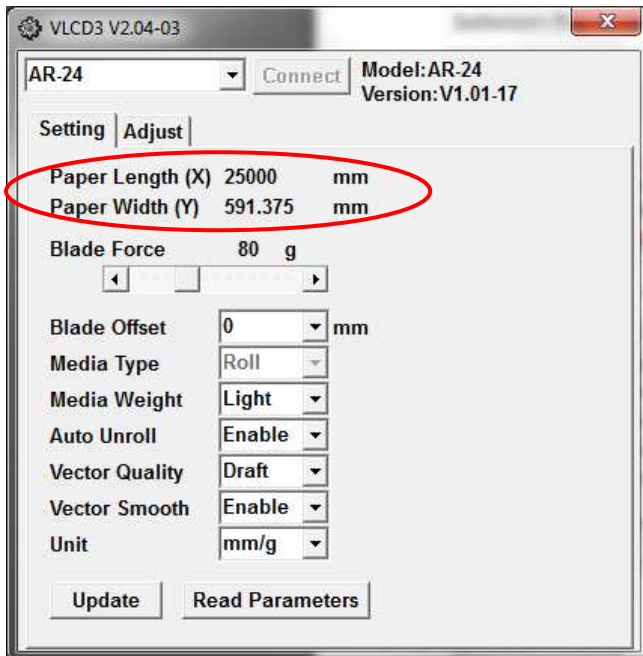

Figure 3-4

■ **Blade Force**

Adjust the blade force between 0 and 250 g (Default = 80).

■ **Media Weight**

Allow user to select the media weight. There are 2 options: Heavy, and Light (Default).

■ **Blade Offset**

Adjust the blade offset to ensure cutting quality. There are 8 options: 0.000, 0.175, 0.250 (Default), 0.275, 0.300, 0.500, 0.750, and 1.000.

■ **Auto Unroll**

Allow user to specify whether the cutter is used in single sheet mode (Auto Unroll Off: Default) or in roll media mode (Auto Unroll On).

■ **Update**

Apply the changed setting onto the cutter by press the **Update** button.

■ **Vector Smooth**

Render a smoother curve when outputting arcs. (Default: Disable)

3.3 File Uploader

3.3.1 Installation

- ✓ “File Uploader” is a tool to help loading files for direct output.
- ✓ The program **ONLY** supports HPGL format-files generated via GCC Cutter driver.
- ✓ Copy the GCC File Uploader.exe file in the Accessories folder of the AR-24’s Installation CD onto your local drive to finish installation.
- ✓ Launch GCC File Uploader by double-click on the icon (Figure 3-5).

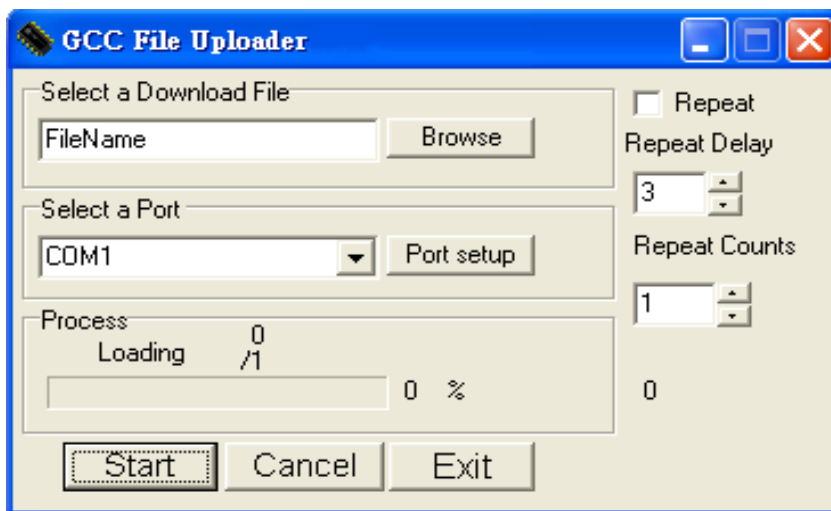

Figure 3-5

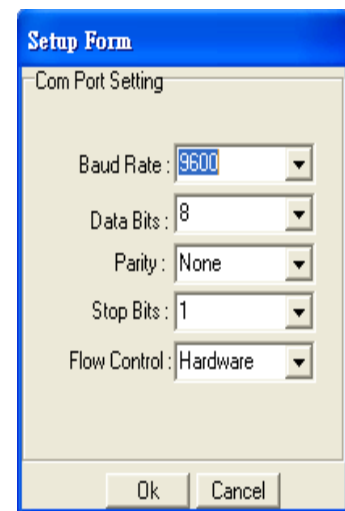

Figure 3-6

3.3.2 Functions of File Uploader

- **Port setup**
 - ✓ This function will be activated while choosing COM port for data transmission.
 - ✓ Press the Port setup button to pop up the setup window for parameter change (Figure 3-6).
- **Repeat**
 - ✓ Activate this function by click on the Repeat’s checkbox.
 - ✓ Repeat Delay – the pause time between jobs; Unit: second.
 - ✓ Repeat Counts – the number of repeat jobs.

3.4 Data Transmission

There are two options to transmit the data from the computer to the cutting plotter:

Option 1: With proper interface settings, the data can be transmitted from your application software package to the cutting plotters directly.

Option 2: Most cutting software packages are able to emulate **HP-GL** or **HP-GL/2** commands,

therefore. As long as the file is **HP-GL** or **HP-GL/2** format, the cutting plotter can output the data precisely.

3.5 AR-24 Print Driver setting

3.5.1 AR-24 Print Driver setting>Option Page

File Function:

The file function section allows users to set the parameters of Speed, Force, Offset and Quality for later use. This section is useful when performing repeated jobs on a variety of objects, allowing you to save your frequently used cutter parameters and load them in the future.

- **Custom Media:** This section lists the files for the parameter settings that you have recently created and worked. You can save more than 50 files to simplify your cutting job.
- **Default:** This section contains the reference settings that are applicable with the verified materials to achieve the best cutting results. Please note that the setting value might need to be adjusted according to different suppliers of materials.
- **SAVE:** This function will save current print driver parameter settings to a file under the specified location on your computer. (Saved parameter setting files will be tagged with the AR-24 series extension)
- **LOAD:** This function allows you to load previously saved print driver parameters.
- **ORIGINAL:** This function will load the print driver's original factory parameter settings.
- **SAVE TO DEFAULT:** This function allows you to save your current print driver parameters as the default startup settings.
- **DELETE:** This function will delete the file you select from the Custom Media section, whereas the settings in Default section cannot be deleted. Please note the delete function only removes the list shown in Custom Media section, it does not remove the file from your hard drive, if you wish to completely remove the file from your hard disk, you will have to manually delete the file from your operating system.

Die Cut

The Die Cut function must be activated with the Kiss Cut function to avoid the falling of cut-through materials and material jam beneath the carriage. Die Cut helps you to cut through the backing of the material while Kiss Cut cuts through only the top layer but not the backing. This will leave only tiny bits of the backing attached to the top layer, creating complete individual patterns with backing sheets (see figure 3.7 and 3.8).

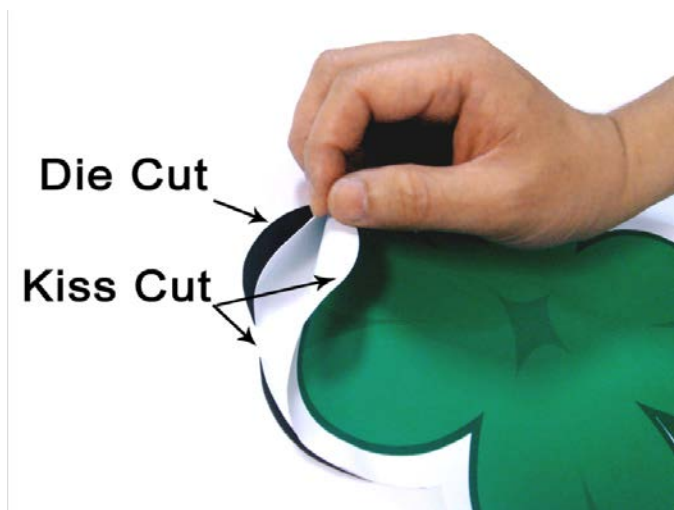
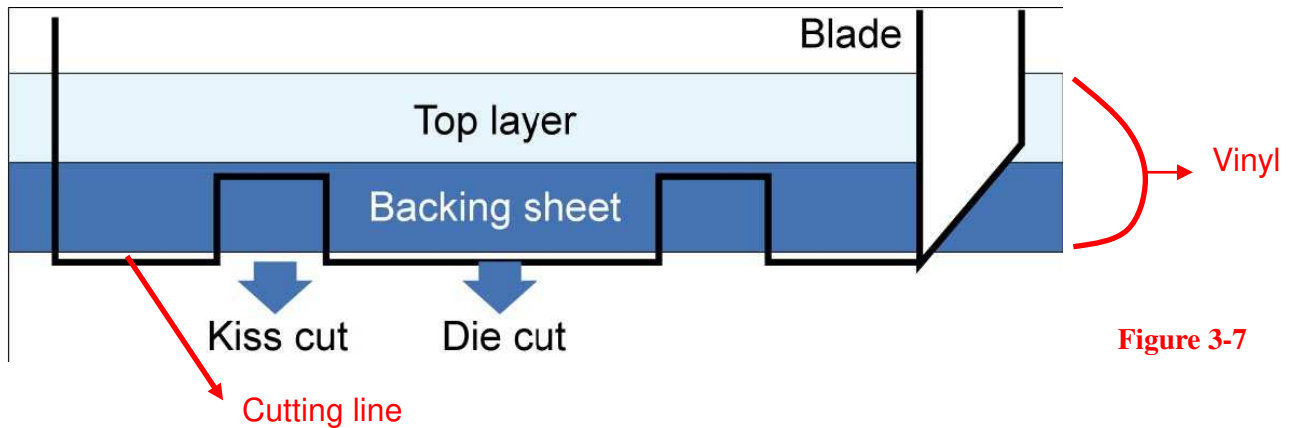

To activate the Die Cut function, go to "Option", tick "Die Cut", and enter the amount you wish for the "Length" and "Force" of both Die Cut and Kiss Cut, then click "OK" (see figure 3.9).

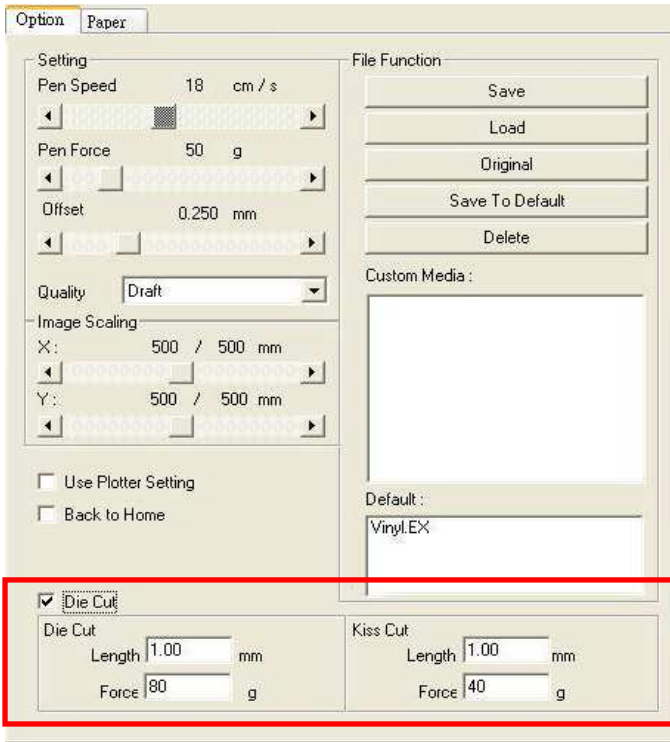
**Note:**

The length setting for the cutting line of Die Cut is in the range of 0-2000mm whereas that of Kiss Cut is 0-100mm.

Figure 3-9

When the job is completed and you untick the Die Cut function, you will be able to adjust the pen speed, pen force, and offset in the section on the top following normal operating procedures (see figure 3.10).

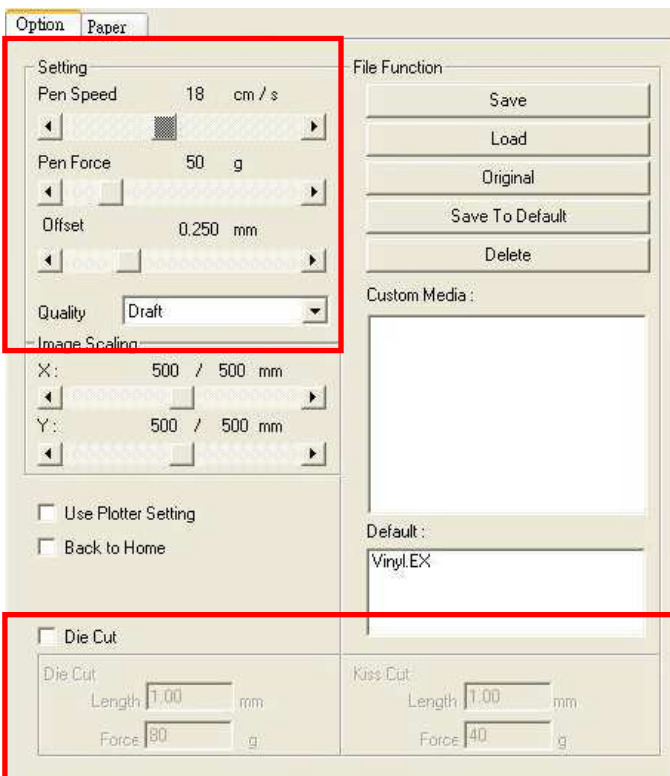
**Note:**

1. The extension of the blade has to be set to cut through both the top layer and the backing in the very beginning. You then adjust the tool force for the best cutting performance.
2. Once the Die Cut function is activated, it will perform on all the line segments on the object.

Figure 3-10

3.6 Reference Parameter setting for different materials

The following reference parameter is used on GCC verified materials shown in the table.

Material	Personalized/ Wall stickers	Vehicle stickers	Window decoration	Window tint
Blade	red	red	red	red / yellow
Blade tip length (mm)	0.28	0.27	0.25	0.09
Force (g)	105	85	95	70
Speed (cm/sec)	72	60	65	72
Offset (mm)	0.25	0.25	0.25	0.25
Recommend model	RX, Jaguar, Puma, EX, AR	RX, Jaguar, Puma, EX, AR	RX, Jaguar, Puma, EX, AR	RX, Jaguar, Puma, EX, AR
Material	Stencil	Reflective film	Flock	Cardboard
Blade	red / green	green	green	green
Blade tip length (mm)	0.3	0.5	0.3	0.3
Force (g)	180	380	135	165
Speed (cm/sec)	15	3	30	30
Offset (mm)	0.25 / 0.5	0.5	0.5	0.5
Recommend model	RX, Jaguar, Puma, EX, AR	RX, Jaguar, Puma, EX	RX, Jaguar, Puma, EX, AR	RX, Jaguar, Puma, EX, AR
Material	Magnets	Protective tint	Rhinestone	Sandblast mask
Blade	green	green	green	blue
Blade tip length (mm)	0.8	0.3	0.8	0.27
Force (g)	580	320	190	85
Speed (cm/sec)	3	3	15	60
Offset (mm)	0.5	0.5	0.5	0.25
Recommend model	RX, Jaguar	RX, Jaguar, Puma, EX	RX, Jaguar, Puma	RX, Jaguar, Puma, EX, AR
Material	Small text (vinyl)			
Blade	black			
Blade tip length (mm)	0.27			
Force (g)	thick: 150 thin: 90			
Speed (cm/sec)	9			
Offset (mm)	0.175			
Recommend model	RX, Jaguar, Puma			

Chapter 4 Basic Maintenance

This chapter explains the basic maintenance (i.e. cleaning the cutting plotter) required for the cutting plotter. AR-24 for the steps mentioned below, all the other maintenances must be performed by a qualified service technician.

4.1 Cleaning the cutting plotter

In order to keep the cutting plotter under good conditions and have the best performance, you need to clean the machine properly and regularly.

[Precaution in Cleaning](#)



- ✧ **Unplug the cutting plotter before cleaning.**
- ✧ **Never use solvents, abrasive cleaners or strong detergents for cleaning. They may damage the surface of the cutting plotter and the moving parts.**

[Recommended Methods](#)

- ❖ Gently wipe the cutting plotter surface with a lint-free cloth. If necessary, clean it with a water-rinsed or an alcohol-rinsed cloth. Wipe the cutting plotter to remove any residues on the cutting plotter. Finally absorb water with a soft, lint-free cloth.
- ❖ Wipe all the dust and dirt from the tool carriage rail.
- ❖ Use a vacuum cleaner to clean any accumulated dirt and media residue beneath the pinch roller housing.
- ❖ Clean the platen, paper sensors and the pinch rollers with a water-rinsed cloth or alcohol-rinsed cloth. Finally absorb water with a soft, lint-free cloth.
- ❖ Use the same method mentioned above to clean dust and dirt from the stand.

4.2 Cleaning the Grid Drum

- ❖ Turn off the cutting plotter, and move the tool carriage away from the area needed to be cleaned.
- ❖ Raise the pinch rollers and move them away from the grid drum for cleaning.
- ❖ Use a bristle (a toothbrush is also acceptable) to remove dust from the drum surface. It needs to rotate the drum manually to clean the drum completely (Figure 4-1).

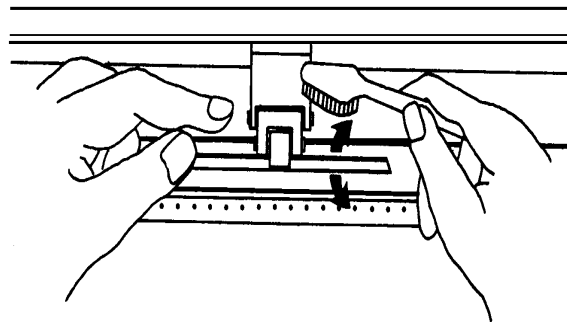

Figure 4-1

4.3 Cleaning the Pinch Rollers

If the pinch rollers need a thorough cleaning, use a lint-free cloth or cotton swab to wipe away the accumulated dust from the rubber portion of the pinch rollers. To prevent the pinch rollers from rotating while cleaning, use your fingers to hold the pinch rollers in place.

Use a lint-free cloth or cotton swab rinsed with alcohol to remove the embedded or persistent dust.

Chapter 5 Troubleshooting

This chapter helps you to correct some common problems you may come across. Prior to getting into the details of this chapter, please be sure that your application environment is compatible with the cutting plotter.

Note:

Before contacting your local dealer, please make sure that the problems are coming from your cutting plotter, not from the communication between the computer and cutting plotter or from a malfunction in your computer or software.



Why doesn't the cutting plotter operate?

5.1 What if AR- 24 cannot operate?

If your cutting plotter doesn't plot, please check the following items first:

Is the power cord plugged in properly?

Is the power cord connected to the power connector properly?

Is the power switch turned on properly?

Solutions: If the POWER LED lights on, the cutting plotter should be in a normal condition.

Turn off the cutting plotter and turn it on again to see if the problem still exists.

If the POWER LED doesn't light, please call your local dealer to resolve this problem.

5.2 Cutting Quality Problems

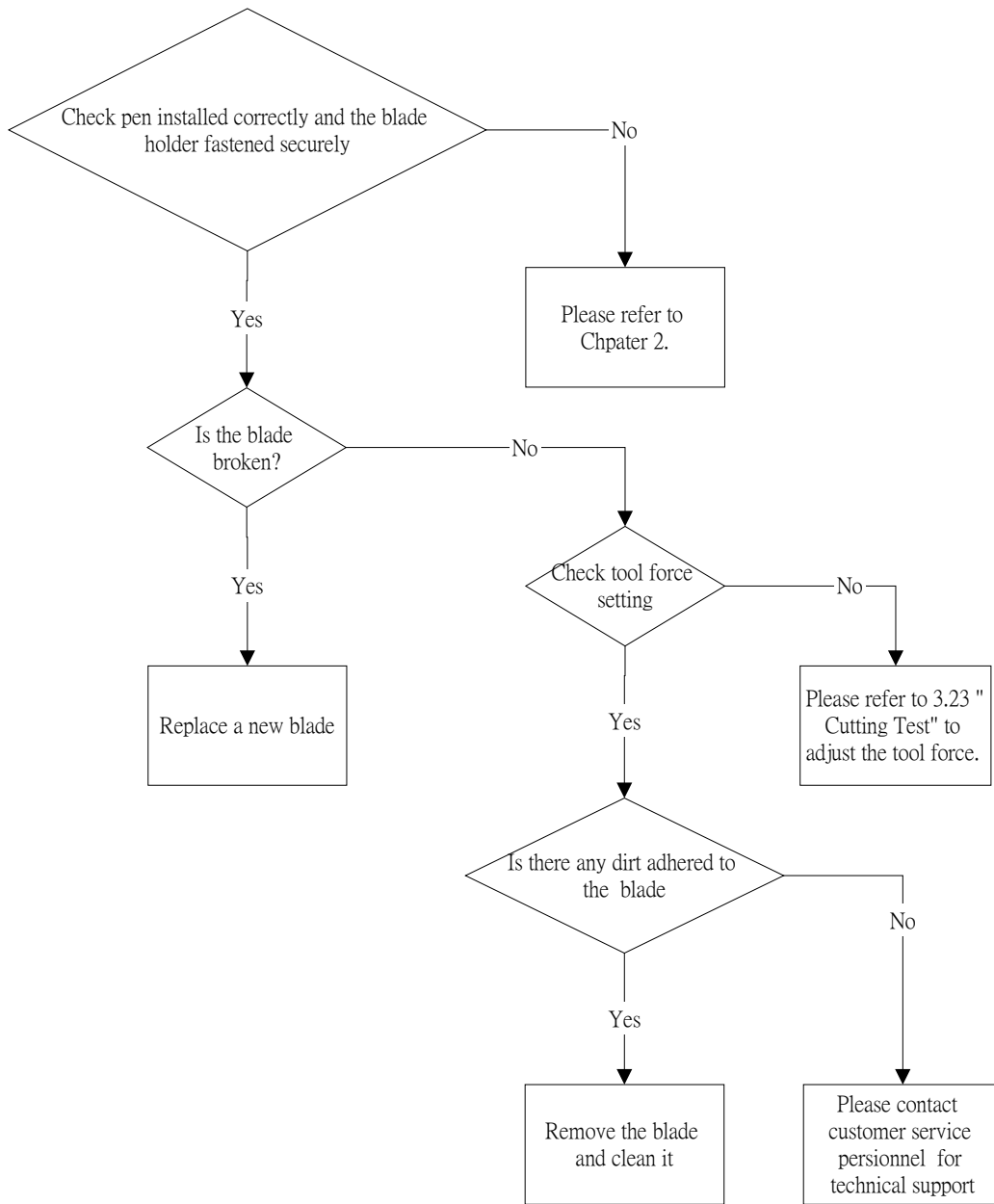





AR-24 Specification

Model	AR-24	
Operational Method	Roller-Type	
Max. Cutting Width	600mm (23.6")	
Max. Cutting Length	50m (164')	
Max. Media Loading Width	719mm (28.3")	
Number of Pinch Rollers	3	
Material Thickness	0.8mm (0.03")	
Drive Motor	Stepper motor	
Max. Cutting Force	250g	
Max. Cutting Speed	552 mm /sec (21.7 ips) (at 45° direction)	
Acceleration	0.7 G (gravity)	
Offset	0~1.0 mm (with an increase of 0.025mm)	
Memory Buffer	1 MB	
Interfaces	USB 2.0 (Full Speed), Serial (RS-232C)	
Type of Command	HP-GL, HP-GL/2	
Mechanical Resolution	0.012 mm	
Software Resolution	0.025 mm	
Distance Accuracy	±0.254 mm or ±0.1% of move, whichever is greater	
Repeatability	±0.1mm	
Curve & Arc Smoothing	Yes	
Configurable Origin	Yes	
Test Cut capability	Yes	
Repeat	Yes	
Control Panel	2 LEDs/10 Keys	
Diameter of Blade	2.5 mm	
Power Supply	AC 100-240V, 50~60 Hz (auto switching)	
Power Consumption	40 watts	
Stand	Standard	
Operation Environment	Temperature	15°C~30°C / 60°F~86°F
	Humidity	25% ~ 75%

- Compatible with Windows 7 and above & MAC OS X 10.6 and above. (*Purchasing serial number for “Sure Cuts A Lot” software to work with Mac OS.)
- The specification and data sheet may vary with different materials used. In order to obtain the best output quality, please maintain the machine regularly and properly.
- GCC reserves the right to change the specifications at any time without notice.
- GCC certified material in tracking is Avery MPI 3000.
- The above listed specification values are effective only when operated with media certified by GCC.

Blade Specification

202003480G	For cutting thick fluorescent and reflective vinyl. Also for cutting detailed work in standard vinyl.
	The blade is 45° with Red Cap (5-unit package), 0.25 mm offset, and 2.5 mm blade diameter.
	
290088080G	For cutting reflective vinyl, cardboard, sandblast, flock, and stencil sharp edge.
	The blade is 60° with Green Cap (2-unit package), 0.50 mm blade offset, and 2.5 mm blade diameter.
	
265017550G	For cutting thin sandblast mask and stencil. The blade with sharp angle and special design, allowing it to maneuver around sharp corners.
	The blade is 60° with Blue Cap , 0.25 mm blade offset, and 2.5 mm blade diameter.
	
265017560G	For Cutting small text and fine detail. Sharp blade with smallest offset.
	The blade is 50° with Black Cap , 0.175 mm blade offset, and 2.5 mm blade diameter.
	
265017530G	For thin and delicate media such as window tint.
	The blade is 25° with Yellow Cap , 0.25 mm blade offset, and 2.5 mm blade diameter.
	

About the Tool

A generic term referring to the blade that cuts the sheet, the pen that does plotting, and the LED bombsight (option) used for pointing to the reference point.

OFFSET is the distance that the blade tip is displaced from the centerline of the blade.

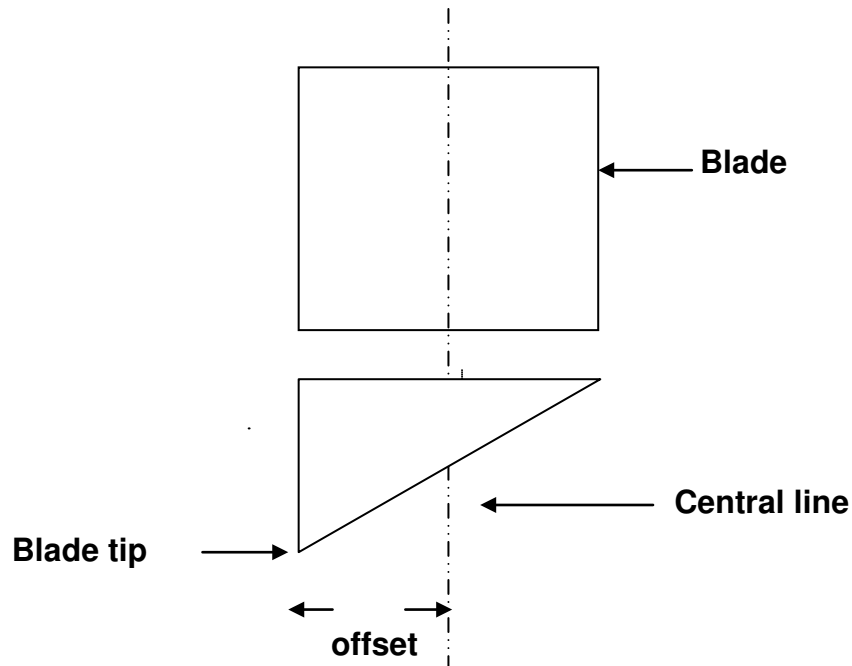

Protrusion Length of the Blade

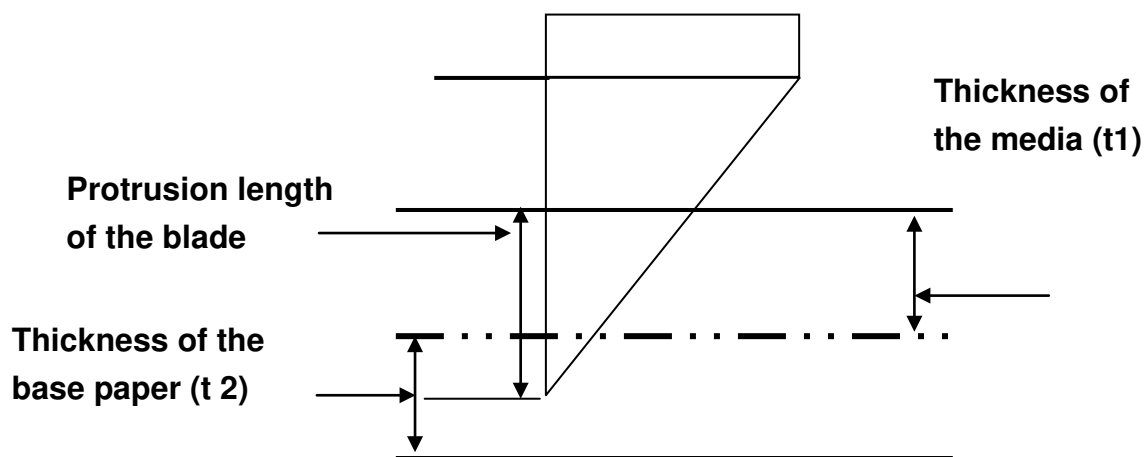

Length of protrusion = $t_1 + t_2 / 2$, but for your convenience you may just make it about 0.3mm ~ 0.5mm beyond the blade holder tip.

CoreIDRAW Output Instruction

The following is an example of how to output the file with CoreIDRAW.

User Instructions

1. Open CoreIDRAW, finish editing all the files you wish to plot and select all the images at once.
2. Select “Outline Pen” to adjust the outline for cutting.

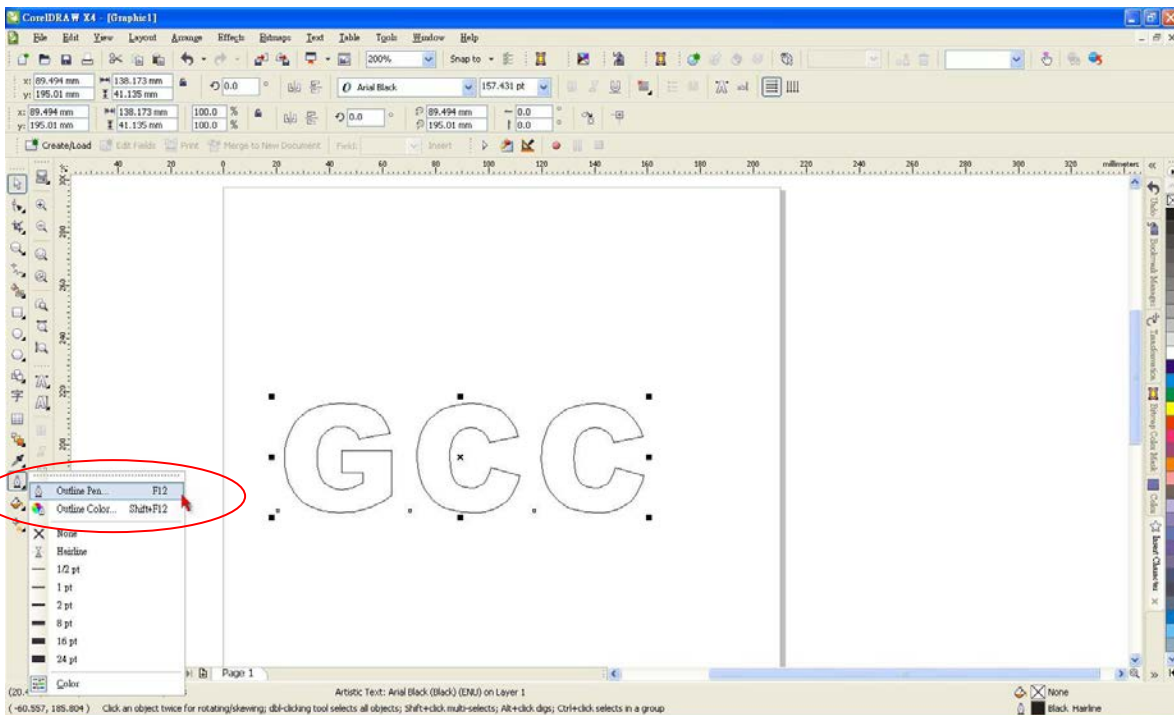

3. Adjust the value of pen width to 0.001 mm and click “OK” to save your input.

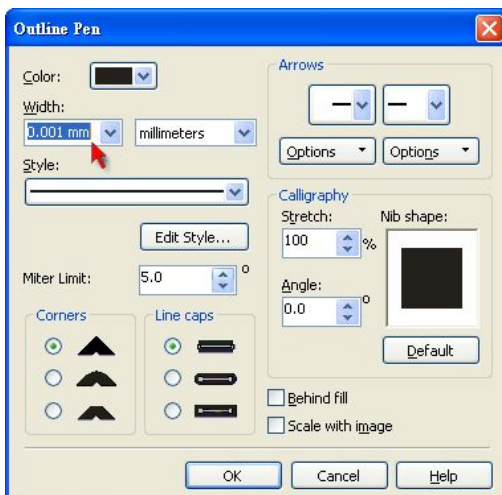

4. Select “ File → Print” to output the file to your cutters.

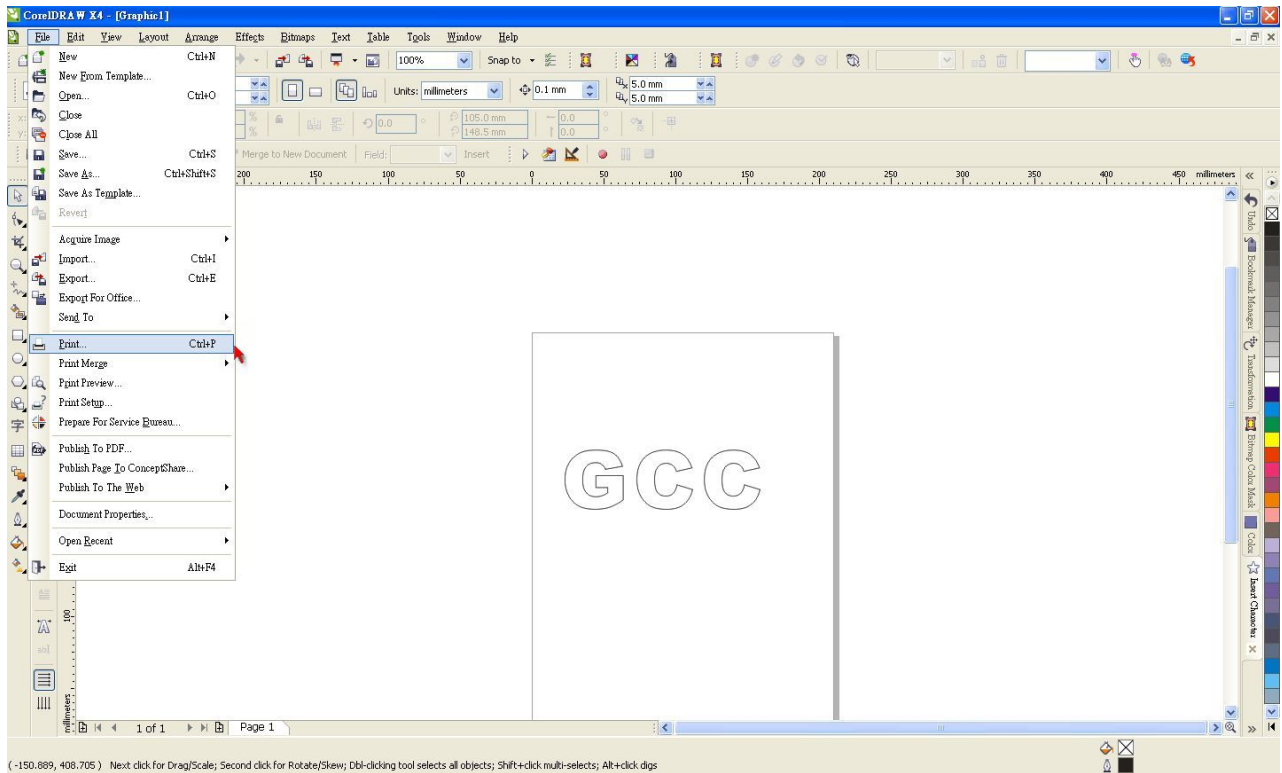

5. Choose the correct model you have installed.

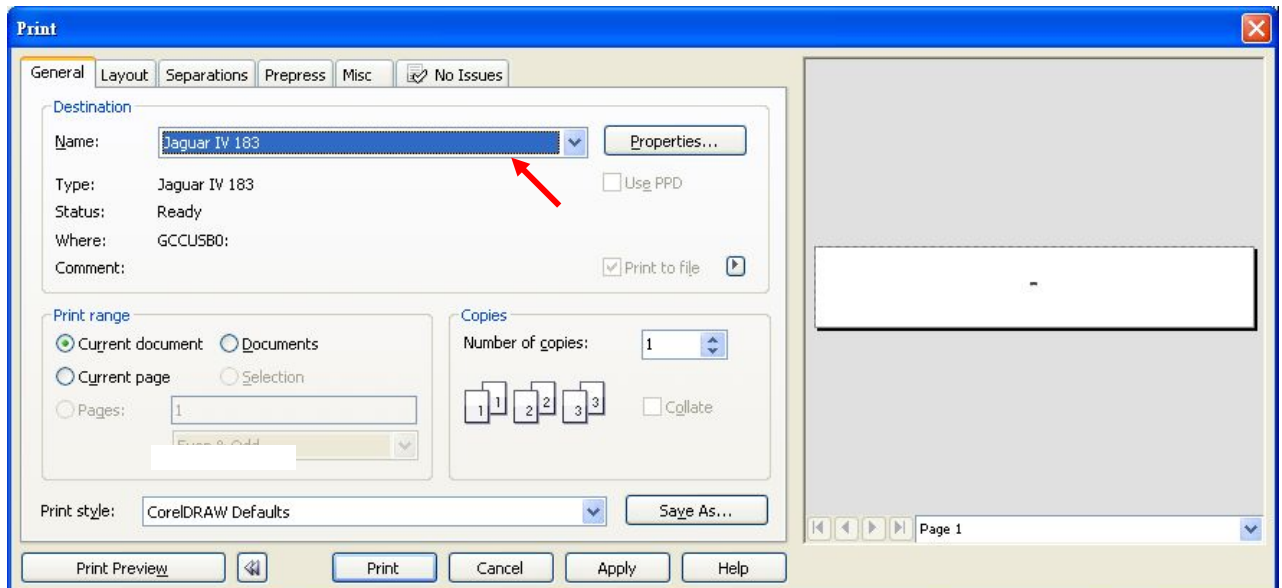

6. Choose the “Layout page” and click the “Reposition images to: → Bottom left corner”.
Please note that you must put your image at the bottom left corner.

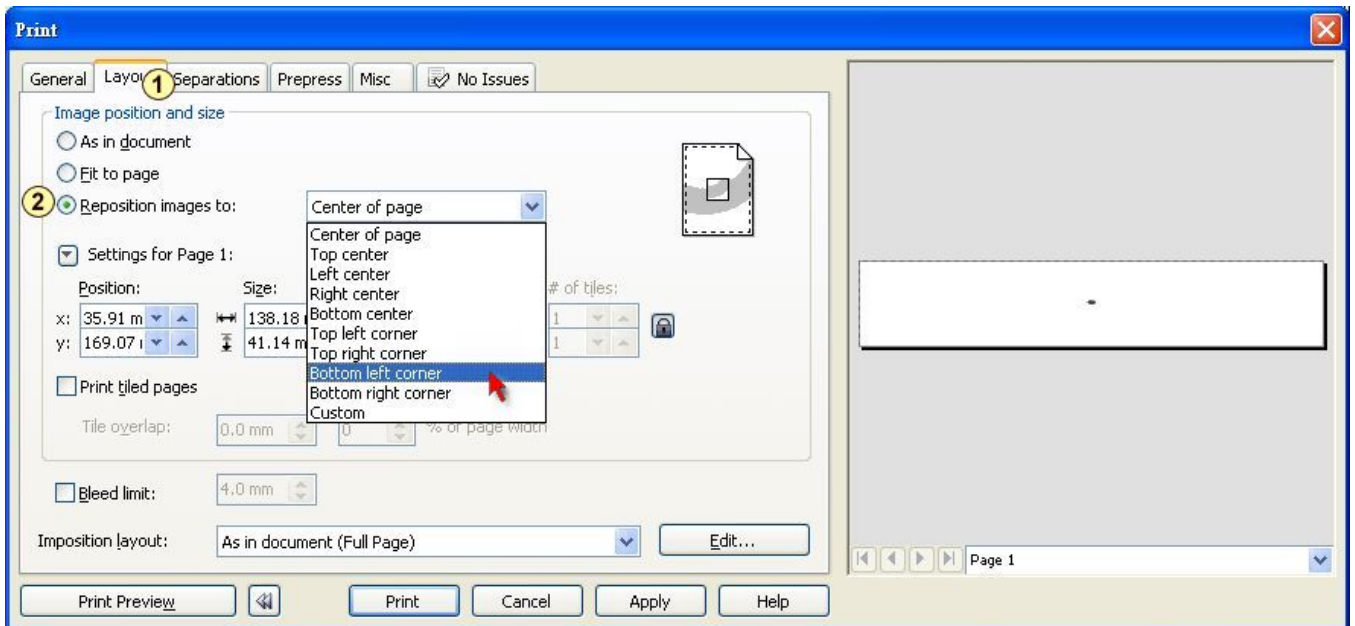

7. Go back to the General page and check that your image is at the bottom left corner. Click “Print” and get a wonderful cutting image.

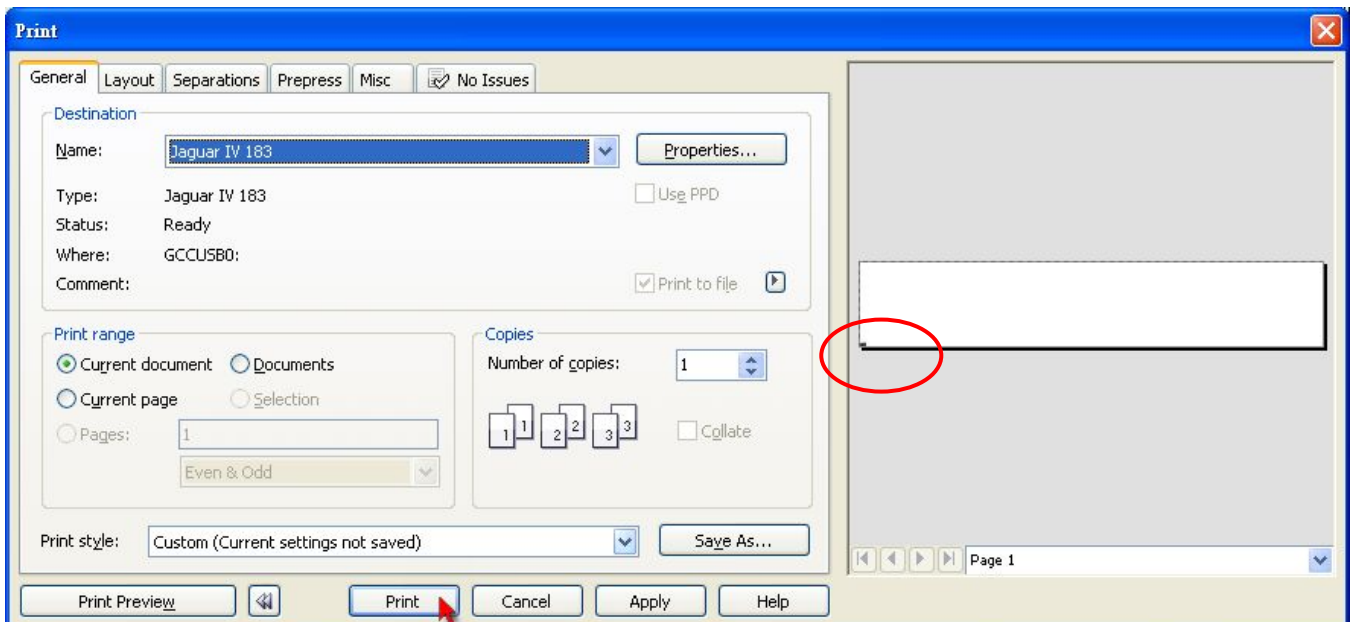

Sure Cuts A Lot

There are basic instructions of Sure Cut A Lot below. If you need detailed instruction, please refer to Sure Cut A Lot Help.

1. Select the cutter you want to output and change the work area.

Step 1 Run Sure Cuts A Lot software.

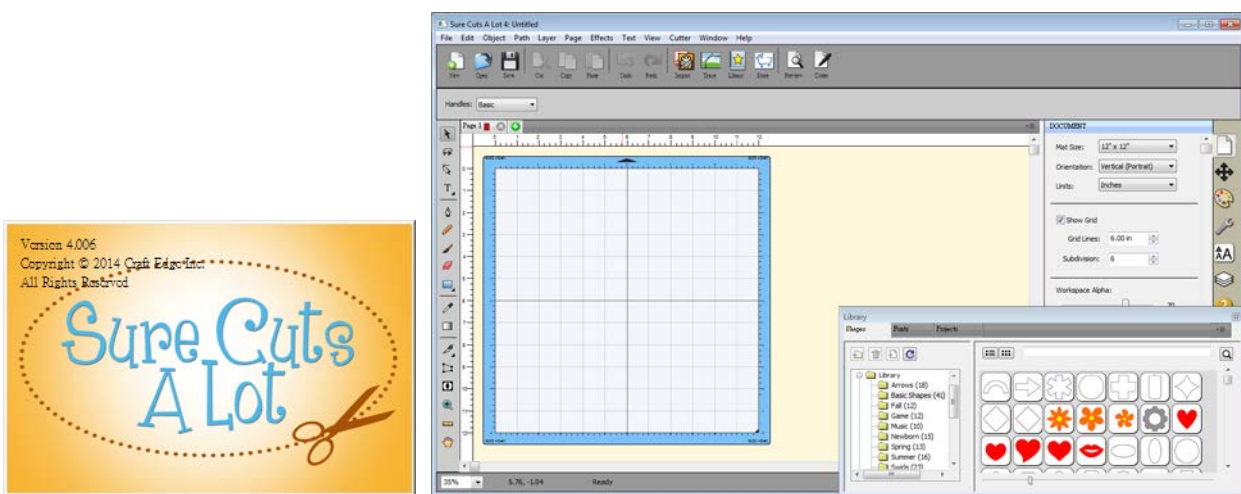

Step 2 Select “Cutter” and select “Manage Cutters” under My Cutter to change the work area.

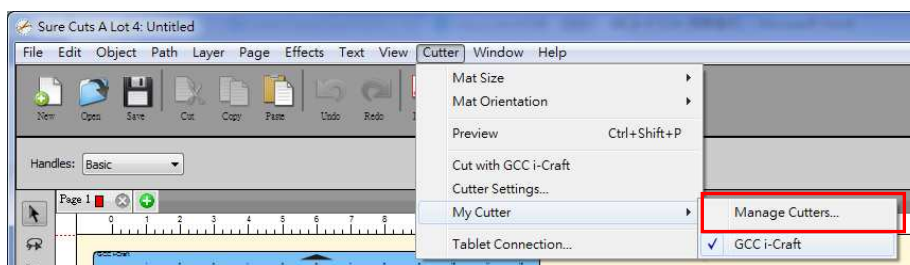

Step 3 Select company / brand as GCC and select model you want to output and then click the “<--Add to list” button.

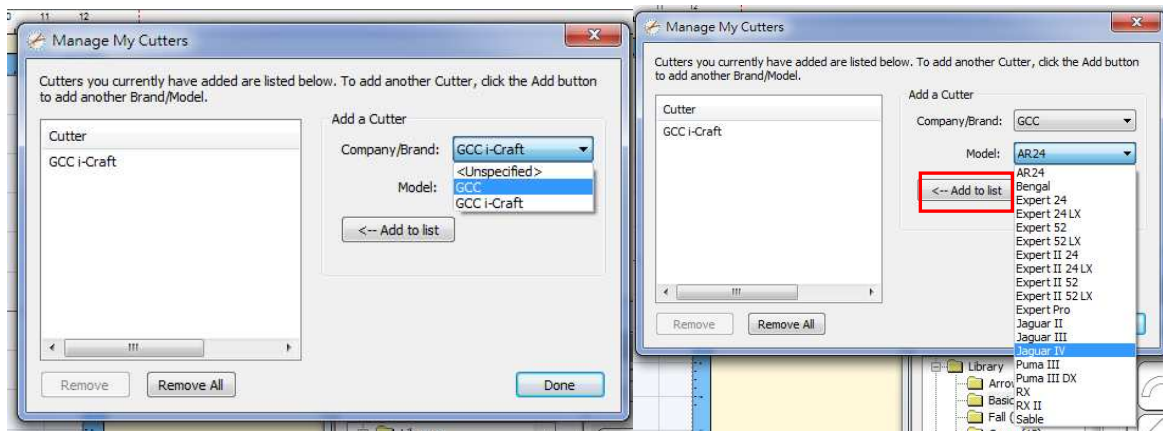

Step 4 Select GCC on the left and click “Done.”

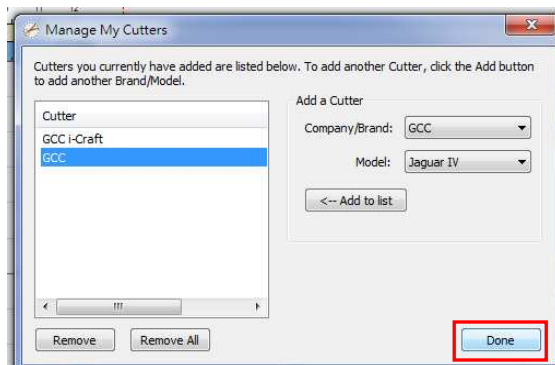

Step 5 If you want to change the material size and orientation, you can fill a proper value in the Document window.



2. Insert Graphics from Library

Step 1 Select graphics from library to insert a selected design.

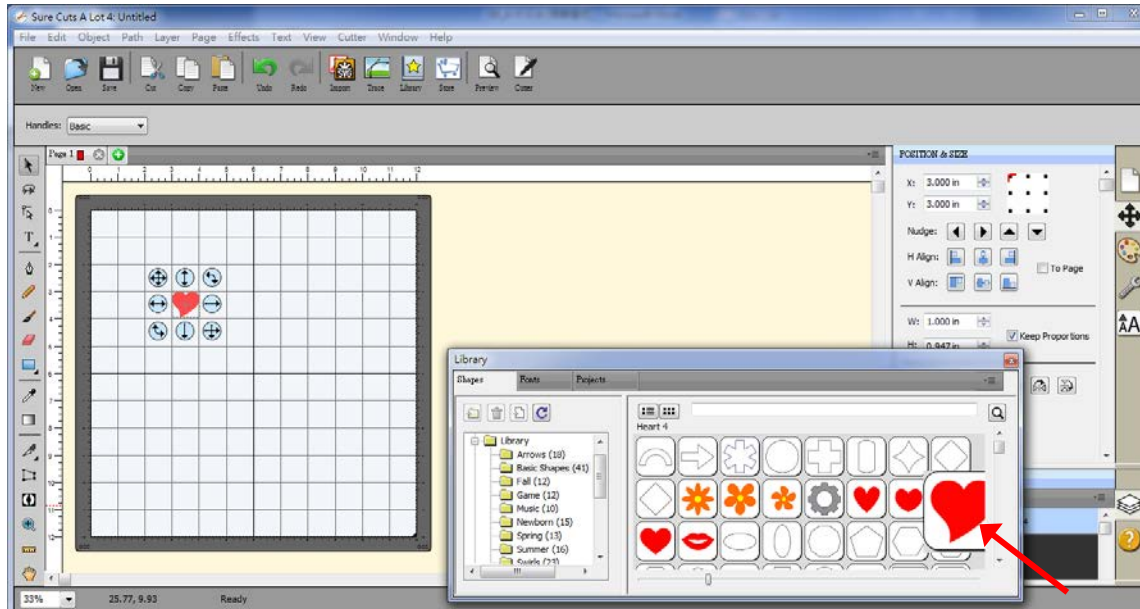

3. Draw Text

Click on the T icon at left side to create the text and select the font you like at text window.

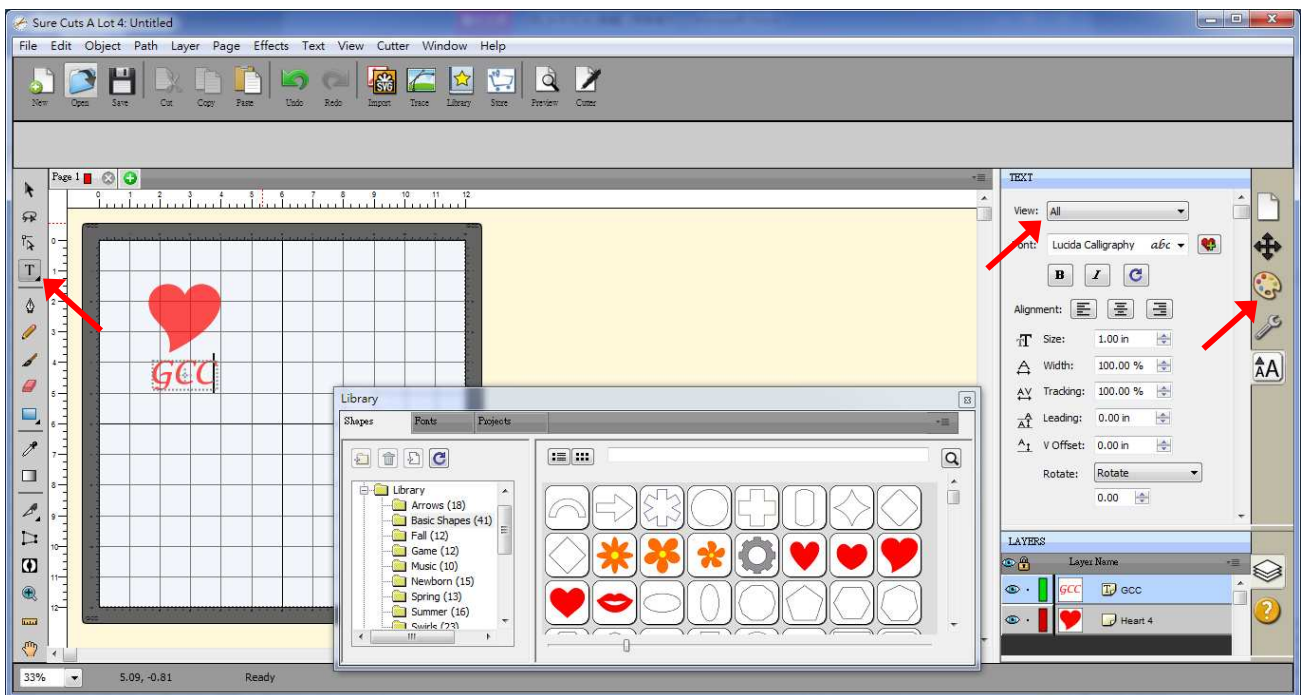

4. Import Design

If you have created your design in other design software, go to “import” or “place image” under file to import it, SCA supports svg, scut, scal, pdf, ai. wpc eps, bmp, gif, jpg and png files.

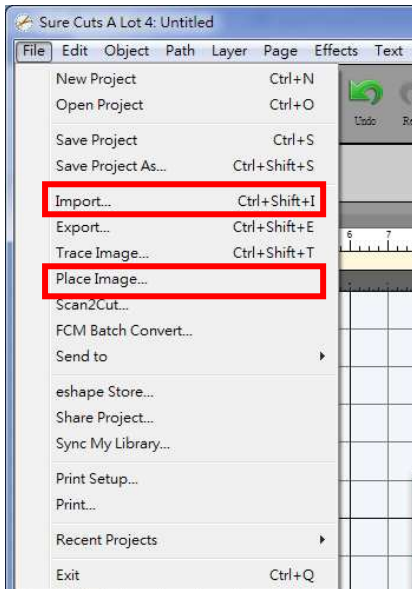

Tips Thousands of SVG files designed specifically for Sure Cuts A Lot!

- ✓ <http://SVGCuts.com> is the top of source for designer SVG files for Sure Cuts A Lot. Thousands of high quality elements including: shapes for card-making, scrapbooking, as well as gift bags, boxes and 3D flowers.

5. Convert Image to Cutting File

Step 1 Go to Trace Image under File, or select Trace Image button on the toolbar to open the setting window.

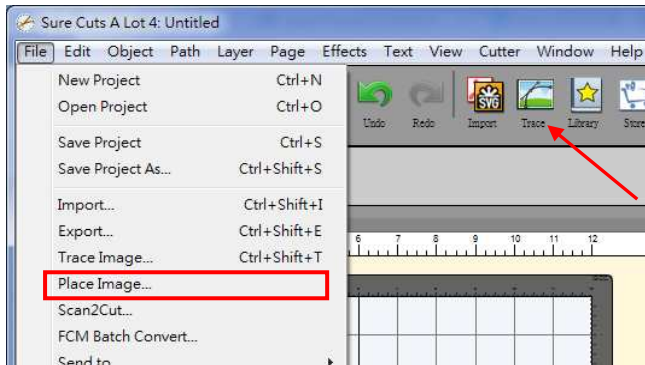

Step 2 Click on “Choose an image” to input the image, adjust Image Settings and Output Settings, and click OK. Then the outline of the image will be outputted automatically.

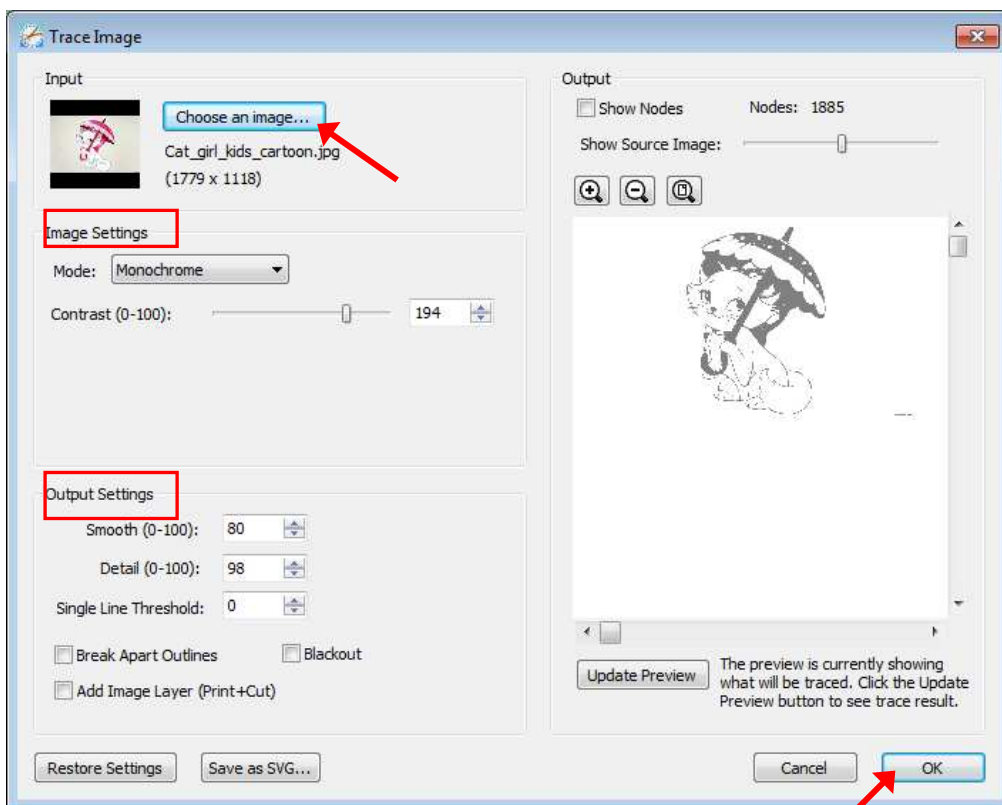

Note

- ✓ The **contrast** and **pixels** of import images will affect the trace image result. High contrast graphics are recommended.

6. Cut the Design

Step 1 Click on the “Cutter” button on the toolbar and Cut Settings window will appear.



Step 2 Click on “Settings...” to open GCC Cutter Settings window.



Note

- ✓ The origin point is on the bottom right.

Step 3 Adjust Registration Marks setting under GCC Cutter Settings window if needed.

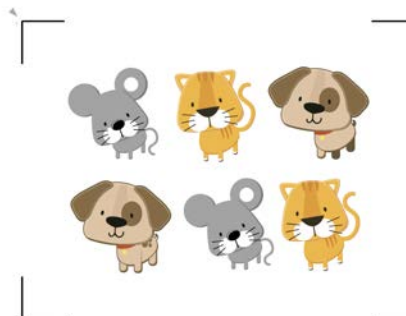
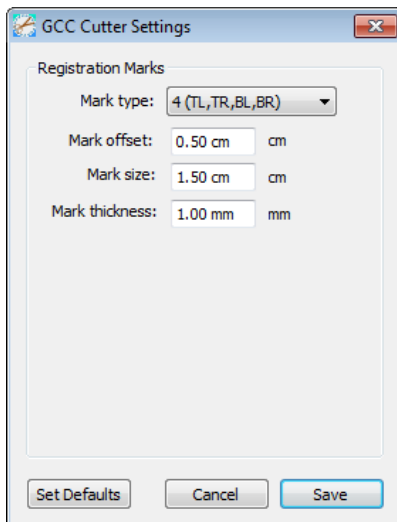

***Registration Marks:** set the distance between the edge of the material and the registration marks in Mark Offset; set the size of marks in Mark Size; set the line thickness of marks in Mark Thickness.

Step 4 Adjust Blade Offset, Overcut Value, Multi-Cut and Quality under Cut Settings window if needed.

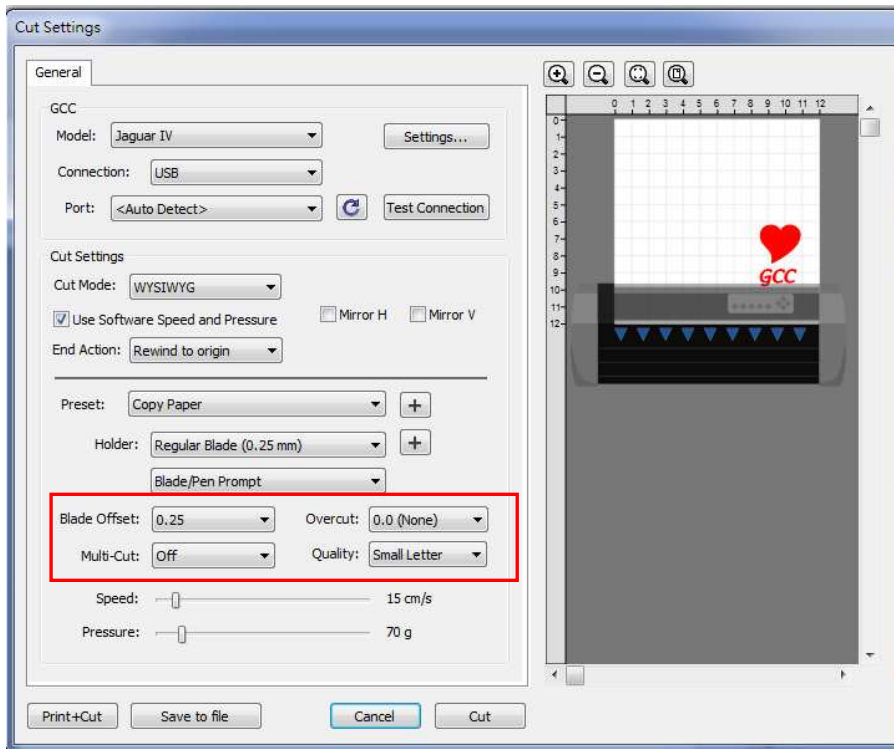

***Blade Offset:** set the offset value according to different blade, for a standard blade, set the offset value at 0.25mm, 0.5mm for an optional advanced blade and 0mm for an optional plotting pen.

***Quality:** associated with the cutting result; please note the better cutting quality, the slower cutting speed.

***Multi-Cut:** to repeat the cutting job at same position which is suitable for cutting thick material.

***Overcut:** allows for easier weeding and makes up for incomplete cut lines.

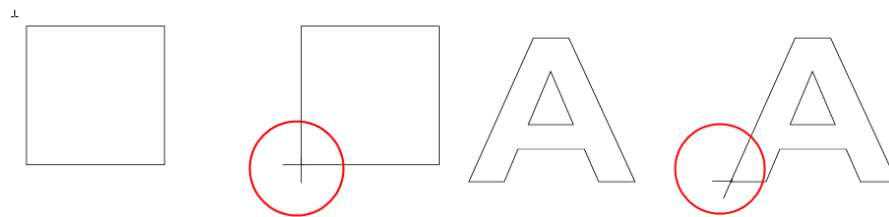

Step 5 Under “Cut Settings” section, there are some useful functions. After setting the parameters, click on “Cut” to send the data to the GCC cutter and the GCC cutter will start the cutting job.

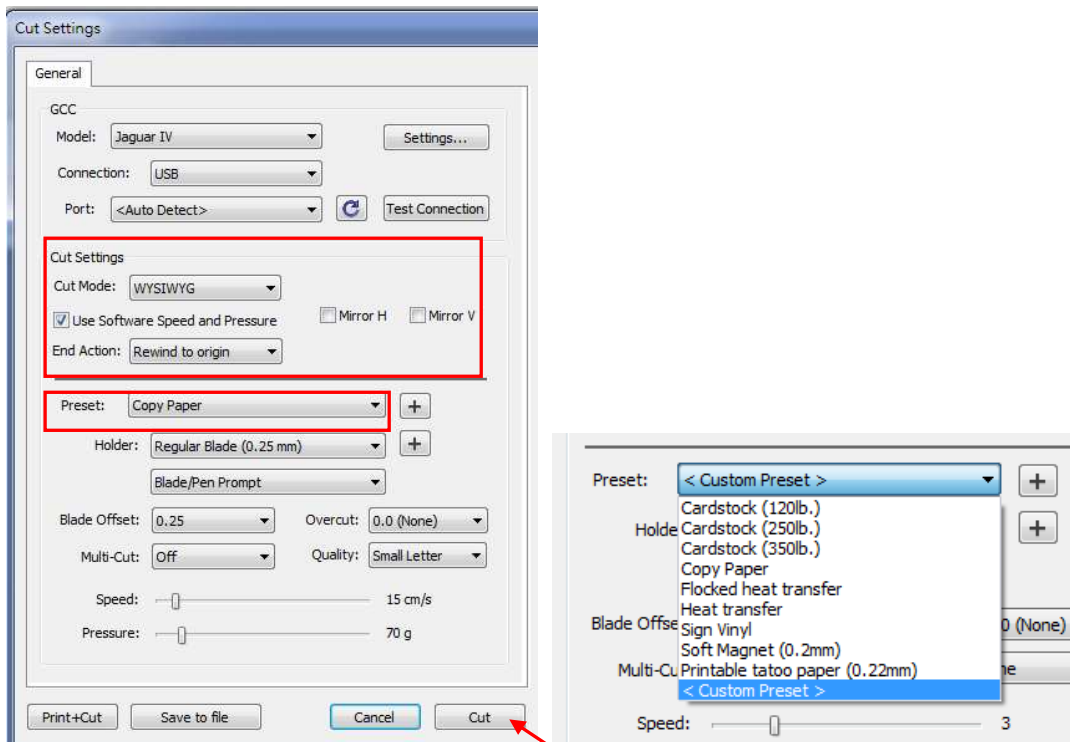

***Cut Mode**: there are “WSIWYG” and “Origin Point” options, WSIWYG means what you see is what you get, the cutter will output the graphic at same position in preview window. While with Origin Point mode, the cutter will cut the graphic from bottom right origin point of the material.

***Use Software Speed and Pressure**: tick this section, and you can set the values of speed and pressure manually.

***Preset**: select a proper material to apply the preset speed and pressure parameter automatically.

***Speed & Pressure**: you may adjust values of speed and pressure manually to get quality results.

7. Print and Cut Your Design

The Print and Cut function allows you to print the graphics from Sure Cuts A Lot to printer, and then put the printed materials on the GCC cutter to cut out the contour of printed jobs from Sure Cuts A Lot.

Step 1 Open an image file in Sure Cuts A Lot.

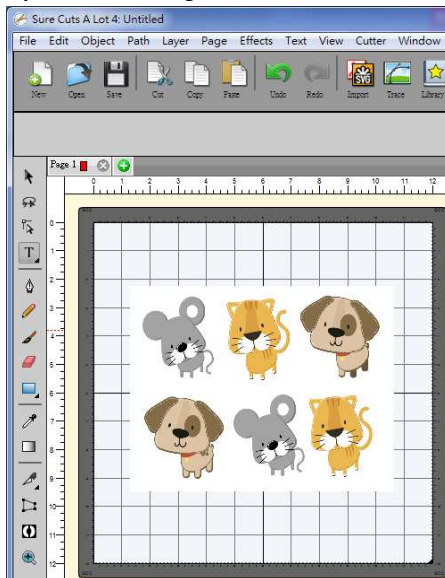

Step 2 Click on the Cutter icon on the toolbar, set the parameters and click on “Print+Cut” to add the registration marks and print out the image.

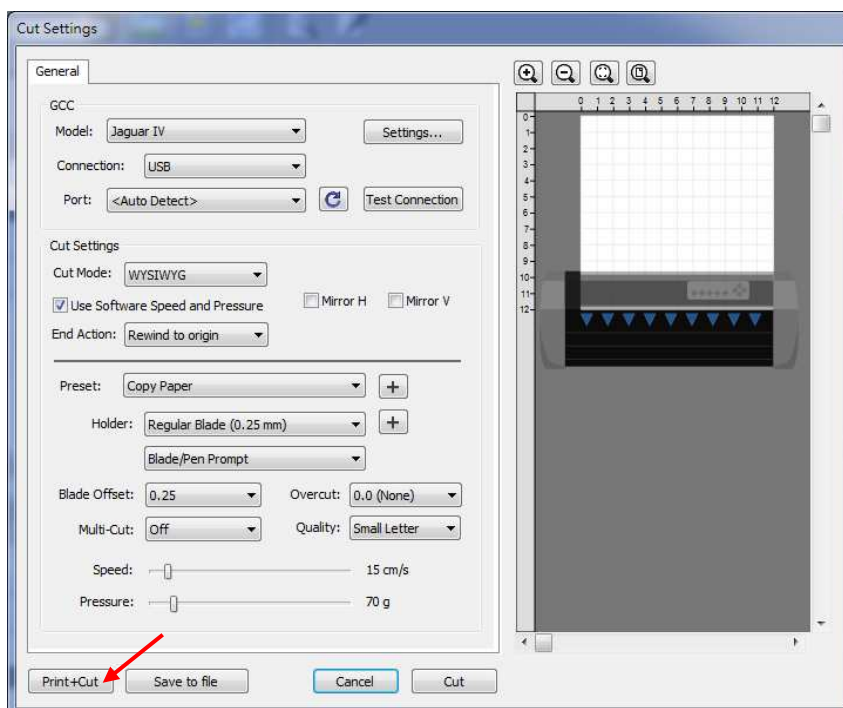

Step 3 Click on “Print...” to open printer setting window and click OK.

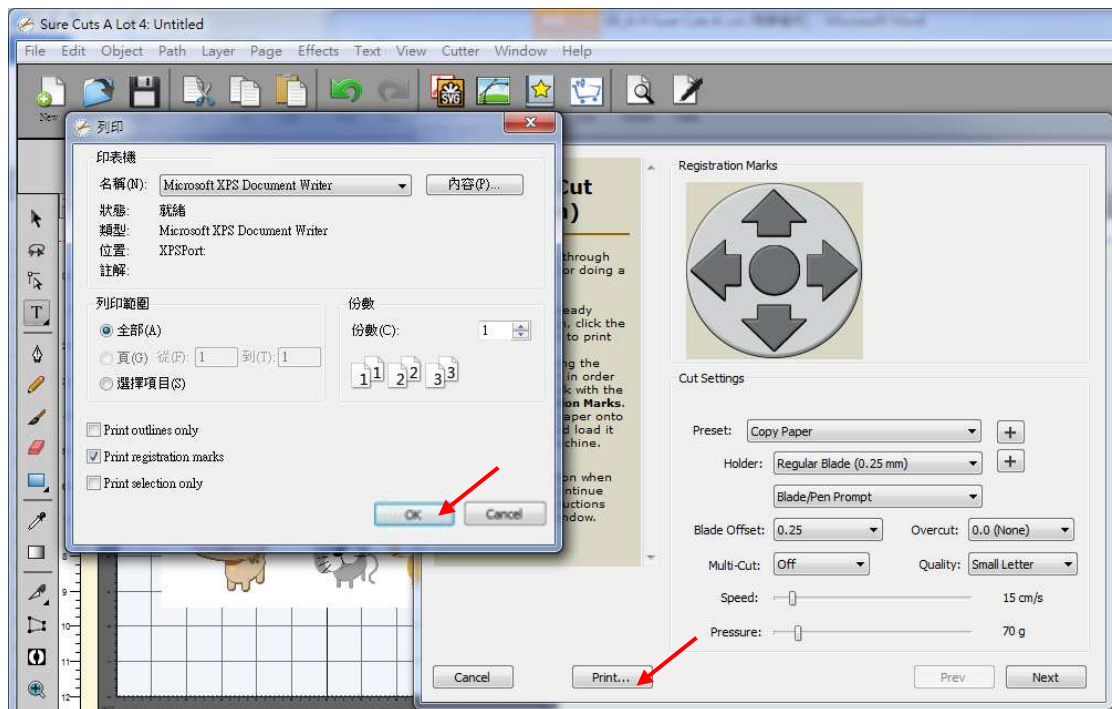

Step 4 Print your design with registration marks out.

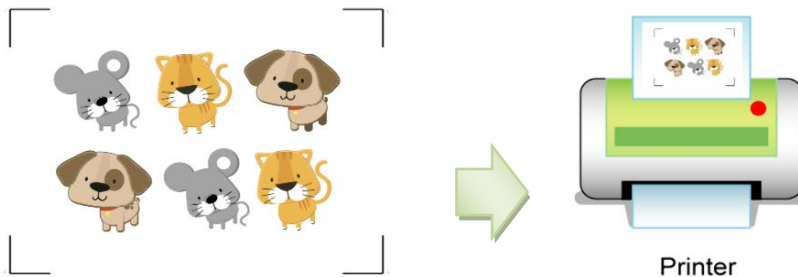

Step 5 Load the printed media to the GCC cutter.

Step 6 Press “Next” and then press “Scan+Cut”, and then the GCC cutter will detect the registration marks and cut the contour lines automatically.

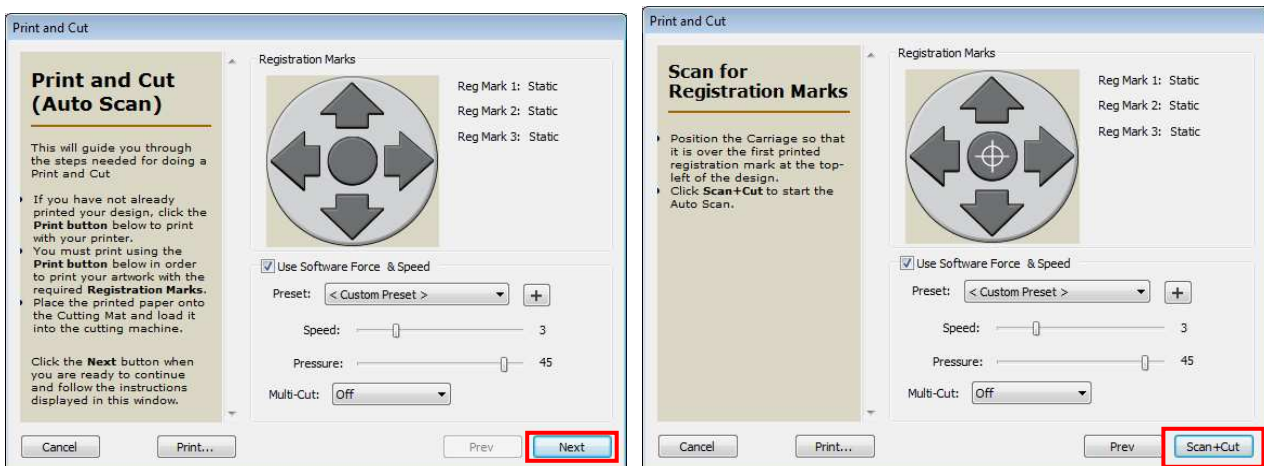

Tips Test Connection function can save your materials.
✓ Click on “Test Connection” to exam if set the connection properly.

